

The logo for BOHS (British Occupational Hygiene Society) features the letters 'BOHS' in a stylized white font on a blue background. The 'O' is a circle with a dot inside, and the 'H' is a simple vertical bar.

British Occupational  
Hygiene Society

The Chartered  
Society for Worker  
Health Protection

# Student Manual: M505

## Control of Hazardous Substances

[www.bohs.org](http://www.bohs.org)

Version 1.0  
February 2024

# TABLE OF CONTENTS

M SERIES COPYRIGHT AND LICENCE INFORMATION.....	i
ACKNOWLEDGEMENTS.....	iii
SYMBOLS & ABBREVIATIONS.....	iv
1. COURSE OVERVIEW .....	1
1.1 Introduction.....	1
1.2 Aim of Course.....	1
1.3 Learning Outcomes .....	1
1.4 Format of Manual .....	2
2. WORKPLACE CONTROL PRINCIPLES .....	4
2.1 Introduction.....	4
2.1.1 Control Challenges .....	10
2.2 Hierarchy of Control.....	11
2.2.1 Prioritisation of Control Methods.....	11
2.2.2 Key Elements of the Hierarchy of Control .....	15
2.2.3 Using a Combination of Controls .....	19
2.2.4 Managing Controls.....	21
3. DESIGNING CONTROL STRATEGIES.....	24
3.1 Introduction.....	24
3.2 A Structured Approach .....	27
3.3 Identifying Sources of Exposure.....	28
3.4 Determining the Degree of Control Required .....	32
3.4.1 Adequate Control.....	32
3.4.2 Occupational Exposure Limits .....	33
3.4.3 Applying Occupational Exposure Limits.....	35
3.4.4 In-house Standards .....	37
3.4.5 Biological Exposure Standards .....	38
3.4.6 Situations Where no Exposure Limits are Available .....	39
3.5 Deciding on Control Options.....	39
3.6 Deciding on Management Measures.....	41
3.7 Control Banding.....	42
4. UNDERSTANDING SOURCES OF CONTAMINANTS.....	51

# TABLE OF CONTENTS

5.	PROCESS DESIGN AND PRINCIPLES .....	58
5.1	General Design of Equipment and Workplace Layout.....	58
5.2	Prevention by Elimination & Substitution .....	61
5.3	Legislation as a Means of Achieving Control.....	70
6.	VENTILATION SYSTEMS .....	72
6.1	Introduction.....	72
6.2	Types of Ventilation Systems .....	72
6.3	Basic Principles of Ventilation .....	74
6.3.1	Definitions .....	74
6.3.2	System Components.....	78
6.4	Local Exhaust Ventilation Systems.....	79
6.4.1	Introduction .....	79
6.4.2	Hood Design .....	80
6.4.3	Ductwork.....	95
6.4.4	Fans.....	98
6.4.5	Air Cleaners .....	103
6.4.6	Discharge to the Atmosphere .....	108
6.4.7	Measurement and Testing of LEV Systems.....	108
6.4.8	Limitations of LEV Systems .....	120
6.5	General Ventilation Systems .....	121
6.5.1	Dilution Ventilation .....	121
6.5.2	Dilution Ventilation Equations .....	122
6.5.3	Infiltration .....	124
6.5.4	Application of General Ventilation Systems .....	125
6.5.5	Displacement Ventilation .....	126
6.5.6	Limitations of General Ventilation Systems.....	127
7.	PRINCIPLES OF CONTAINMENT.....	130
7.1	Introduction.....	130
7.1.1	Definition of Containment.....	130
7.1.2	Use of Containment .....	131
7.1.3	Primary and Secondary Containment .....	131
7.1.4	Integration of Containment With Other Control Measures .....	131

# TABLE OF CONTENTS

7.1.5	Integration of Containment With Process Design .....	132
7.1.6	Typical Industrial Processes Requiring Containment.....	132
7.2	Types of Containment Equipment .....	134
7.2.1	Simple Enclosures and Screens .....	134
7.2.2	Isolators .....	135
7.2.3	Over-bagging .....	136
7.2.4	Transfer Devices.....	136
7.2.5	Coupling Devices.....	137
7.2.6	Remote Handling .....	137
7.3	Design of Containment Systems .....	138
7.3.1	High Level Containment Systems.....	138
7.4	Other Considerations.....	140
7.4.1	Control of Waste and Emissions.....	140
7.4.2	Explosion Prevention and Control.....	141
7.4.3	Operation and Maintenance of Containment Devices.....	142
7.4.4	Limitations of Containment Systems.....	142
7.4.5	Future Developments.....	143
7.5	Testing and Validation of Containment.....	144
7.6	Some Specific Examples of Containment.....	145
8.	PERSONAL PROTECTIVE EQUIPMENT .....	156
8.1	General.....	156
8.1.1	Introduction .....	156
8.1.2	Types of PPE .....	157
8.1.3	PPE Programmes .....	157
8.2	Respiratory Protective Equipment .....	158
8.2.1	Introduction .....	158
8.2.2	General Use Limitations.....	159
8.2.3	Types of Respirators.....	159
8.2.4	Selection and Use of Respirators .....	170
8.2.5	Training.....	174
8.2.6	Wear Time .....	174
8.2.7	Respirator Fit Testing.....	175
8.2.8	Cleaning, Maintenance and Storage.....	179
8.2.9	Medical Evaluation.....	181

# TABLE OF CONTENTS

8.2.10	Record Keeping .....	181
8.2.11	Evaluation .....	182
8.3	Chemical Protective Clothing .....	182
8.3.1	Introduction .....	182
8.3.2	Types of Chemical Protective Clothing .....	183
8.3.3	Chemical Protective Clothing Materials .....	190
8.3.4	Standard CPC Test Procedures .....	195
8.3.5	Use of Chemical Protective Clothing.....	196
8.3.6	Inspection and Storage .....	198
8.3.7	CPC Limitations .....	199
8.3.8	Training.....	199
8.4	Gloves and Dermal Care .....	200
8.4.1	Dermal Exposure .....	200
8.4.2	Occupational Protective Gloves.....	203
8.4.3	Protection Against Chemicals .....	203
8.4.4	Selection of Gloves .....	207
8.4.5	Types of Gloves.....	208
8.4.6	Overall Glove Selection Process .....	210
8.4.7	Limitations of Gloves.....	211
8.4.8	Glove Removal .....	211
8.4.9	Reuse and Laundering of Gloves .....	212
8.4.10	Training.....	213
8.5	Eye and Face Protection .....	213
9.	ADMINISTRATIVE ELEMENTS.....	215
9.1	Introduction.....	215
9.2	Legislative Requirements .....	215
9.3	Reducing Periods of Exposure .....	216
9.4	Scheduling of Work .....	217
9.5	Maintenance and Housekeeping .....	217
9.6	Role of Eating, Smoking and Drinking.....	218
9.7	Changing Facilities and Clothing Storage and Laundering.....	219
9.8	Showers and Wash Hand Basins and Their Role in Preventing Exposure .....	220
9.9	Use of Creams and Lotions .....	221

# TABLE OF CONTENTS

9.10	Control of Access to Hazardous Areas.....	222
9.11	The Role of Assessment, Measurement, Monitoring and Health Surveillance in Initiating Control Measures.....	222
9.12	Role of Written Operating Procedures, Permits to Work etc.....	223
9.13	Role of Occupational Hygiene Programmes in Continuing Control .....	224
9.14	Importance of Education, Instruction and Training .....	225
9.15	Emergency Procedures and First Aid in High Risk Areas.....	225
9.16	Training .....	226
10.	PRACTICAL APPLICATIONS OF CONTROL STRATEGIES.....	228
10.1	Introduction.....	228
10.2	Addition of Hydrated Lime to Cyanide Tanks .....	228
10.3	Respirable Silica Exposure During Sand Blasting .....	230
10.4	Ventilation in a Laboratory Sample Room .....	232
10.5	Mercury Exposure in a Gold Room.....	236
10.6	Manufacture of Phthalic Anhydride.....	238
10.7	Control of Powders in the Pharmaceutical Industry .....	243
10.8	Diesel Particulate in Underground Coal Mines .....	249
11.	REFERENCES .....	256

## M SERIES COPYRIGHT AND LICENCE INFORMATION

The M Series syllabi are copyright © the British Occupational Hygiene Society (Faculty of Occupational Hygiene).

The student manuals and other training materials are distributed under [CC BY-NC-SA 4.0 Deed | Attribution-NonCommercial-ShareAlike 4.0 International | Creative Commons](https://creativecommons.org/licenses/by-nc-sa/4.0/) licence with the following attributions:

© The British Occupational Hygiene Society (Faculty of Occupational Hygiene) holds and licenses the copyright to the modular scheme for Occupational Hygiene education, module names, assessment guidance and organisation of content relating to:

- M200™ (previously W201™) Basic Principles in Occupational Hygiene
- M501™ (previously W501®) Measurement of Hazardous Substances
- M502™ (previously W502®) Thermal Environment
- M503™ (previously W503®) Noise – Measurement and Its Effects
- M504™ (previously W504®) Asbestos and Other Fibres
- M505™ (previously W505®) Control of Hazardous Substances
- M506™ (previously W506®) Ergonomics Essentials
- M507™ (previously W507®) Health Effects of Hazardous Substances
- M508™ (previously W508™) Skin
- ICertOH™ International Certificate in Occupational Hygiene

© Layout and design by the British Occupational Hygiene Society (BOHS)

© BOHS owns the content and original material in the substance of the following student manuals, as authored:

- M200 (previously W201) Basic Principles in Occupational Hygiene
- M504 (previously W504) Asbestos and Other Fibres
- M507 (previously W507) Health Effects of Hazardous Substances
- M508 (previously W508) Skin
- ICertOH International Certificate in Occupational Hygiene (all materials)

All other material is reproduced by BOHS under perpetual, non-exclusive licence from the original authors/Occupational Hygiene Training Association (2015).

BOHS would like to acknowledge the contributions of volunteers for the Occupational Hygiene Training Association (OHTA), as listed in the acknowledgements of this manual, including members of the British Occupational Hygiene Society and Brian Davies, OHTA founding Chief Editor.

BOHS would like to further acknowledge BP and GSK for funding the compilation and writing of the original materials and securing the licence to distribute them. The Society is indebted to Roger Alesbury and Steven Bailey, who as Presidents and Council Members of the British Occupational Hygiene Society:

- sought permission to use BOHS's modular scheme and syllabi for licensed use by OHTA;
- secured funding from BOHS, AIOH and IOHA to set up ohlearning.com;
- secured administrative support from BOHS to support the authoring, editing and setting up of OHTA training;
- secured approval from the BOHS Council to incorporate the Occupational Hygiene Training Association and to license it BOHS intellectual property under contract.

## Version History

This manual (M505 Version 1.0) is valid for 2024.

	Version	Release Date	Comments
W505	1.0	November 2009	Original version (W505)
M505	1.0	February 2024	Minor amendments to front matter and Course Overview including: - Renamed as M505 - Addition of M Series Copyright and Licence Information

## Feedback

We welcome feedback on this manual. Comments should be sent to the BOHS Qualifications Team at [qualifications@bohs.org](mailto:qualifications@bohs.org).



## ACKNOWLEDGEMENTS

This manual was originally developed by BP and University of Wollongong. The Occupational Hygiene Training Association Ltd would like to acknowledge the contribution of these organisations in funding and developing the material and is grateful for their permission to use and modify it.

Development of the manual was led by Brian Davies and John Henderson of the School of Health Sciences at the University of Wollongong, Australia. Considerable assistance was received from the following individuals or organisations and the authors would like to express their appreciation for the support received.

Adrian Hirst

Jen Hines

Ansell Limited

John Dobbie

BOC Australia Ltd

Kenelec Scientific Pty Ltd

David Bromwich

Microgard Limited

David Moore

Mike Slater

Dräger Safety Pacific Pty Ltd

Phil Johns

DuPont (Australia) Limited

Roger Alesbury

Erica Joseph

Steve Bailey

Gary Gately

Terry Gorman

Geoff Wilcox

## **SYMBOLS & ABBREVIATIONS**

ACGIH®	American Conference of Governmental Industrial Hygienists
AIHA	American Industrial Hygiene Association
AIOH	Australian Institute of Occupational Hygiene
BEI®	Biological Exposure Indices
BOHS	British Occupational Hygiene Society
COSHH	Control of Substances Hazardous to Health
CPC	Chemical Protective Clothing
ECA	Exposure Control Approach
ECEL	Exposure Control Efficiency Library
ECHA	European Chemicals Agency (Helsinki)
EPA	Environmental Protection Agency (USA)
ES	Exposure Standard
FAT	Factory Acceptance Testing
GHS	Globally Harmonised System
HOC	Hierarchy of Control
HSE	UK Health & Safety Executive
IARC	International Agency for Research on Cancer
IBC	Intermediate Bulk Container
IDLH	Immediately Dangerous to Life and Health
ILO	International Labor Organisation
ISO	International Standards Organisation
LOP's	Levels of Protection
MSDS	Material Safety Data Sheet
MVUE	Minimum Variance Unbiased Estimate
NFPA	National Fire Protection Association
NIOSH	National Institute of Occupational Safety & Health (USA)

**SYMBOLS & ABBREVIATIONS (Cont'd)**

OEL	Occupational Exposure Limits
OHC	Occupational Hazard Category
OH&S	Occupational Health & Safety
OPA	Ortho-phthalaldehyde
PAPRs	Powered Air Purifying Respirators
PEL	Permitted Exposure Limits
PPE	Personal Protective Equipment
PVA	Polyvinyl Alcohol
PVC	Polyvinyl Chloride
REACH	Registration, Evaluation, Authorisation and Restriction of Chemical Substances
REL	Recommended Exposure Limits
RMM	Risk Management Measures
SAT	Site Acceptance Testing
SCBA	Self Contained Breathing Apparatus
SMEPAC	Standardised Measurement of Equipment Particulate Airborne Concentration
TLV®	Threshold Limit Value
TWA	Time Weighted Average
WEL	Workplace Exposure Limits (UK)
WHO	World Health Organisation

# **1. COURSE OVERVIEW**

## **1.1 INTRODUCTION**

This Course has been based in the most part on the module syllabus M505 Control of Hazardous Substances published by the British Occupational Hygiene Society (BOHS), Faculty of Occupational Hygiene. The BOHS administers a number of such modules; further information on which can be obtained by visiting the BOHS website at [www.bohs.org](http://www.bohs.org). (Accessed July 2009)

At the time of publication every care has been taken to ensure that the majority of topics covered in the BOHS syllabus for the subject (M505) have been included in this Student Manual. Providers of training courses should check the BOHS website for any changes in the course content if they intend to participate in the BOHS assessment process.

The authors of this Student Manual take no responsibility for any material which appears in the current BOHS syllabus for Module M505 which is not covered in this manual.

## **1.2 AIM OF COURSE**

To provide an introduction to the methodologies and technology available to control workplace exposures and reduce risk to health from exposure to hazardous substances.

## **1.3 LEARNING OUTCOMES**

On successful completion of this module the student should be able to:

- Describe where and how airborne contaminants are generated by industrial processes, how this impacts on the control strategy and how control solutions can thereby be optimised.
- Recognise the range of approaches to risk reduction; the importance and value of using the hierarchy of control. The selection of appropriate strategies for implementation for all possible exposure routes including those of skin contact and ingestion.

- Describe the meaning of “adequate control”, particularly in relation to personal exposures.
- Discuss the importance of design considerations in terms of the workplace, process, and plant, as a means of reducing occupational exposures. Understand the importance of control at source and describe how that can be achieved.
- Describe the principal elements of containment systems and understand their limitations.
- Describe the principal elements of a local exhaust ventilation system, give examples of typical installations and know how to carry out the necessary measurements to assess whether a local exhaust ventilation system is effective and operating to the design specification, which will include an understanding of how to optimise the control provided by such systems.
- Describe the principal uses of personal protective equipment and the limitations and measures necessary to implement programmes in an effective manner as part of a control strategy.
- Recognise the impact that control measures may have on other workplace hazards and understand the need to take a holistic approach to the design of control solutions.

#### **1.4 FORMAT OF MANUAL**

This manual has been designed to follow for the most part the syllabus for this course as published by the BOHS. Similarly, the material provided in this manual has been aligned with the presentations for each topic so students can follow the discussion on each topic.

It should be recognised that the format presented in this manual represents the views of the editors and does not imply any mandatory process or format that must be rigidly observed. Presenters using this manual may well choose to alter the teaching sequence to suit their requirements.

In this regard the case studies and exercises are provided as illustrative examples and alternate material relevant to a particular industry may be used if desired.

In the final outcome, the aim of this manual is to transmit the principles of controlling the exposure of workers to hazardous substances.

## 2. WORKPLACE CONTROL PRINCIPLES

### 2.1 INTRODUCTION

The basic principles of identifying that a control is required in a specific situation, are derived from the first three key elements of occupational hygiene. These are described succinctly by Pependorf (2006) below:

- **Anticipation:** The prospective recognition of hazardous conditions based on chemistry, physics, engineering and toxicology.
- **Recognition:** Both the detection and identification of hazards or their adverse effects through chemistry, physics and epidemiology.
- **Evaluation:** The quantitative measurement of exposure to environmental hazards and the qualitative interpretation of those hazards.

**Control** is the fourth key element to occupational hygiene. It is a process of conception, education, design and implementation of beneficial interventions and changes carried out that eliminate, decrease or downgrade hazardous conditions.

Controls can be introduced to protect the health or comfort of workers along with other objectives, including employee safety, reduction in environmental pollution and reduction in economic loss.

Control involves changes to an operation or process to reduce exposure to a hazardous substance. The changes may involve substitution, technological changes, process modification, ventilation, the use of personal protective equipment and procedural or administrative changes with the aim of reducing the formation, release, transmission of, or contact with the substance of concern.

The primary reasons and objectives for control of hazardous substances include:

- Protecting the workers health from exposure to substances
- Protecting the workers comfort
- Complying with exposure standards

The decision about what to control is an important one that requires evaluation, including the identification of the important sources of exposure, through a survey that may or may not involve monitoring for hazardous substances to determine the levels that are currently in the workplace. The survey should involve observations of the process which may indicate other pathways of exposure in addition to inhalation, including skin or eye absorption or ingestion.

When developing a strategy for the control of hazardous substances, it is important to first understand all the risks and the ways in which workers may be exposed. It is essential to determine exactly what is causing the exposure – sometimes this is not as obvious as seems on first sight and how substances may contact the person – think of all routes – air, skin, and ingestion.

For example, if a worker is emptying a bag of powder into a hopper, it is tempting to look at controlling the airborne exposure from the bag emptying and concentrate on that aspect alone. Of course this may be necessary but it is important to look at what else is happening. What happens to the bag afterwards – often handling the bag and squeezing it down to reduce bulk can generate significant clouds of dust – sometimes even exceeding the emptying as a source of exposure. In this case it will also be important to look at what the workers are wearing on their hands – is skin contact a problem? Are they wearing respiratory protection – is it appropriate to the hazard concerned – is it clean and fitted properly? Are there any other problems such as high temperature or ergonomic problems? Only by fully understanding what is happening will you have a chance of implementing a successful control strategy.



When it comes to control, the most important tools at the disposal of the occupational hygienist are your eyes and ears. Stop in the area and look at what is happening and ask the question “how does the process operate, what do the workers actually do (not necessarily the same as what the procedures say they should do)?” Look for unexpected or other tasks that are required, such as periodic cleaning, maintenance, opening containment vessels. Look at the way the contaminants are generated in the work area but also look for other sources – leakage in containment, handling of empty containers, material moved through the motion of machinery or cross drafts generated by moving equipment.

Don't overlook the potential impact of skin contact – either direct from handling the material or indirect as a consequence of contaminated clothing or placing cleaning cloths in pockets. What happens when the worker finishes their shift or goes for a break – are there changing and washing facilities? (In the past it was common to use unrefined oils in machine shops. Skilled workers on lathes and other machines would wipe down machines with oily rags and place them in their overall pockets. This led to skin contact with the unrefined oil and cases of scrotal cancer in the industry. In those days, the immediate action was to improve handling of rags and better personal hygiene. Since then, the risk of cancer has been reduced though by the use of refined oils and substituting carcinogenic materials in metalworking fluids).

Is the type of clothing such that it can become contaminated with dust that can become airborne remote from the work area or even in their homes? (Cotton overalls can accumulate dust that becomes airborne with movement – in dusty industries, such as potteries, cotton is no longer used in favour of synthetic materials and regular laundering to avoid this problem.) Is there the potential for contaminated clothing to be taken home? (In the asbestos industry there are examples of the families of workers developing mesothelioma as a consequence of asbestos fibres being taken home on work clothing.)

Do workers wash their hands before eating, drinking or smoking? (Lead contamination on hands can be ingested. Lead contamination of smoking material can become volatilised and subsequently inhaled when smoked.)

How is the area cleaned? Where solvents are used for cleaning machine components this can create skin and airborne exposure potential. In dusty industries brushing can generate clouds of dust that can create an inhalation hazard – damping down with water or vacuum cleaning can be a better solution. Bear in mind though that a vacuum cleaner without a High Efficiency Particulate in Air (HEPA) filter will blow airborne dust through its exhaust that can actually increase exposure risk.

Listen to what the workers are saying – what do they think the problem is caused by? There is a need to be very careful in listening and being objective. Not all comments are necessarily valid but often they are and can identify issues that may not be immediately apparent. Often the worker will also be able to identify what may and may not work in terms of control strategies. Bear in mind that many control measures require intervention or use by the worker, so their views are important and it is vital they are involved in discussing control options. Workers and supervisors can often identify the part of the process that will cause the biggest problem in terms of the emissions or comfort. The occupational hygienist will need to be careful in interpreting this information and check out the information through observation and measurement but this discussion with workers can often lead to important findings.

Use survey equipment and monitoring to help characterise the problem. Use of dust lamps or direct reading instruments can help to identify sources of emission. Personal dosimeters with data logging can be used alongside a log of activities to identify when peak exposures occur and during what part of the operation. This can help to direct attention to sources of emission and hence control options.

Don't be afraid to try out ideas with pilot schemes before final commitment to a control strategy. For example, if you are thinking of enclosure or ventilation, sometimes it is possible to make a mock up in cardboard and sticky tape to see if it can work and to ensure this does not interfere with the work. Often it is only when the mock up is in place that it is recognised the design has to be modified to accommodate access or ergonomics.

Finally, don't forget that the work of the occupational hygienist is not complete until satisfactory control has been demonstrated and a strategy is in place for regular testing, inspection, maintenance and review in line with any good management system such as OHSAS 18001. Often the development of the strategy will require input from other specialists such as process engineers but it is always preferable for the occupational hygienist to remain involved until the risk has been shown to be effectively managed.

### **Step 1: Review the Risk Assessment and Understand the Hazards**

Any control strategy should be based on a risk assessment of the work and process. Review this in detail and ensure a full understanding of the nature of the hazards posed by the work. The range of substances used, generated or produced, their routes of entry and the hazards caused. Look also for other hazards that may complicate the approach to control – for example other protective equipment that could interfere with chemical protective measures, ergonomic or thermal conditions that could add to stress of the workers.

### **Step 2: Review Control Strategies from Similar Operations**

Is this a typical process for this industry? Is other information published in the literature on the risk and options for control? Suppliers of raw materials or process equipment or industry associations may have experience and guidance. Similar processes within the company or similar industries can also be used to assist in developing control strategies. Increasingly advice on control is also likely to be available from suppliers under regulations such as [REACH](#) in the European Union.

Reference material can certainly help in devising control strategies; however, every workplace and task can be different and it is essential to observe each situation and ensure the control measures are appropriate and specific to those particular circumstances.

### **Step 3: Stop, Look and Listen**

Spend time getting to know the workers and their supervisors. Understand the work process and observe what is happening. If you are doing exposure monitoring, use this as an opportunity to talk to the workers and help you understand what is happening. Where appropriate, use short term monitoring, direct reading instruments or data loggers to help characterise the particular tasks, or the parts of the process that contribute most to exposure.

By understanding how exposures vary, the specific times or tasks where exposures peak and the relative contribution to exposure and risk, it is often possible to target efforts to control exposures and achieve optimum results.

### **Step 4: Look at Options for Control**

Rarely will it be possible to eliminate exposures completely and a combination of control techniques will generally be necessary. Inevitably this will require workers to use equipment, procedures or protective equipment in particular ways - and so it is essential that the strategy devised is both practical and will be used in practice. The best designed controls are worthless unless they are used properly. For example, movable local exhaust hoods used in welding shops may be shown to be effective when carefully located in relation to the plume of fume. However, to be effective, they require careful re-positioning as the work changes or as the weld progresses. All too often these devices are not re-located as required by the welding task and thus provide little or no benefit for much of the time.

When it comes to actually controlling a substance, it is important to realise that others will also need to be involved.

For example, in all but the most simple cases it is likely that production engineers and maintenance staff will need to be involved with the design to ensure there is zero to minimal interference with production. Other health and safety staff will also need to be involved to ensure that all health and safety aspects are considered.

### **Step 5: Effectiveness of Controls**

In terms of reducing risk to a workers health, the act of controlling exposure is the element of occupational hygiene that actually benefits workers. Given this, it is important that any control strategy that is introduced be maintained at an appropriate level.

In the case of engineering controls, such as local exhaust ventilation, this will require regular visual checks and at least annually a thorough examination and test.

Finally, effectiveness should be checked by periodic reassessment and exposure monitoring if appropriate – closing the loop on the management cycle.

#### **2.1.1 Control Challenges**

The commonest challenge to implementing any type of exposure control or risk reduction technique is cost. In the real world, all too often optimum control strategies are considered too expensive, and compromises are made, which can place an over-reliance on the use of personal protective equipment. The materials in this manual and the course itself should provide the means for an occupational hygienist to provide good evidence on what the best control strategy is, and help the people in charge of the budget, understand the true costs and benefits of both the optimum solution and any alternatives.

The reasoning behind these control cost challenges are often wrong, as good control can bring direct financial benefits in addition to the indirect ones associated with worker protection.

For example a major chemical manufacturer looked at control options as part of a wider loss prevention study, and calculated that even the more expensive options around engineering controls had a surprisingly short payback period, owing to the savings on keeping a very expensive product “in the pipe” and hence available as a marketable resource rather than a wasted emission.

The occupational hygienist should therefore consider aligning with his process safety and environmental colleagues, as the aims of each of these individuals in terms of “control” is very similar and a holistic approach can both save money and be more effective.

The indirect financial benefits, around worker protection result from better working conditions’ leading to higher morale, and hence increased productivity, less absence, greater staff retention with attendant reduction in recruitment and training costs etc. All of these can add up to a substantial amount, and in most cases will readily surpass the outlay for a proper control solution.

## **2.2 HIERARCHY OF CONTROL**

### **2.2.1 Prioritisation of Control Methods**

There are many different measures that can be implemented in order to control exposure to hazardous substances. Some measures are preferable to others and it is possible to develop a list of measures in order of priority. Such a list is commonly known as a “Hierarchy of Control” (HOC). There are several different versions of the HOC mentioned in text books and journals. However, they are all based on the same basic principles.

The hierarchy can be developed by considering **where** the controls can be applied and also which **type** of control is likely to be most effective.

There are three "zones" where control measures can be applied:

- at the **source** of the contamination
- along the transmission **path**
- at the **worker**

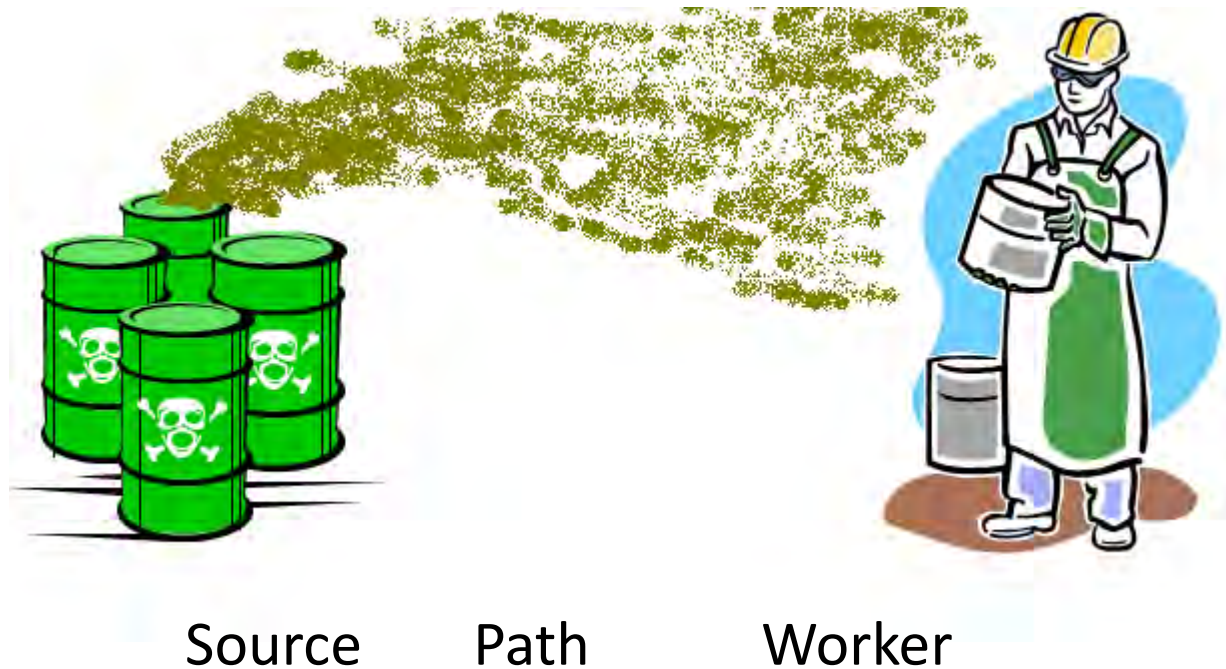

(Source: Diamond Environmental Ltd – reproduced with permission)

**Figure 2.1 – Basis of the Hierarchy of Control – Control Locations**

Taking account of the risk assessment and all potential sources of exposure – air, skin, ingestion - the best way to achieve control is by addressing the source of the contamination. If this cannot be achieved or does not resolve the problem then an attempt should be made to control along the transmission path. Only if neither of these can be achieved should the primary control measures be based around the workers themselves. Measures that can be applied at the **source** of the contamination include:

- Eliminate the source
- Substitution – using a less hazardous chemical or process
- Isolation / containment / enclosure – enclose sources or the employee, or the source and some employees together rather than all employees

- Modification of the source or process
- Automation – use robotics, remote or computer aided products
- Separation – place the source in a different location to the employee
- Local exhaust ventilation – using ventilation to capture the contaminant at the source, to prevent it dispersing

Control along the **path**, when the contaminant is dispersing, is more difficult and fewer options are available. They include

- General ventilation – which dilutes the contaminant concentration
- Increasing the distance between the source and the workers (ie: increasing the length of the pathway so that there is more dispersion and dilution)
- Use of screens and partial barriers

**Worker** based controls include

- Administrative controls – rotating workers, limiting the length of time they work in a location
- Personal protective equipment (PPE) – wearing something that stops the contaminant affecting you, even though it has already reached the worker

Note that these categories are not definitive. There is a degree of subjectivity when deciding which category a particular control belongs to and, indeed, some controls could be considered to fit into more than one category. For example, some texts consider containment and local exhaust ventilation to be pathway controls, however it is important to recognise that containment and local exhaust ventilation, being applied close to the source, are usually much more effective at controlling exposure than general ventilation, other controls located along the path or worker based controls.

Control measures can also be classified as follows:



- Prevention
- Engineering Controls
- Procedural / Organisational Controls
- Personal Protective Equipment

When deciding on what controls can be used, start at the top and work down the list considering each measure in turn, and try to use measures towards the top of the hierarchy. This means that although Personal Protective Equipment (PPE) can often be used, it should not be the first choice when controlling exposure to a hazard.

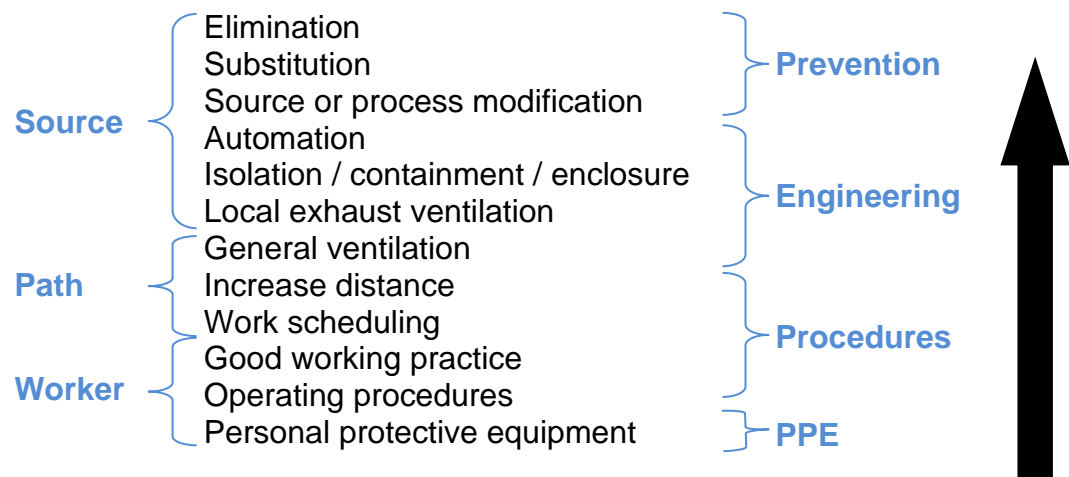

**Figure 2.2 – One version of the Hierarchy of Control**

In many countries the hierarchy of control is part of the legislation and it is not acceptable to apply PPE when there are more suitable controls further up the list of the hierarchy that could be applied with more effective control of the contaminant.

In addition, another factor, to take into account when selecting suitable controls from the hierarchy, is the nature of the task or process to be controlled. Is it a permanent task or process; or is it a short-term action resulting from infrequent maintenance activities, eg: those associated with plant or equipment shutdowns/turnarounds etc? It is more acceptable to consider the use of PPE in the latter situations, for example, than as a long-term solution to a full-time production process. Similarly the costs involved in

selecting controls from the top section of the hierarchy may not be justifiable against the risks for short-term activities.

### 2.2.2 Key Elements of the Hierarchy of Control

- **Elimination**

Eliminating a hazard by removing a process or substance completely is the best solution. For example, is the process really necessary or are there other alternatives. This may not be practicable in the short term for established major processes but can often be applied in construction, new projects, maintenance or other short term activities. For example, a company wanted to pressure test a vessel by water which required the removal of refractory materials from inside the vessel. This would have meant exposure to dust, noise, high temperatures and range of safety issues associated with working in a confined space. The occupational hygienist spoke to the engineers and asked “Why?” They looked at other similar activities and found this testing could be completed satisfactorily and more safely by pressure testing with nitrogen – this required no need to enter the vessel and no need to remove the refractory.

If a hazard cannot be eliminated, then consider the next steps in the hierarchy.

- **Substitution**

Substitution involves changing chemical substances and/or processes with a less hazardous one. The process of substitution has been used throughout history. A good example is the white and yellow phosphorus matches that were responsible for ‘phossy jaw’. Phossy jaw was a disfiguring and potentially fatal necrosis of the jawbone in matchmakers. White and yellow phosphorous was replaced with less dangerous red phosphorus matches and modern safety matches incorporate an even safer tetraphosphorus trisulphide in the striking friction part of the box (AIOH 2007). However, it is always important to consider whether the new material may introduce other risks or may have hazards that are yet not fully understood.

A major consideration around substitution is our knowledge and understanding, or rather lack of it, on the hazardous nature of the chemical substances we are dealing with. There are considered to be upwards of 300,000 substances in use around the World, and of those we currently have detailed toxicological information on less than 10% of them. Simply substituting a known hazardous chemical with one that does the same job, but of which we have no real hazard data is not a sensible approach, as we could actually be making the situation worse.

In addition the drive for substitution is not restricted to concerns around human health only. Environmental legislation often drives substitution decisions, and this can sometimes negatively impact on human health risks. For example the replacement of chloro-fluorocarbons (CFCs) in pressurised aerosol dispensers, and chlorinated hydrocarbons as general-purpose solvents under the Montreal Protocol to reduce ozone-depleting chemicals in the upper atmosphere, resulted, in some cases, in more hazardous agents, from the perspective of human health, being utilised.

- **Modification**

Modification means to change the physical operating conditions without changing the chemical or process. A process may be wetted down to reduce dust, or temperatures can be decreased to reduce vapour pressure and the volatility of a chemical.

- **Containment**

Containment of the source of the hazard by placing the hazardous substance in a sealed vessel or systems can be a very effective way of creating a barrier between the hazard and the person. For example, road tankers used to be filled with gasoline by loading through a hatch at the top. The operator would be potentially exposed to displaced vapour. Nowadays, most gasoline tankers are loaded by 'bottom loading' where the tanker is connected by hose as a closed system and displaced vapours are taken out by another hose to a vapour recovery system.

- **Automation**

Automation is the use of some form of robotics to replace a function previously provided manually by an exposed worker. For example, robotic welding in automobile manufacture has reduced the need for manual welding. Other examples from the mining industry include the use of machinery for cutting coal that has reduced the number of miners at the coal face. Reduced levels of manual tasks by introducing even limited automation can assist in reducing a workers exposure but may introduce other safety hazards. Caution may be required when looking at the other activities required when automation is introduced. For example, there may then be requirements for maintenance and cleaning activities that will need risk assessment and control.

- **Isolation**

Isolation is the separation of the source and the worker by a physical barrier such as an enclosure, wall or partition. Partitions are not as effective as complete enclosures, and additional controls may be needed.

If a worker can be completely removed or isolated from the hazard, the risk to health is removed.

An example of isolation is the use of interlocked doors or barriers to prevent entry into an area while toxic substances are present.

It should also be noted that isolation marks the part of the hierarchy where the “human factor” issues, such as competence, behaviour, motivation etc. really start to influence how the workers actually use the specified controls, and from here on down the hierarchy, the potential for “human error” increases.

- **Ventilation**

Ventilation is the use of air movement to remove, displace or dilute concentrations of the contaminant.

Local exhaust ventilation, which involves removing the contaminant from the workplace near its source, is versatile and can be a more effective long term control than general room or dilution ventilation.

Displacement ventilation, involves the use of air flow to create flow conditions where the worker is in a cleaner air stream and the contaminated air is downstream. Dilution ventilation involves adding more fresh air to the workplace to dilute a chemical. This can still result in exposure, but to a diluted product.

All forms of ventilation may play a role in certain circumstances as part of a control strategy. However, the effectiveness of ventilation is often over estimated and can, for many practical reasons be ineffective in practice. Ventilation will only be effective where the characteristics of the source of the contaminant is properly investigated and understood and where work has been done to show the impact of the airflow on the contaminant.

- **Procedural Controls**

Procedural or administrative measures are worker based controls which reduce the received dose of a particular hazardous agent. Dose can be reduced by decreasing the amount of time a person is in a particular area (job rotation), and by reducing the number of employees exposed by conducting certain operations when less workers are present. Pependorf (2006) considers that duration, frequency and number of people exposed make up Administrative controls, however good housekeeping, training and supervision are also included in this category. Good housekeeping removes contaminants which result in reduced airborne, dermal and ingestion exposure. Training workers to anticipate and avoid the cloud of contaminant reduces exposure. Some countries consider training and housekeeping to be part of modification.

Administration relies on personal behaviour to control a hazard.

- **Personal Protective Equipment**

Personal Protective Equipment (PPE) involves wearing additional clothing, gloves, and/or respirators to reduce exposure to a chemical. It is not the first choice but may be an appropriate form of control where other choices are not practicable, or in combination with other measures where the nature of the hazard requires a layered level of protection. To be effective, PPE has to be selected to be technically appropriate, properly fitted - accounting for each individual's own physical attributes; put on, worn, removed, cleaned, maintained, tested, stored and disposed of safely and appropriately. In practice, suitable and proper PPE management programmes are very difficult to achieve and maintain. Poor or improper PPE management programmes are easy to implement and unfortunately are all too common. Only one of the two programme types will, however, offer any protection to the worker! Using PPE can also be more expensive in the long run, than other controls selected from higher up the hierarchy. .

### **2.2.3 Using a Combination of Controls**

In many cases, it will be necessary to use a combination of measures to appropriately manage exposure to a risk. For example, a toxic chemical could be replaced with a less hazardous one (substitution), safe work procedures (administrative measures) introduced, and personal protective equipment provided for workers to use.

*Example: Sandblasting*

Although still termed 'sandblasting', sand, which is high in quartz has been replaced with garnet or ilmenite, which is very low in quartz (substitution). Due to the nature of the work, the sandblaster cannot be removed or isolated from the task, so although they will still be exposed to dust they are exposed to a less harmful dust and they are also required to wear protective clothing, including hood and air supplied respiratory protection. Noise is possibly the next worst exposure when sandblasting and this requires different controls again. Isolation can be used to protect other workers from sandblasters.

This is achieved by having specially designed booths where sandblasting activities are conducted and therefore other workers are not exposed to the dust or noise generated. However, it is important to have a viewing window in the booth to allow for observation of the sandblaster.

So, in practice it is common for a control strategy to include a number of measures – often in combination to provide layered defence. In particular, for environments that might be immediately dangerous to life or health, it is appropriate to build in several layers of protection. This concept is commonly presented as an of material moving through layers of cheese containing holes (Swiss Cheese) and can be illustrated diagrammatically (Figure 2.3).

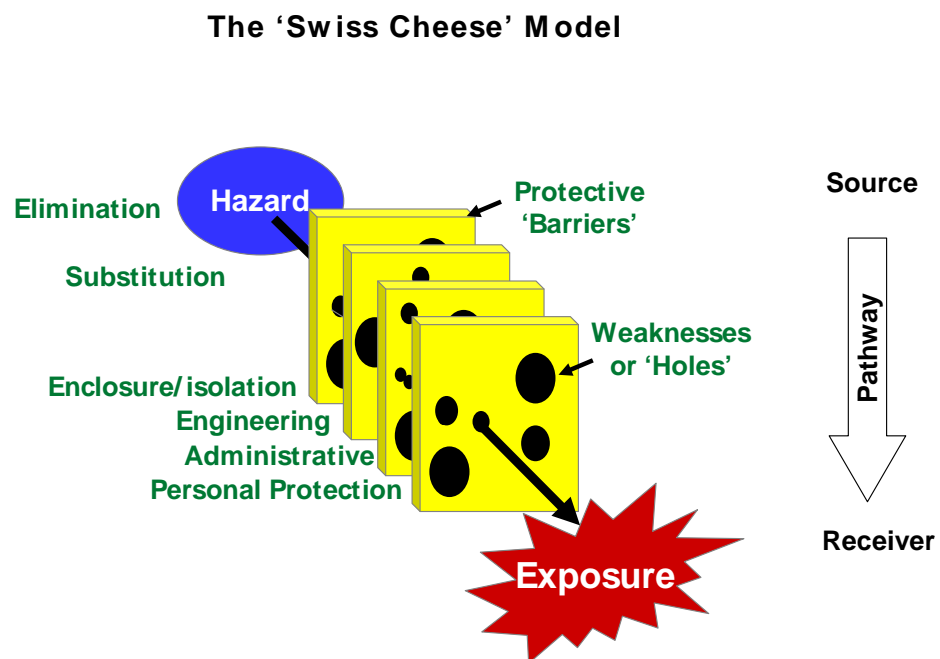

(Source: BP International Ltd)

**Figure 2.3 – The “Swiss Cheese” Model – Showing the need for Multiple Measures to Control Exposure Effectively**

So, for example, on a plant handling hydrogen fluoride, there will be a range of engineering controls to maintain enclosure. Access to work areas is strictly controlled and people going into process areas will wear protective equipment. If there is even the remotest chance of broken containment or release, full chemical protective clothing and breathing apparatus will be used – not as the first line of defence but as a back up.

All of these will be supported by work methods, procedures, training and rigorous procedures for selection, maintenance, cleaning and use of the PPE.

In many cases a single control solution does not exist and a solution that works at one site may not do so at another. This issue can be demonstrated by the work of Davies (2004) who highlighted the need for multiple control technologies to minimise employee exposure to diesel particulate in underground coal mines. Davies (2004) established that although different control approaches resulted in varying levels of reduction in employee exposure to diesel particulate, there was no single control that could be used to cover all possible situations.

#### 2.2.4 Managing Controls

No matter how good the controls applied to solve a particular problem they can only be effective if they are used, and used properly. They also need to be properly maintained and managed effectively.

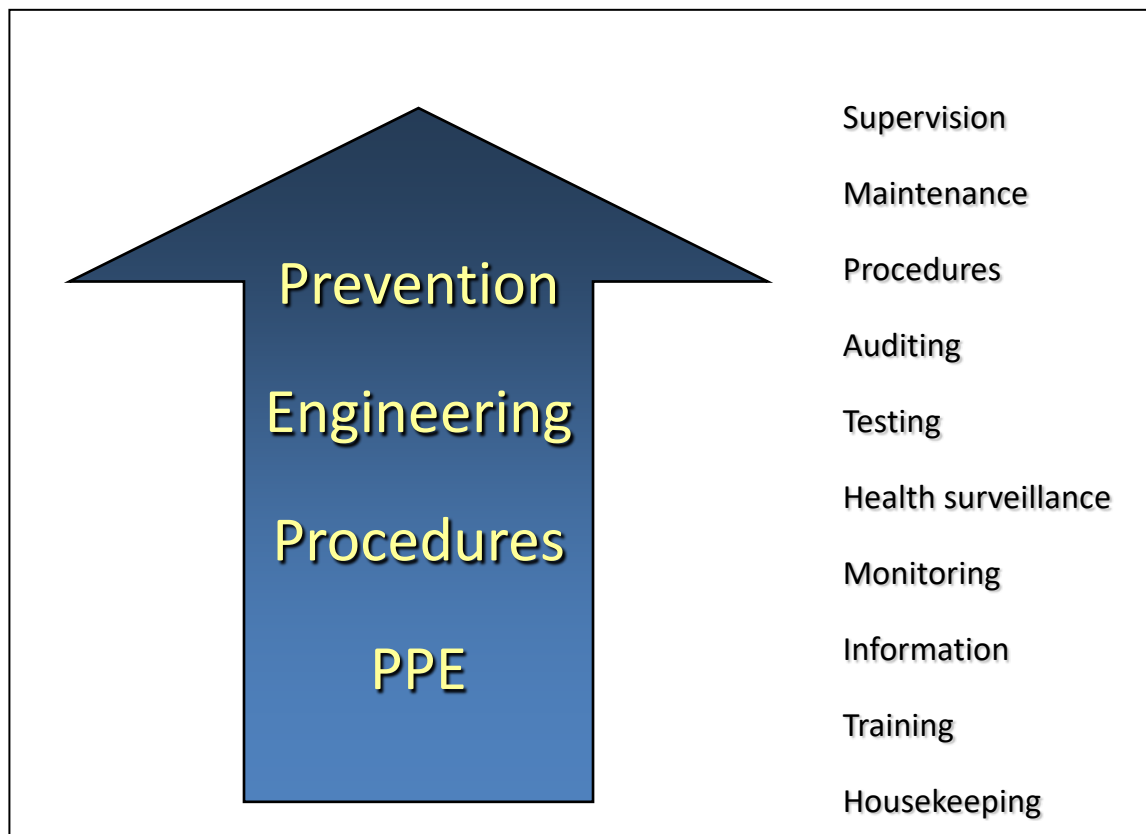

(

Source: Diamond Environmental Ltd - reproduced with permission)

**Figure 2.4 – The Hierarchy of Control – The Role of Management Controls**



There are many examples where expensive control measures are installed only for them to remain unused, used infrequently or used incorrectly or poorly maintained, thereby rendering them ineffective. Management measures therefore need to be put into place to ensure that the controls continue to work effectively. Such measures are likely to include:

- **Supervision** to ensure that the procedures are followed
- **Maintenance** to ensure that engineering controls continue to operate effectively
- **Testing of controls**, which should apply to organisational measures as well as engineering controls. In the case of engineering controls, such as local exhaust ventilation, this will require regular visual checks and a thorough examination and test at least annually
- **Air monitoring and health surveillance**, which are, effectively, additional checks on the effectiveness of controls
- **Information, instruction and training** to ensure workers know why the controls are needed, how to use them correctly, procedures for reporting faults etc. For example, workers should be trained in the hazards of the materials, the procedures and control measures necessary and how to use them effectively. In the case of Respiratory Protective Equipment (RPE), for example, this will include careful selection of the equipment to provide appropriate protection and to suit the individual's facial characteristics. It will also include fit checking and quantitative fit testing to ensure appropriate protection as well as information, instruction and training on the wearing, cleaning and maintenance
- **Emergency procedures** for dealing with leaks, spills, failure of controls etc
- Good **housekeeping** practices, to minimise accumulation of contaminants



(Source: BP International Ltd)

**Figure 2.5 – The Health and Safety Management Cycle**

Finally, the effectiveness of the control strategy as a whole should be checked by periodic reassessment and exposure monitoring if appropriate – closing the loop on the management cycle (Figure 2.5).

### **3. DESIGNING CONTROL STRATEGIES**

#### **3.1 INTRODUCTION**

Controlling a risk from an occupational hygiene hazard relies on recognising and understanding that the risk exists and knowledge and experience of how to protect the worker in the circumstances in which the hazard is present. So the key to implementing an effective control strategy is to ensure that a risk assessment has been undertaken.

When determining a control, a number of different considerations are required, and these considerations must be made in conjunction with workers, supervisors, engineers, other HSE colleagues and manufacturers.

Consideration must be given to:

- The hazard and the extent of the risk it poses
- The practicality of various controls
- The effectiveness of different controls
- The consequences of failure of controls
- The relative costs of providing, operating and maintaining controls
- The acceptability by the workforce

The Australian Institute of Occupational Hygienists (AIOH 2007) considers that before an occupational hygienist embarks on any control programme it is essential that time is taken to fully understand the hazard and:

- How the hazardous situation arises
- What the exposed people are doing at the time of exposure
- Why they are doing the task
- What the intended outcomes are of the control programme or task
- What the impacts on other people nearby are and, importantly
- What the consequences are if the controls are not adequate or fail to protect the worker

Once information on exposure has been obtained (for a quantitative risk assessment this will need to be evaluated to cover all situations and exposure rates), some estimate of risk can be obtained by considering this and the hazards involved.

The risk may generally be described as 'significant' or 'not significant'. The risk can be regarded as '**not significant**' if it is unlikely that the work will adversely affect the health of people in the workplace.

A '**significant risk**' means that the work is *likely* to adversely affect the health of people in the workplace. For example, there would be a 'significant risk' if:

- Exposure is high or the substance used is highly toxic;
- A dangerous reaction with other substances might occur; or
- It is reasonably foreseeable that leaks or spills of a hazardous substance might occur

In the event of a significant risk being established it is important that actions are taken to ensure that the risks are adequately controlled. In these circumstances, further work may be required to ensure that control measures are implemented and maintained. This could include the need for regular workplace monitoring and, in some situations, health surveillance. Thus, if the risk assessment indicates a significant risk then further actions are necessary to control the risk.

The process of risk evaluation provides a list of risks requiring control, often with priorities. The next step in the process involves identifying a range of control options for minimising these risks, evaluating those options, developing appropriate control technologies and implementing them in the workplace.

Development of options to control individual risks will seldom occur in isolation and should be part of an overall strategy.

Having a clear understanding of a complete strategy is important to ensure that critical links are maintained.

It is wise in the development of any control strategy to be flexible and be prepared to consult with stakeholders as well as specialists. It is important that workers have an appropriate level of participation in this process if the controls are to be effective and sustainable.

It is important to ensure that all categories of hazards applicable to occupational hygiene are considered when controlling a source. Therefore chemical (dusts, fumes, gases, vapours, mists etc), physical (noise, vibration, thermal, lighting) and biological (bacteria, fungi, viruses etc) hazards must be anticipated and considered. However, in addition to this, ergonomic (how the workers interact with machines and equipment), mechanical (safety aspects), and psychological (peer pressure, stress, education) hazards must also be considered. In some cases these can be more difficult to assess, and expert assistance may be required. A number of the above hazards are outside the scope of this manual and will not be discussed.

The implementation of a control should mean the reduction of exposures and minimising the risk of adverse health effects, however success can only be considered achieved when the controls are accepted by the workforce and are sustainable over the long term.

If a task is only conducted intermittently, ie: once a year for two days, then it may be acceptable to supply appropriate respiratory protection (with appropriate fit testing, maintenance and training) rather than modify the system.

If a worker worked on a dusty task in a production line each day, it would not be appropriate to provide that worker only with respiratory protection. At the very least, investigations should take place to look at ways of reducing the emission of dust at source, containment, ventilation or other controls alone or in combination to reduce the reliance on PPE.

It is generally more cost effective to make changes prior to the commencement of a process or activity. The design phase is the ideal time to make changes to a source. If engineering and ventilation is anticipated and designed for in the construction phase of a plant, the costs are generally not significant, however, altering a process following commissioning can involve significant amounts of money. Retrofitting is often expensive and is usually not efficient.

When adding a control following commissioning, it is important to involve all stakeholders to ensure ownership of the solutions.

### 3.2 A STRUCTURED APPROACH

There are many things that need to be taken into consideration when designing appropriate controls. The flow diagram in Figure 3.1 illustrates a structured approach that can be used by a team designing and implementing a control strategy. Each of these steps is discussed in the following sections.

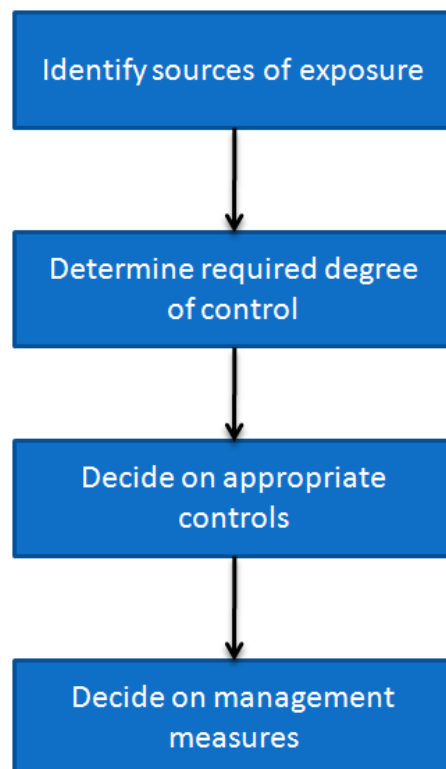

(Source: Diamond Environmental Ltd - reproduced with permission)

**Figure 3.1 – A Structured Approach to Designing Contaminant Controls**

Often the development of the strategy will require input from other specialists such as process engineers but it is always preferable for the occupational hygienist to remain involved until the risk has been shown to be effectively managed.

For an existing process, the key to carrying out a thorough risk assessment and designing an effective control strategy is to undertake a thorough inspection of the process and workplace. When controls are being specified at the design stage this will not be possible; however, there may be other similar processes in operation that can be reviewed for 'lessons learned'. In such cases it may be possible to review control strategies that have been implemented successfully on similar processes and to look for guidance from regulatory authorities and other organisations. It may also be appropriate to look around the proposed location of the process to ascertain the feasibility of any conceptual control strategies.

### **3.3 IDENTIFYING SOURCES OF EXPOSURE**

The key to effective control of hazardous substances from a particular process is to identify all the sources which can contribute to the exposure to the workers and other people who may be affected.

In most cases there will be a number of different sources of exposure, including both **primary** and **secondary** sources. For example during a manual process where bags of powder are emptied into a mixing vessel, the primary source of exposure will be the airborne dust generated during emptying. It is important to remember there can be other, less immediately obvious, but still primary exposure sources, such as the dust generated during the disposal or handling of the emptied bag when residual powder can be released. Secondary exposures result if dust from the primary sources settles out onto work surfaces, or floors where it can be disturbed and re-entrained into the atmosphere.

The **primary** source of exposure is the main source of exposure, and is the part of the process from where the contaminant is originating. **Secondary** sources of exposure can also occur and can easily be overlooked. Another example of a secondary source occurs in the handling of mercury. Due to the nature of mercury, it can often be spilt in use and can easily and insidiously move to and contaminate different areas of a workspace. Mercury is able to penetrate plaster, wood, paint and other building materials such as cracks in floor tiles. This stored mercury can then generate mercury vapour which results in air contamination, and the exposure of unsuspecting people. This contamination is not seen, and it may not be until the primary source has been removed, such as a laboratory closing down, and the workspace is used for something unrelated that the realisation that secondary contamination exists. Secondary contamination also contributes to the exposure levels of the workers that were originally using the product. Thus all workers are potentially being exposed to the primary source, ie: the mercury they can see and the vapour that is coming off it at the time, and then the secondary source, where the material has penetrated building materials and furnishings and is also generating vapours, in addition to any dermal contamination.

It is also important to remember that exposure can be by other routes than inhalation, skin contact being particularly important (although ingestion and skin penetration and injection can be important in some situations) All sources need to be identified and a decision made on which contribute significantly to exposure.

There may be several sources of exposure to a particular substance or exposure to a number of substances that act in the same way on the body, causing an increased negative health effect.

For example, in a printing facility, exposures can arise from evaporation or contact with any of the following:



- Spare inks and solvents waiting for use
- Discarded ink containers in open bins/spaces – ie: discarded due to wrong colour; malfunctioning unit; finished container with residual waste remaining
- Open drums and containers of inks and solvents
- Inks actually in use in the printing machine
- Residual inks on the printed paper
- Solvents used in cleaning the machine or other spills
- Residual solvents on the paper/rags used for cleaning

If more than one type of solvent is used, then the possibility of additive effects on the body needs to be considered. These exposures can occur via inhalation, skin absorption or any other routes of exposure. All routes of exposure need to be taken into account.

For an existing process, exposure sources can often be identified by observation and by talking to personnel who operate the process. Instruments such as short term monitoring, direct reading instruments can be used to help characterise the particular tasks, or the parts of the process that contribute most to exposure. Techniques that help to visualise contaminants (eg: dust lamps) or show how the air is moving (eg: smoke generators, air current tubes) can also aid identification and characterisation of airborne sources. Fluorescent tracers can help to reveal sources of contamination which could result in skin exposure or accidental ingestion.

Personal dosimeters with data logging can be used alongside a log of activities to identify when peak exposures occur and during what part of the operation. This can help to direct attention to sources of emission and hence control options. Figure 3.2 shows the results from a ToxiRae® direct reading personal monitor. This is used to sample how an individual's real time exposure varies so attention can be directed to those tasks that contributed to the individual's exposure.

Caution must be exercised, however, to ensure that any limitations, around the monitoring methodology are recognised and taken into account, eg: in the example shown in Figure 3.2 the peak exposures associated with the “Painting” task may not necessarily be as low as they are depicted. This is because the response of the instrument to the paint may be significantly less - relative to its response to isobutylene, which the instrument has been calibrated with. In practice, therefore, accounting for the relative responses between the paint, isobutylene and acetate ester, the paint concentrations could actually be higher than the acetate ester, and neither will bear any relationship to the level of exposure shown on the ppm scale on the left, unless the relative detector response factors are known.

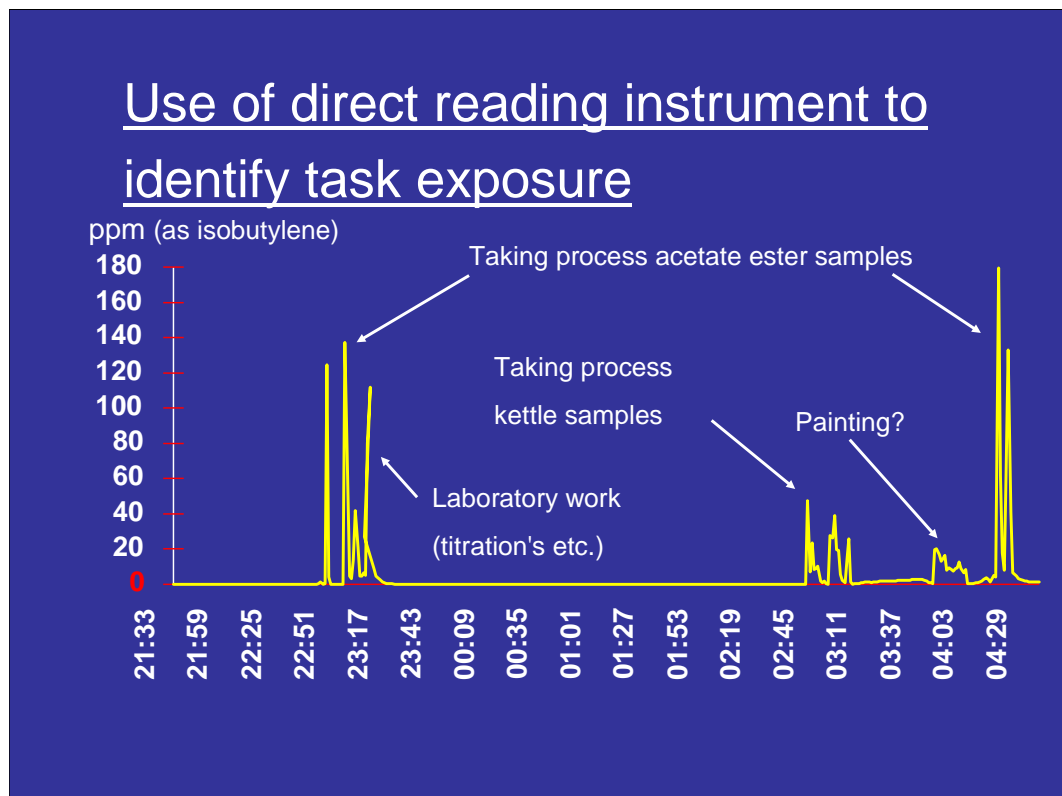

(Source: G Wilcox, BP Chemicals Ltd)

**Figure 3.2 – Direct Reading Monitor Readout**

By understanding how exposures vary, the specific times or tasks where exposures peak and the relative contribution to exposure and risk, it is often possible to target efforts to control exposures and achieve optimum results.

Further details on how contaminants are generated by processes and how they can give rise to sources of exposure are provided in Section 4 of this manual.

Once the principal sources of exposure and the substances involved have been identified, the hazardous properties of the substances need to be determined. Information on hazards will normally be provided by suppliers of substances used in industry on labels and in safety data sheets.

### **3.4 DETERMINING THE DEGREE OF CONTROL REQUIRED**

The degree of control required really depends on the extent of the risk of exposure. The greater the risk, the more comprehensive the controls need to be. However, it is not always easy to make a decision on this.

Where it is possible to obtain information on the level of exposure and an appropriate occupational exposure standard is available, a comparison of the two will allow a judgement to be made on whether exposure is adequately controlled or whether additional controls are needed. The more the limit is exceeded, the more comprehensive the control strategy needed.

If this information is not available then observations and the results from qualitative tests (eg: using visualisation techniques such as smoke, air current tubes or dust lamps) can assist in a professional judgement. Where there are obvious signs of contamination, such as visible dust clouds and contaminant spread around the workplace, it is likely that improved controls will be needed. On the other hand, where only small quantities of low hazard materials are being used, then comprehensive controls may not be required. A team based approach will make such judgements easier.

#### **3.4.1 Adequate Control**

Adequate control applies when a threshold can be established, and exposure is below this threshold. If an exposure threshold for safe use cannot be established (for example with some carcinogens), then the question of adequate control cannot be conclusively addressed by compliance with an exposure limit.

If this is the case, additional safeguards to ensure that exposures are minimised to the lowest level practicable should be introduced. Adequate control is achieved when exposure to humans or the environment at any point in the life cycle of the chemical is kept below an exposure level which could potentially cause harmful effects to humans or the environment.

### **3.4.2 Occupational Exposure Limits**

Control may be achieved by ensuring that occupational exposure limits are complied with, however this has limitations. Many exposure standards are only applied to substances that are inhaled, and exposure is also possible through ingestion, eye and skin absorption (including injections). At times, exposure can occur simultaneously through two or more routes of exposure. All routes of exposure must be considered to control a substance adequately.

Exposure standards are also generally derived for a specific type of person, for a specific time; ie: "The TWA concentration for a conventional 8-hour workday and a 40-hour work week, to which it is believed that nearly all workers may be repeatedly exposed, day after day, for a working lifetime without adverse effect" (ACGIH® 2009).

Most limits refer to the average concentration over a given reference period, - "time weighted average" or TWA. In most cases the reference period is either 8 hours (for substances that have a long term, "chronic", effect) or 15 minutes (for substances with short term, "acute" effects), known as short term exposure limits or STELS. As most substances have both long and short term effects, they often have limits based on both time periods.

Many people in the occupational environment fail to understand that exposure standards are not fine lines between safe and unsafe but are merely guides for the use of occupational hygienists in the control of potential health problems.

In countries or jurisdictions where occupational exposure standards are used as regulatory limits they are of course legally binding and not guidelines.

Their application to situations outside the norm (eg: 12 hour shifts) for which they were designed should only be considered by persons experienced in their interpretation. Effects such as synergism and potentiation, addition etc need to be understood and allowances made.

With many new products coming onto the market, it is impossible for any standard setting organisation (statutory or professional) to develop appropriate exposure standards for each compound before they are in commercial use. With this in mind, analogy to other compounds of similar type, common-sense and good occupational hygiene practice may reduce any unnecessary exposure.

It should be noted that regulatory standards usually include consideration of many policy concerns, such as engineering feasibility, economic impact, analytical limits etc. Non government guides such as the American Conference of Governmental Industrial Hygienists (ACGIH®) TLVs® and the Workplace Environment Exposure Limits from the American Industrial Hygiene Association (AIHA) are usually health based and do not take any other factors into consideration.

Occupational Exposure Limits (OELs) such as the Threshold Limit Values (TLVs), apply only to the workforce. In deriving OELs it is presumed that workers are in reasonably good health. Industrial environments usually exclude the very young, the very old and those unable to work due to illness and physical impairment or disability.

OELs are generally described in supporting information as not being fine lines between safe and dangerous conditions and should not be used by anyone who is not trained in the discipline of industrial/occupational hygiene. They were never intended to be absolute standards; however this has occurred in some countries.

The ACGIH® has set their standards based on the concept that each individual will react differently to the same substance at the same concentration. Exposure standards can be based on irritation, neural effects, damage to organ systems such as blood, kidney or liver, or the risk of acute effects, chronic disease and cancer. Therefore a good understanding of how the exposure standard was derived is important in understanding adequate control and the documentation supporting the limit value should be consulted.

A more detailed discussion of exposure standards can be found in the student manual for the “Measurement of Hazardous Substances” module.

### **3.4.3 Applying Occupational Exposure Limits**

The type of substance that is being evaluated is important in determining controls. If a substance only has an 8-hour TLV® and no short-term exposure limits or associated health effects, high exposures for short periods may have limited consequence eg: lead, crystalline silica.

However, for substances with short term or peak limits that have short-term health effects, such as irritation or central nervous system depression, short duration, high exposures are likely to be important eg: sulphur dioxide, carbon monoxide, toluene.

#### **Example 1**

A belt-splicing operation uses a toluene based product to glue together two pieces of conveyor belt to form one long conveyor belt. The process of gluing takes 10 minutes, 7 times a day. Clean-up occurs once per day at the end of a shift and takes 15 minutes. To work out which area to control you must first determine where most of the exposure is occurring. Let's take an example where exposure standard for toluene is 50 ppm and the STEL is 150 ppm (the limit may differ, depending on the particular country).

Process	Exposure (ppm)	Duration (mins)
Background/General	20	325
Gluing	80	7 x 10 minutes
Cleanup	160	15
TWA 8hr Exposure of Operator	30	

The TWA 8 hour is 30 ppm, this is under the Exposure Standard (ES) of 50 ppm. However the cleanup process takes 15 minutes and is over the STEL of 150 ppm. Therefore the cleanup part of the process requires control and would subsequently slightly reduce the overall TWA.

$$\text{TWA} = \frac{(20 \times 325) + 80 (70) + (160 * 15)}{480}$$

$$= 30 \text{ ppm}$$

### Example 2

n-Butyl acrylate is used in the production of coatings and inks, adhesives, sealants, textiles and plastics. It has an 8 hour exposure standard of 5 mg/m<sup>3</sup> and a STEL of 26 mg/m<sup>3</sup>. It is found that process-related exposures are as follows:

Process	Exposure (mg/m <sup>3</sup> )	Duration (mins)
General duties/background	5	420
Loading n-Butyl acrylate into system	40	5
Cleanup	60	10

### Calculating the 8 hour TWA:

$$= \frac{5 \times 420 + 40 \times 5 + 60 \times 10}{480}$$

= 6 mg/m<sup>3</sup> which is above the ES of 5 mg/m<sup>3</sup>

When assessing these exposures individually it is tempting to first address the cleanup and then perhaps the loading of n-Butyl acrylate as these have the highest exposure concentrations. However, these are short in duration and actually add little to the overall 8 hour exposure standard. 72% of the exposure comes from general duties.

- If you were to reduce the cleanup from 60 mg/m<sup>3</sup> to 15 mg/m<sup>3</sup>, then the overall exposure is 5.1 mg/m<sup>3</sup>.
- However, if you were to reduce the general duties concentration even from 5 mg/m<sup>3</sup> to 3 mg/m<sup>3</sup> (a much smaller reduction), then the overall exposure result is 4.3 mg/m<sup>3</sup> (which is an improvement).

### Calculating the STEL:

During the loading process the exposure is 30 mg/m<sup>3</sup> for 5 minutes and 5 mg/m<sup>3</sup> for 10 minutes (5 mg/m<sup>3</sup> is the background concentration).

STEL:

$$= \frac{40 \times 5 + 5 \times 10}{15}$$

$$= 16.7 \text{ mg/m}^3$$

During the cleanup the exposure is 60 mg/m<sup>3</sup> for 10 minutes and 5 mg/m<sup>3</sup> for 5 minutes (5 mg/m<sup>3</sup> is the background concentration).

STEL:

$$= \frac{60 \times 10 + 5 \times 5}{15}$$

$$= 41.7 \text{ mg/m}^3$$

Therefore controls are necessary during the cleanup process as well.

### 3.4.4 In-house Standards

Companies may choose to have their own in-house standards of what they are willing to accept for adequate control. This is usually limited to the larger companies, and often in international companies where it is often easier to have one set of standards to use company-wide.

In-house standards generally revolve around occupational exposure limits and the use of statistics to determine if the measured exposure is acceptable or not.

An example of one company's approach is:



Individual sites must assess the results of monitoring against the relevant OELs listed in company documentation and take account of the effects of extended work shifts and extended work rosters. Atmospheric contaminant monitoring results must:

- be statistically analysed to assess compliance
- take account of potential synergistic effects

Sites assess exposure to chronic agents as exceeding the OEL (or 50% of the OEL) where the upper confidence limit of the mean exposure or the Landis upper confidence limit of the Minimum Variance Unbiased Estimate (MVUE) is greater than the OEL (or 50% of the OEL).

#### **3.4.5 Biological Exposure Standards**

Biological monitoring is recommended for a limited number of substances to determine the exposure from all sources, including dermal (skin), ingestion or non-occupational exposure. If a substance has a Biological Exposure Index (BEI®), it may be appropriate to conduct biological monitoring to ensure adequate control of the substance.

Most BEIs® are based on a direct correlation with the TLV® (ie: the concentration of the determinant that can be expected when the airborne concentration is at the TLV®) with an assumption that there is no exposure by skin absorption or ingestion. Therefore if there has been exposure by skin absorption or ingestion, the result will be higher than expected.

Correct application of BEIs® requires significant knowledge of the accompanying documentation and may be valuable in evaluating what exposure has actually occurred in an incident. Employee resistance may be encountered with this type of monitoring as many BEIs® require the use of invasive collection techniques, such as blood and urine samples.

### **3.4.6 Situations Where no Exposure Limits are Available**

If a substance has been assigned a credible occupational exposure limit, controls should be designed to ensure that the limit is not exceeded. However, there are situations where either a legal or in-house limit is not readily available or exposure data for comparison with the limit cannot be obtained. In such cases it may be possible to use a control banding approach. The use of this technique is discussed in Section 3.7.

However, with complex mixtures of contaminants and process generated fumes and gases it may be difficult to specify clear guidelines for designers to work to. In such cases professional judgements based on observations and experience may be the only approach possible.

## **3.5 DECIDING ON CONTROL OPTIONS**

When starting to consider control options it is useful to investigate whether experience for other similar processes can be applied. Also, information and guidance on control may be available from various sources, particularly for common processes. Suppliers of raw materials or process equipment or industry associations may have experience and guidance. Similar processes within the company or similar industries can also be used to assist in developing control strategies. Increasingly advice on control is also likely to be available from suppliers under regulations such as [REACH](#) in the European Union. Reference material can certainly help in devising control strategies; however, every workplace and task can be different and it is essential to observe each situation and ensure the control measures are appropriate and specific to those particular circumstances.

The hierarchy of control is a useful tool which can help the project team to determine what controls could be implemented on a particular process. However, remember that several layers of measures may be needed to achieve effective control. It is rare that one control measure on its own will reduce risk to an acceptable level. So a combination of engineering and administrative controls, together with the use of personal protective equipment for specific operations or where there is a risk of contamination, is likely to be needed.

There will be several factors influencing the choice of controls other than their effectiveness at controlling exposure. These will include the practicability of installing measures on a process, ergonomic considerations and cost. The controls must be practicable and cost effective.

It should also be remembered that solving one health and safety problem can introduce another (eg: isolators can introduce ergonomic problems if poorly designed; local exhaust ventilation systems can be noisy, and may introduce problems associated with explosions when exhausting flammable gases or combustible dusts). So it is important to ensure that the introduction of measures to control exposure to hazardous substances does not increase the overall risk to health and safety.

Ideally all potential sources of exposure should be controlled, however there is often a finite budget and therefore the most effective controls are the most beneficial to implement first. In general, the simpler the control strategy the more effective it will be over the longer term.

Initially the question should be asked as to whether it is possible to eliminate the problem altogether by changes to substance, its physical form or changes to the process or the way the individual interacts with the process. In practice this can be difficult to achieve so options for enclosure may need to be considered – completely or partially enclosing the sources of emission so they are contained and cannot come into contact with the workers. If total enclosure is not possible, consideration can be given to whether it is feasible to construct a complete enclosure with small parts removed to enable access or operation – a partial enclosure with ventilation.

The next option is local exhaust ventilation – which is often less effective than most think. It is often best to start with the concept of trying to enclose and designing the hood as a partial enclosure. During the design of these care needs to be taken to observe the flow of the contaminant.

Also other factors that can affect the efficiency of ventilation – the aerodynamics of the hood design, cross drafts from doors and windows that can disrupt air flow patterns need to be considered. Even movement of the worker and their position can materially affect the air flows in the vicinity of the hood and impact control effectiveness.

Procedural controls should also be considered. For example, procedures to place space between the worker and the source of emissions. Means of cleaning and maintenance need particular attention as these can often cause higher than normal exposure. Contaminants can accumulate in confined spaces and opening those enclosures or processes can create exposures to a range of substances. Process conditions can also modify the physical or chemical form – cleaning and maintenance can therefore expose workers to modified or different risks to those during normal operations.

Personal protective equipment – PPE – is the last option - the last barrier. The focus here is on creating a worker that is safe rather than a working environment that is safe – and hence it is one of the least preferred options. Unfortunately, it is often used incorrectly as the first line of defence in a mistaken understanding of its cost and effectiveness.

### **3.6 DECIDING ON MANAGEMENT MEASURES**

Control measures will only be effective if they are properly managed. So, once the controls needed have been decided upon, consideration needs to be given to the management measures that will need to be introduced to ensure that the controls remain effective. As previously discussed these may include:

- Supervision
- Maintenance of engineering controls continue to operate effectively
- Testing of controls
- Air monitoring and health surveillance
- Information, instruction and training
- Emergency procedures
- Good housekeeping practices

### 3.7 CONTROL BANDING

Control banding offers a simplified approach to selecting appropriate control measures. It classifies controls into a few categories, or bands, based on how far they reduce exposure. The greater the potential for harm, the greater the degree of control needed to manage the situation and make the risk “acceptable”.

Control banding depends on being able to specify the performance required of the system. Where Occupational Exposure Limits (OELs) are available, they can be used to define the range of exposures that is acceptable. This is called “Performance-Based OEL Banding”. (Nauman 1996)

Often though, control banding is used when no OELs have been set. This can be done by “Hazard Banding”. The concept was developed in the late 1980’s by occupational health experts in the pharmaceutical industry. This industry invents large numbers of new chemical compounds which initially have only limited hazard data available. The experts reasoned that such compounds could be classified by their likely toxicity and by the need to restrict exposure as a precaution. Hazard banding is a systematic method of assigning compounds to a particular Occupational Hazard Category (OHC) based on the potency, pharmacological and toxicological effects of the active pharmaceutical ingredient. Each category corresponds to a range of exposures that is likely to be “safe” for that material. Different companies have different schemes, but for example, a low hazard material might be assigned to OHC-1 which typically requires exposure to be restricted to less than 5 mg/m<sup>3</sup>. In contrast, a very potent drug might be assigned to OHC-5, which might require exposure to be controlled to less than 1 µg /m<sup>3</sup>.

Once an OHC has been assigned, the potential for exposure is assessed, taking into account exposure factors such as the nature of the process, the volume of material handled, its physical form and its dustiness. An Exposure Control Approach (ECA) is then chosen to achieve the desired performance specification.

In a typical scheme, the ECAs are supported by extensive information on how to select the appropriate engineering and administrative measures.

Table 3.1 illustrates the classifications used by one pharmaceutical company.

**Table 3.1 - An example of a Pharmaceuticals Banding System**

OHC	Performance Band ( $\mu\text{g}/\text{m}^3$ )	Exposure Assessment	ECA	Summary Description of Control Options
1	>1000 - $\leq$ 5000		A	Room ventilation
2	>100 - $\leq$ 1000		B	Local extract ventilation
3	>10 - $\leq$ 100		C	Partial enclosure
4	>1 - $\leq$ 10		D	Enclosed processing and isolation
5	$\leq$ 1		E	Enclosed processing plus additional containment

(Source: GlaxoSmithKline – reproduced with permission)

In recent years the concept of “control banding” has been applied to assist small to medium enterprises who do not usually have access to risk assessment expertise. It is intended to simplify risk management by providing an easy-to-understand, practical approach to controlling hazardous exposures at work.

Control Banding has achieved significant prominence, especially in Europe. The most developed model for control banding is “COSHH Essentials”, which has been established by the Health & Safety Executive (HSE) of the United Kingdom and is named after the UK’s COSHH (Control of Substances Hazardous to Health) Regulations. [For a very good description of the evolution of Control Banding, see Zalk 2008.]

COSHH Essentials is a control banding scheme that is available as a free online tool at [www.coshh-essentials.org.uk](http://www.coshh-essentials.org.uk) (accessed August 2009). It is set out in a simple step-by-step approach which assists businesses to assess the risk, implement any measures needed to control exposure and establish good working practices.

A complete example is available to gain a better understanding of the requirements and outcomes. Each step in the guideline also refers people to additional information that may be used to complete the step appropriately.

Information that is required to complete COSHH Essentials is:

- The type of task eg: shovelling, drilling, filling a container
- The hazard classification (using the risk and safety phrases from the relevant Material Safety Data Sheet (MSDS))
- The volatility or dustiness (which is explained in the guidance material)
- The approximate amount used, in mg, litres or kg

The online tool then identifies the type of controls required, produces advice on how to implement the controls and provides written evidence of guidance and the documentation.

COSHH Essentials has been adapted as the basis of the ILO Chemical Control Toolkit, which is published jointly by the International Labor Organisation (ILO), World Health Organisation (WHO) and United Nations Environment Programme

[http://www.ilo.org/public/english/protection/safework/ctrl\\_banding/toolkit/icct/index.htm](http://www.ilo.org/public/english/protection/safework/ctrl_banding/toolkit/icct/index.htm) (accessed August 2009).

Control Banding schemes do have a number of limitations. For example, they typically do not apply to process dusts or fumes due to the fact that the hazards of these materials are not classified by the supplier of individual chemicals. Such situations include “hot” processes like welding, open spray applications, gases, etc.

It should also be recognised that all such systems provide general guidance based on the most likely scenario and do not take account of individual process variations. Nor do they necessarily provide sufficient protection to susceptible groups (young workers and pregnant women).

Hence they do not replace the need for expert evaluation and traditional exposure assessment. While such systems are a useful tool for small businesses, assessment of a workplace by an experienced occupational hygienist may be (and in many cases is) required.

However, the schemes are evolving all the time and are becoming increasingly sophisticated. The COSHH Essentials scheme is being progressively extended by the addition of industry and task-specific guidance on many situations; see <http://www.hse.gov.uk/pubns/guidance/index.htm> (accessed August 2009). Sheets are now available for welding, metalworking fluids, silica exposures and low-level asbestos work. Particular industries such as printing have developed customised sheets for their own specialised processes.

Control banding approaches are also being developed in Belgium (REGETOX project), The Netherlands (Stoffenmanager), and Norway (KjemiRisk). The World Health Organisation is working with its Collaborating Centres to pilot control banding programmes in more than a dozen countries.

### **An example of a Control Banding System – The ILO Toolkit**

The ILO Toolkit has five (5) stages which need to be followed. These are:

Stage 1: Find the hazard classification and match it to a hazard group. For common solvents this has already been done and the information provided on the ILO website. For other substances there is a need to establish the risk phrases for the substance and then find the hazard group from the ILO website.

Stage 2: Establish the amount of substance to be used and use this to determine the scale of use from the table supplied by the ILO.



Stage 3: Establish how much of the substance will escape to the atmosphere. This is done via looking at the physical state of solids (eg: pellets – low, crystalline – medium, fine powders – high) or via comparison of the boiling point of liquids to a table provided by the ILO.

Stage 4: Find the control approach by using a selection guide that has been prepared by the ILO.

Stage 5: Find the task-specific control guidance sheet(s) from a table which links the task description and the control approach.

Once the appropriate control approach has been determined it needs to be implemented and maintained.

The stages are explained in more detail below.

**Stage 1: Using the following, find the hazard classification and match it to a hazard group**

Hazard Group	EU R-Phrases	GHS hazard classification (class/level)
<b>A</b>	R36, R38, R65, R66 All dusts and vapours not allocated to another band	Acute toxicity (lethality), any route, class 5 Skin irritancy class 2 or 3 Eye irritancy class 2 All dusts and vapours not allocated to another band
<b>B</b>	R20/21/22, R40/20/21/22, R33, R67	Acute toxicity (lethality), any route, class 4 Acute toxicity (systemic), any route, class 2
<b>C</b>	R23/24/25, R34, R35, R37, R39/23/24/25, R41, R43, R48/20/21/22	Acute toxicity (lethality), any route, class 3 Acute toxicity (systemic), any route, class 1 Corrosivity, subclass 1A, 1B or 1C Eye irritancy class 1 Respiratory system irritancy (GHS criteria to be agreed) Skin sensitisation Repeated exposure toxicity, any route, class 2

<b>D</b>	R48/23/24/25, R26/27/28, R39/26/27/28, R40 Carc. Cat. 3, R60, R61, R62, R63, R64	Acute toxicity (lethality), any route, class 1 or 2 Carcinogenicity class 2 Repeated exposure toxicity, any route, class 1 Reproductive toxicity class 1 or 2
<b>E</b>	R42, R45, R46, R49, R68	Mutagenicity class 1 or 2 Carcinogenicity class 1 Respiratory sensitisation
<b>S</b> <b>skin and eye contact</b>	R21, R24, R27, R34, R35, R36, R38, R39/24, R39/27, R40/21, R41, R43, R48/21, R48/24, R66	Acute toxicity (lethality), dermal only, class 1, 2, 3 or 4 Acute toxicity (systemic), dermal only, class 1 or 2 Corrosivity, subclass 1A, 1B or 1C Skin irritation class 2 Eye irritation class 1 or 2 Skin sensitisation Repeated exposure toxicity, dermal only, class 1 or 2

(Source: ILO Toolkit)

**Stage 2: Using the following, establish the amount of substance to be used**

Quantity	Solid		Liquid	
	Weight	Typically received in	Volume	Typically received in
Small	Grams	Packets or bottles	Millilitres	Bottles
Medium	Kilograms	Kegs or drums	Litres	Drums
Large	Tonnes	Bulk	Cubic metres	Bulk

(Source: ILO Toolkit)

### Stage 3: Dusts

Using the following, establish how much of the substance will escape to the atmosphere through dust

- Low: Pellet like solids that don't break up. Little dust is seen during use e.g. PVC pellets, waxed flakes
- Medium: crystalline, granular solids. When used, dust is seen, but settles out quickly. Dust is left on surfaces after use e.g. soap powder.
- High: fine, light powders. When used, dust clouds can be seen to form and remain in the air for several minutes e.g. cement, carbon black, chalk dust.

(Source: ILO Toolkit)

### Stage 3 (continued): Vapours

Using the following, establish how much of the substance will escape to the atmosphere through volatility.

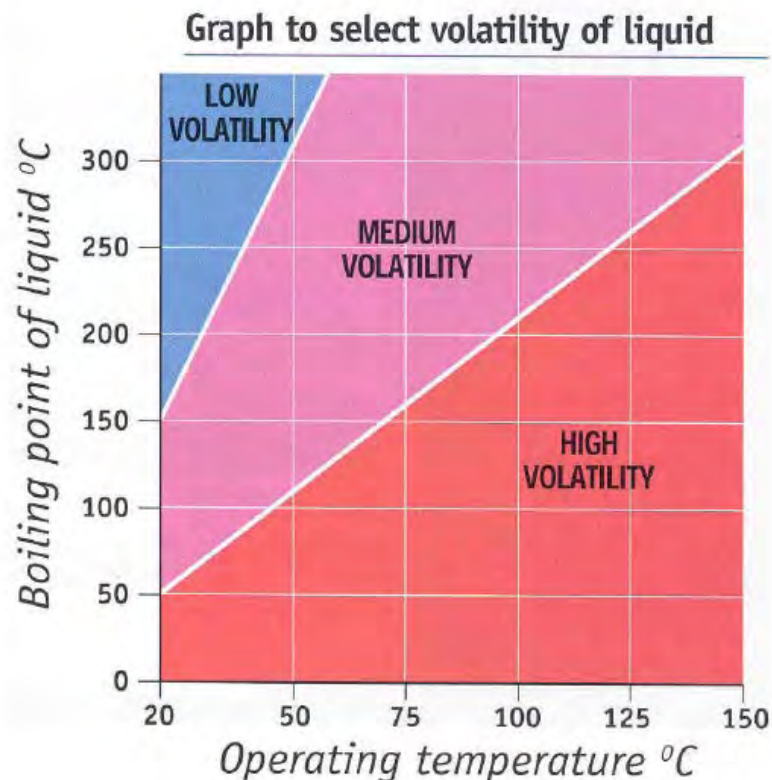

(Source: ILO Toolkit)

**Stage 4: Using the following, determine the control approach**

Amount used	Low dustiness or volatility	Medium volatility	Medium dustiness	High dustiness or volatility
<b>Hazard group A</b>				
Small	1	1	1	1
Medium	1	1	1	2
Large	1	1	2	2
<b>Hazard group B</b>				
Small	1	1	1	1
Medium	1	2	2	2
Large	1	2	3	3
<b>Hazard group C</b>				
Small	1	2	1	2
Medium	2	3	3	3
Large	2	4	4	4
<b>Hazard group D</b>				
Small	2	3	2	3
Medium	3	4	4	4
Large	3	4	4	4
<b>Hazard group E</b>				
For all hazard group E, substances, choose control approach 4				

(Source: ILO Toolkit)

**Stage 5: Using the following, find the task-specific control guidance sheet**

Task description	Task control sheet
<b>Control Approach 1</b>	
General principles	<a href="#">100</a>
Sack, bottle and drum storage	<a href="#">101</a>
Bulk storage	<a href="#">102</a>
Removing waste from air cleaning unit	<a href="#">103</a>
<b>Control Approach 2</b>	
General principles	<a href="#">200</a>
Ventilated workbench or cupboard	<a href="#">201</a>
Ventilated booth	<a href="#">202</a>
Removing waste from air cleaning unit	<a href="#">203</a>
Conveyor transfer	<a href="#">204</a>
Sack filling	<a href="#">205</a>
Sack emptying	<a href="#">206</a>
Charging reactor or mixer from sack or keg	<a href="#">207</a>
<b>Control Approach 3</b>	
General principles	<a href="#">300</a>
Glove box	<a href="#">301</a>
Removing waste from extraction unit	<a href="#">302</a>
Transferring solids	<a href="#">303</a>
High throughput sack emptying	<a href="#">304</a>
Drum filling	<a href="#">305</a>
Drum emptying	<a href="#">306</a>
IBC filling and emptying (solids)	<a href="#">307</a>
IBC filling and emptying (liquids)	<a href="#">308</a>
Tanker filling and emptying (solids)	<a href="#">309</a>
Tanker filling and emptying (liquids)	<a href="#">310</a>
Keg filling	<a href="#">311</a>
Transferring liquid by pump	<a href="#">312</a>
Filling small containers (packets and bottles)	<a href="#">313</a>
Weighing solids using a load cell	<a href="#">314</a>
Weighing liquids using a load cell	<a href="#">315</a>
Mixing solids	<a href="#">316</a>
Mixing liquids with liquids or solids	<a href="#">317</a>
Vapour degreasing bath	<a href="#">318</a>
<b>Control Approach 4</b>	
General principles	<a href="#">400</a>

#### 4. UNDERSTANDING SOURCES OF CONTAMINANTS

Before consideration of specific measures to control hazardous substances is commenced, it is important to have a good understanding of the sources of contaminants that require control.

In this regard it is important to distinguish between processes and sources. These can be stated as:

**Process** – The way airborne contaminants are generated. For example in woodworking the processes could be cutting, routing, planing or sanding.

**Source** – The point where the contaminant is generated by a process.

These concepts are illustrated in Figure 4.1 which demonstrates the process, source and contaminant clouds arising from an angle grinder.

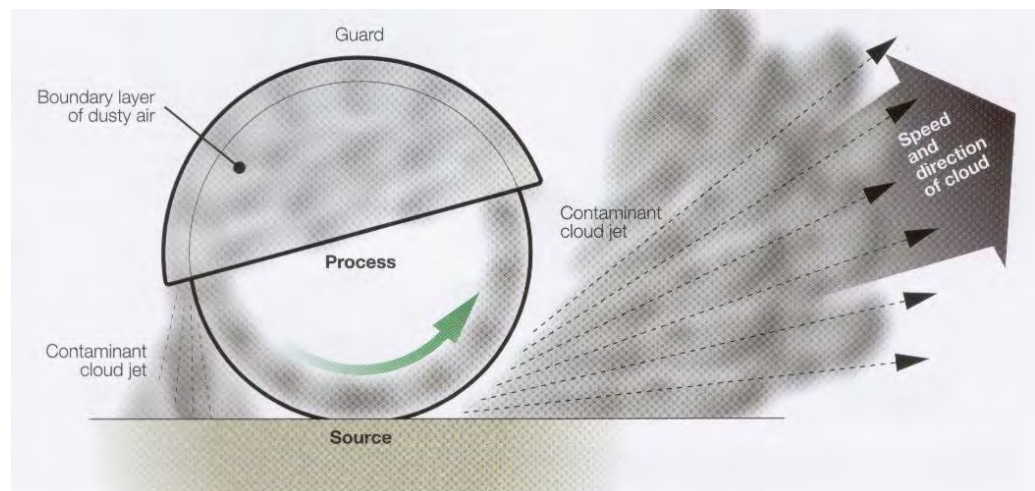

(Source: HSE – reproduced with permission)

**Figure 4.1**

Thus, if we understand the process we should understand the creation of contaminant sources and therefore suggest measures to modify the process to reduce the number or size of sources and contaminant clouds.

The HSE (2008) suggest sources fall into four general types; these being:

1. Buoyant – eg: hot fumes
2. Injected into moving air – eg: by a spray gun

3. Dispersed into workplace – eg: draughts
4. Directional – eg: power tools

The HSE (2008) indicate that there are at least five sub groups of directional sources, including:

- Explosive release
- Progressive release
- Doughnut-shaped release around a rotating disc
- Broad fan-shaped release from a rotating disc
- Narrow jet release from cutting trench

When considering the strength of a source it can be defined in terms of the area from which the contaminant originates, the flow of the contaminant away from the source and the atmospheric concentration of the contaminant.

As the contaminant moves away from its source the more dispersed it becomes and thus much larger. While dilution reduces the contaminant concentration within the atmosphere, it is always more effective to control the contaminant close to its source. The reasons for this are:

- The volume of contaminant in the atmosphere is smaller and thus easier to control.
- Collection of the whole contaminant cloud is more likely.
- Operators are less likely to be exposed.

Consequently, the approach to controlling a particular hazardous substance is determined to a large degree by a combination of factors including:

- Source strength
- Contaminant cloud volume, shape, speed and direction of movement
- Contaminant concentration

Notwithstanding the above, it is important to understand that a single process can create several sources of contaminants at different stages. An example of this can be observed in Figure 4.1 where three contaminant clouds are clearly defined. Others that may arise include re-suspension of settled dust in the atmosphere and dust deposited on the protective clothing of the operator.

It cannot be overstated that the control of hazardous substances requires examination of all the sources of contaminant release within a process.

The HSE (2008) has prepared a list of common process and sources which is reproduced in Table 4.1.

**Table 4.1 – Common Processes & Sources**

Process	Examples	Creation Mechanism(s) & Source Description	Form	Possible Controls
Rotating tools and parts	Orbital, belt and disc sanders. Disc cutters. Circular saws and routers. Lathes. Drills. Abrasive wheels.	Rotating motion creates a fan effect.  The source created can be a jet (eg: angle grinder with guard) or a doughnut-shaped cloud (eg: disc sander).	Dust, mist.	<ul style="list-style-type: none"> <li>• Enclosure.</li> <li>• Strip off the 'boundary layer' of dust-laden air moving with the rotating disc.</li> <li>• Fit a receiving hood to the guard.</li> <li>• Use LVHV (low volume high velocity extraction).</li> </ul> Other controls, eg: <ul style="list-style-type: none"> <li>• Water suppression.</li> </ul>
Hot (and cold) processes	Furnaces and casting. Soldering and brazing. Welding. Using liquid nitrogen.	Hot sources – fume rises, expands, cools and mixes with the room air.  Cold sources – the contaminant sinks.	Fume, vapour, gas.	<ul style="list-style-type: none"> <li>• Enclose.</li> <li>• Receive the hot fume or cold contaminant cloud in a hood.</li> </ul> Other controls, eg: <ul style="list-style-type: none"> <li>• Control temperatures to reduce fume.</li> </ul>



Process	Examples	Creation Mechanism(s) & Source Description	Form	Possible Controls
Free-falling, solids, liquids and powders	Falling liquid, powder or solid material. Conveyor transfer of powders/solids.	Falling material induces a downward flow of air. If the material is a powder, there will be some shearing of fine particle-laden air at the edges of the stream. The entrained air and dust may 'splash'.	Dust, vapour.	<ul style="list-style-type: none"> <li>• Reduce the fall distance.</li> <li>• Enclose.</li> <li>• Seal gaps in conveyors.</li> <li>• Partially enclose transfer points.</li> </ul>
Displacement	Liquid, powder and granular solid transfer into a container.	Materials displace their own volume of contaminated air from the container. If they have fallen from a height, the induced airflow will displace even more air from the container.	Dust, vapour.	<ul style="list-style-type: none"> <li>• Partial enclosure.</li> <li>• Reduce the fall distance.</li> <li>• Minimise the container's open area.</li> <li>• Make the container a receiving hood.</li> </ul> <p>Other controls, eg:</p> <ul style="list-style-type: none"> <li>• Pump liquids through pipes extending to the bottom of the container.</li> <li>• Use a vapour recovery system.</li> </ul>
Spraying and blasting	Paint spraying. Abrasive blasting.	Compressed air pressure produces a jet that induces further air movement. The contaminant cloud is cone-shaped. A paint spray gun can emit air at more than 100 m/s, extending more than 12 m.	Mist, vapour, dust.	<ul style="list-style-type: none"> <li>• Reduce air pressure, eg: HVLP (high volume low pressure) spray gun.</li> <li>• Full, room or part enclosure.</li> </ul> <p>Other controls, eg: use:</p> <ul style="list-style-type: none"> <li>• Water-borne abrasive.</li> <li>• Abrasive shot, not mineral.</li> <li>• Electrostatic methods for surface coating.</li> </ul>

Process	Examples	Creation Mechanism(s) & Source Description	Form	Possible Controls
Fracturing solids	Rock crushing. Hardcore – concrete crushing. Splitting (eg: slate making).	Brittle fracture creates 'explosive' release of a dust cloud. Material movement may then create airflow or assist the dust cloud growth.	Dust.	<ul style="list-style-type: none"> <li>• Full or partial enclosure.</li> <li>• Receiving, push-pull or capturing hood.</li> </ul> Other controls, eg: <ul style="list-style-type: none"> <li>• Water suppression;</li> <li>• Supplementary RPE often needed.</li> </ul>
Impact and vibration	Dumping dusty bags on a surface. Machinery vibration re-suspending settled dust.	Shock of the physical impact or vibration creates a dust cloud. Dust-contaminated clothing can also create a dust cloud. Settled dust can re-suspend in the air.	Dust.	<ul style="list-style-type: none"> <li>• Partial enclosure.</li> </ul> Other controls, eg: <ul style="list-style-type: none"> <li>• Control spillage.</li> <li>• Vacuum system for cleaning.</li> <li>• Minimise impact and vibration.</li> </ul>
Compaction	Waste crushing.	Compaction creates a dust cloud. Material movement may then create airflow.	Dust.	<ul style="list-style-type: none"> <li>• Extract compactor in its own enclosure.</li> <li>• Partial enclosure.</li> </ul>
Handling	Sorting.	Recycling waste.	Dust, mist.	<ul style="list-style-type: none"> <li>• Local air displacement.</li> </ul>
Machining	Milling. Turning.	Cooling fluid on rotating or reciprocating movement.	Mist.	<ul style="list-style-type: none"> <li>• Full enclosure.</li> <li>• Partial enclosure.</li> </ul> Other controls, eg: <ul style="list-style-type: none"> <li>• Cold working.</li> <li>• Increase fluid flow to increase cooling.</li> </ul>
Abrasion	Sanding. Grinding. Polishing. Fettling.	Mechanical removal of surfaces create airborne dust.	Dust.	<ul style="list-style-type: none"> <li>• Capturing hood, eg: draught or back-draught table.</li> <li>• Partial enclosure, eg: booth.</li> <li>• LVHV systems.</li> </ul> Other controls, eg: <ul style="list-style-type: none"> <li>• Water suppression.</li> </ul>

Process	Examples	Creation Mechanism(s) & Source Description	Form	Possible Controls
Sweeping	Dust and particulate matter.	Re-suspending settled dust – a dust cloud moving in the direction of brushing.	Dust.	Other controls, eg: <ul style="list-style-type: none"> <li>• Minimise dust leaks.</li> <li>• Vacuum system.</li> <li>• Wet cleaning.</li> </ul>

(Source: HSE – reproduced with permission)

The above is by no means an absolute list but it does serve to provide guidance for common processes. What must be understood is that for every process there is a need to investigate and evaluate the significance of every contaminant source before considering which control strategies are appropriate.

It must be remembered that exposure to hazardous substances can occur by routes other than inhalation. All potential exposure routes need to be considered and controlled where necessary.

Often neglected, skin adsorption is also an important route of entry. Although the skin is an effective barrier many chemicals, including a large number of common industrial solvents, when in contact with it for long enough, can pass through the skin and enter the bloodstream. Many chemicals also have a direct effect on the skin, causing irritation, chemical burns or leading to dermatitis. The rate of absorption then depends on the surface area covered and whether the skin has been damaged or not. Skin damage increases absorption. Many solvents may be absorbed through the skin as well as some more toxic materials eg: Phenol.

Skin exposure can occur in a number of ways

- **Immersion** of the fingers, hands, legs or other parts of the body into the chemicals
- **Direct contact** of chemicals with the skin (usually the hands) when handling contaminated tools etc
- **Splashes**

- **Deposition** of dusts or mists on the skin

Ingestion is the least common route of entry in industry. Very few people deliberately swallow chemical substances at work. However accidental ingestion can sometimes occur, for example from eating, drinking or smoking with contaminated hands.

Injection or skin penetration may also occur in some situations. For example, “needlestick injuries” (accidental injection) may occur when medical staff use syringes when treating their patients. It can also be a risk for laboratory personnel who use syringes to inject substances into analytical equipment. Another potential source of causing forced penetration of substances into the skin can be the improper use of compressed air for removing contaminants from clothing and/or skin, and high pressure water jetting without suitable PPE.

## **5. PROCESS DESIGN AND PRINCIPLES**

### **5.1 GENERAL DESIGN OF EQUIPMENT AND WORKPLACE LAYOUT**

The general design of equipment in regards to controlling exposure to contaminants should be considered at the design stage. It is important to not only consider the equipment being used, but also where it will be located in relation to people, other equipment and processes, openings and doorways and other facilities.

The location of any process that can emit contaminants hazardous to health should be kept separate from meal rooms, offices, first aid rooms and other areas where workers or the community can potentially be exposed at times and places where it is not considered.

Processes should ideally not be adjacent to other processes that may affect the overall exposure of workers. If possible, two welders should not be placed side by side, as a welder will be exposed to their own fumes and gases, and also the fumes and gases from the second welder. Exposure to the second welders' contaminants in some cases may be even worse as it can occur when they remove their own face shields or other protective equipment during periods when they are not welding. Most welding fume from the source travels outside the face shield of the welder which acts as a control and can reduce their exposure.

Process should be kept away from doors, windows and walkways to prevent draughts affecting the performance of extraction systems. If there is draft around these systems, it can cause short circuiting and the contaminant is not removed by the extraction system, but rather is pushed further out into the workspace, with potentially clean air being extracted.

When using ventilation systems it is important to consider where the ventilation will discharge to ensure the contaminant is not re-entrained into the building. If this occurs, room changes of air are not being replaced with clean air, but air that already holds some contaminants.

It is also important to consider where outside air comes from to ensure that contaminants are not introduced from another facilities process, ie: a building's ventilation intake air is not good if it originates in a carpark at the height of a vehicle's exhaust as it already contains contaminants from the fume.

Automation of processes and the use of robotics can have many benefits. There is generally an increased throughput of the product, the product should be reliably accurate each time, and there are reduced cycle times. There are further benefits when considering exposure to chemicals, providing the contaminants coming off the process are adequately controlled and handled. If a process is automated, exposure to chemicals at the source should essentially be eliminated, with the exception of maintenance and any 'supervision' or quality checking required. Exposure to secondary contamination also has the potential to be negligible providing adequate controls are provided at the source in the area of automation. The most used control in this instance is likely to be ventilation, and particularly extraction, of which there is more explanation and detail in Section 6.

An example of automation where there are significant benefits to the workers is welding.

The advantages of automated welding are numerous in regards to quality and quantity including:

- Reducing the need for highly skilled welders,
- Savings in the costs of consumables, time and quality control
- Higher current can be used allowing better fusion
- Welding is continuous from the beginning to the end of the seam, thereby eliminating areas of weakness

There are different levels of automation, and obviously it is not applicable to all welding operations, particularly maintenance, which is typically where a lot of exposure occurs, however, it does create less exposure in instances where it can be used.

There are many health benefits when reducing the amount of exposure welders receive. The respiratory system is the primary target of injury for welders. Metal fume fever and pneumonitis are the most common acute respiratory diseases associated with welding as a result of short-term exposures to high concentrations of fumes and gases. Less commonly chronic respiratory diseases such as cancer, pneumoconiosis and bronchitis have been observed among workers exposed to certain welding fumes and gases. In addition to respiratory diseases, cancers of the kidney, and other urinary tract organs and the larynx have been described in some workers.

The emptying of small bags of product is also an area that can be automated or semi automated, this is particularly useful and beneficial for products that are very dusty, and/or contain high silica. Instead of having a worker cut open and dump bags into a container, an automated system can cut open the bag, with extraction available to remove any dust. Airborne dust can be drawn from an operator's atmosphere into cartridge filters that are automatically cleaned, removing the dust into a hopper for cleaning. Often workers will still have to remove bags, and this must be done in a way to reduce exposure to dust.

The cleaning and maintenance of these systems, as with all controls and maintenance of any process, needs to be assessed and addressed independently to all other processes. It is important that maintenance personnel and cleaners are not forgotten when control of exposure is considered.

## 5.2 PREVENTION BY ELIMINATION & SUBSTITUTION

Prevention, by either elimination, substitution or source modification, is the preferred method when working with potential exposures. If enough thought and planning goes into a process prior to the process implementation, it is possible to prevent exposures entirely.

Elimination, changing a process or substance completely, resulting in the hazard not existing is the next best control option. This is typically a high cost strategic business decision that may result in completely closing down a process. It is a very simple decision if the process can be closed down with no adverse effects to industry, workers or supply, however this outcome is rare.

Substitution by a less hazardous substance or process is the next best option but needs care to ensure that the substitute is actually less of a risk in practice. There are a number of cases where substitutes have subsequently been found to be more hazardous than the original. As previously discussed, the source is the origin of the contaminant and if the contaminant is controlled at the origin, there is less chance of people being exposed to concentrations of contaminants that are harmful to health.

Substitution can be a simple and effective control, however, it is simple only if you have the right substance to substitute with the hazardous chemical. It is not necessarily simple to find the substitute that has the same characteristics of the hazardous substance, will produce the same or equivalent outcome and where it is known for sure that the risk is lower.

When introducing a substitute chemical, care needs to be taken to ensure that a hazardous chemical is not substituted by one where the hazards are not yet fully understood or which may produce different risks in use. The example below of glutaraldehyde illustrates some of the challenges in using substitution as a control. Almost inevitably, substitution of one hazardous substance with another will still require other control measures to address any residual risks from the substitute



There are a number of ways the source can be controlled when using substitution source control.

- Removing a more hazardous process and replacing it with a less hazardous one
- Removing a more hazardous chemical and replacing it with a less hazardous chemical

A well known example is the substitution of asbestos products with other, safer synthetic substitutes. Asbestos causes cancer and also mesothelioma.

- It has been replaced with safer products such as rock wool and glass wool.

Other examples include:

- Replacement of petroleum naphtha with carbon tetrachloride for dry cleaning; carbon tetrachloride also has hazardous properties and was then replaced by perchlorethylene
- Lead free paints and solders are available rather than products with lead in them. Lead can cause adverse health effects, and most developed countries have used lead free paint for decades. However, many products are exported from China including 70-80% of children's toys, and in August 2007, there was substantial community concern and recalling of children's toys, when it was determined that they were painted with leaded paint. It should not be taken for granted that common hazardous substances are not used, particularly in the materials or products are sourced from countries with lower levels of product regulation and quality control
- Sandstone grinding wheels that contain high amounts of silica can be substituted for synthetic grinding wheels made of products such as aluminium oxide
- Propylene glycol can replace the toxic ethylene glycol in cooling fluids

- Anhydrous ammonia (100% ammonia in liquid form) has been used as a feedstock in the processing of manganese ore. Replacing this with aqueous ammonia (ammonium hydroxide solution) results in less of a hazard in the event of a leak

When substituting chemicals, it must be remembered that the behaviour of volatile chemicals (solvents) is very different to those of non-volatile chemicals (solid metal, powders). Both the solvent and non-volatile chemical can have a similar toxicity, however the vapour pressure of volatile chemicals is sufficient for them to become a hazard while passive in the workplace, whereas non-volatile chemicals can 'sit' passively without becoming airborne.

A case study involving glutaraldehyde highlights these points.

Glutaraldehyde replaced formaldehyde as a hospital disinfectant. Formaldehyde is highly toxic, irritating and is a carcinogenic chemical. However, soon after the introduction of glutaraldehyde, serious health effects were reported from its use. Glutaraldehyde is used for a number of applications including as a cold sterilant in the health care industry. It is used to disinfect equipment that cannot be heat sterilized such as dialysis instruments, surgical instruments, suction bottles, bronchoscopes, endoscopes, and ear, nose, and throat instruments.

It is also used for the following purposes:

- As a tissue fixative in histology and pathology labs
- As a hardening agent in the development of X-rays
- In embalming solutions
- In the preparation of grafts and bioprotheses
- In various clinical applications

Charney (1991) provides an outline of the toxicities of glutaraldehyde and some potential control strategies.

The chemical is most often used in a diluted form with solutions ranging from 1% to 50% glutaraldehyde in water. Workers can be exposed to glutaraldehyde through inhalation or skin contact. Health effects that may occur as a result of exposure to glutaraldehyde include but are not limited to the following:

- Short term (acute) effects: Contact with glutaraldehyde liquid and vapour can severely irritate the eyes, and at higher concentrations burns the skin. Breathing glutaraldehyde can irritate the nose, throat, and respiratory tract, causing coughing and wheezing, nausea, headaches, drowsiness, nosebleeds, and dizziness
- Long-term (chronic) effects: Glutaraldehyde is a sensitiser. This means some workers will become very sensitive to glutaraldehyde and have strong reactions if they are exposed to even small amounts. Workers may get sudden asthma attacks with difficulty breathing, wheezing, coughing, and tightness in the chest. Prolonged exposure can cause a skin allergy and chronic eczema, and afterwards, exposure to small amounts produces severe itching and skin rashes. It has been implicated as a possible cause of occupational asthma

Possible controls include:

Limit exposure to glutaraldehyde through work practice, engineering controls and personal protective equipment (PPE) including:

- Make sure that rooms in which glutaraldehyde is to be used are well ventilated and large enough to ensure adequate dilution of vapour, with a minimum air exchange rate of 10 air changes per hour
  - Ideally, install local exhaust ventilation such as properly functioning laboratory fume hoods (capture velocity of at least  $0.5 \text{ ms}^{-1}$ ) to control vapour
  - Keep glutaraldehyde baths under a fume hood where possible
- Use only enough glutaraldehyde to perform the required disinfecting procedure

- Store glutaraldehyde in closed containers in well ventilated areas. Post signs to remind staff to replace lids after using product
- Use specially-designed, mobile, compact, disinfectant soaking stations to facilitate sterilisation of heat sensitive equipment such as endoscopes. These soaking stations provide an enclosed area for sterilising trays, and remove fumes from glutaraldehyde and other disinfectants
- Use appropriate PPE including:
  - Use gloves that are impervious to glutaraldehyde such as those made of Butyl Rubber, Nitrile, and Viton®, which have been shown to provide full shift protection from glutaraldehyde
  - For shorter exposures, use gloves made of polyethylene. Do not use Neoprene and PVC gloves because they do not provide adequate protection against glutaraldehyde and may actually absorb it
  - Do not use latex surgical exam gloves for skin protection against glutaraldehyde, except in situations where only short-term, incidental contact is expected
  - Wear lab coats, aprons, or gowns made of appropriate materials such as polypropylene to provide additional protection
  - Wear splash-proof goggles and/or full face shields when working with glutaraldehyde to protect eyes
  - All employees who may be exposed to above the ceiling threshold limit value (TLV®) of 0.05 ppm, should use appropriate respirators for glutaraldehyde vapour during routine or emergency work
- Clean up spills immediately.
- Do not eat, drink, or smoke in any area where glutaraldehyde is handled or stored
- Use a vacuum or wet method to reduce dust while cleaning up pure glutaraldehyde. Do not dry sweep
- Use less toxic products if feasible and available, or other processes for sterilisation

- Automate the transfer of pure glutaraldehyde or pump liquid glutaraldehyde from drums or other storage containers to appropriate containers and operations, avoiding exposure to glutaraldehyde by keeping it in a contained process
- Communicate the hazard ensuring that the hazards of all chemicals are evaluated and that this information is transmitted to the employees by means of a hazards communication programme which includes, labelling, material safety data sheets, and employee training

Alternatives to glutaraldehyde are available and have largely started to be used. They maintain infection control standards and do not cause undue wear and tear on sensitive medical devices; however there are reports that some of these can also cause occupational illness including occupational asthma. OPA (ortho-phthalaldehyde) is one alternative, however it appears that it may have similar hazards to glutaraldehyde, however, the product used is more dilute than glutaraldehyde and it seems it is less likely to vapourise. This may offer some protection through lowering exposure levels. However, contact through the skin or during spills could lead to high exposure levels that may cause serious health problems including asthma. OPA does have a strong staining effect on the skin, which should encourage people to take care when using it.

If a product cannot be substituted, then it may be possible to substitute the process, ie: reduce the hazard at the process by changing the way it is done.

- Replace dry sweeping using a broom with an appropriate vacuum or “wet method” to control dust and reduce the inhalation hazard. Wet methods involve spraying water over dusty surfaces to keep the dust levels down; or mixing materials with water to prevent dust from being created. (An appropriate vacuum means one with a HEPA filter in it or something similar, they are usually dedicated to particularly toxic materials like asbestos or lead)
- Use electric motors rather than diesel motors to reduce the gases and particulates emitted from the exhaust

- Use airless paint spraying, dip tank or brush application of paint to reduce the hazard of overspray inhalation when compressed air spray painting

The physical form of a substance may be altered to reduce an inhalation hazard, ie: substitution of pellets, flakes or granules may mean less dust in air.

Prior to making substitutions there are a number of factors that must be considered:

- Research and ensure that one hazard is not being exchanged for another, particularly a more serious one
- Understand all of the hazards (health, fire, corrosivity, chemical reactivity etc) of the potential substitute before making any changes
- Evaluate and compare the hazards of the different materials
- Ensure that the substitute can do the job as effectively as the original product
- Ask suppliers and other businesses with similar processes about safer substitutes
- Consider all of the pros and cons of all substitutes. Determine if changes in the work process, equipment, ventilation, PPE or disposal will also be required
- If a substitute is determined, all those involved and impacted by the substitution will need training
- Although some substitutes may appear more costly in the first instance, they may actually save money if they are safer to use. Additional savings may result from reduced requirement for ventilation, engineering controls and PPE

Understanding basic chemistry assists with the substitution of chemicals. The volatility and relation to water of chemicals plays an important role in determining its suitability or otherwise as a substitute chemical.

Non-volatile, volatile, aqueous, semiaqueous and organic solvents are five categories of chemicals that can replace other chemicals to become a less hazardous alternative.

**a) Volatile and Non-Volatile Chemicals**

Popendorf (2006) compares volatile chemicals and non-volatile chemicals and provides a comprehensive summary illustrating how important the physical nature of a chemical hazard is when considering control approaches.

**b) Volatile Materials**

Volatile chemicals are those chemicals which evaporate quickly. Therefore, volatile substances create an airborne hazard when a liquid is exposed to air. Volatile materials include liquefied gases, liquids including solvents, molten metals and aqueous mixtures with volatile constituents. The health effects of volatile materials can be varied. Routes of entry are predominantly by inhalation. With substances, such as volatile solvents, there can also be skin exposure or absorption through the skin. However, due to their volatility, the amount of time they are on the skin may be limited due to evaporation. They will also not remain for long on a contaminated surface unless it is absorbent.

Substituting a volatile chemical with a different volatile chemical can occur but the evaporation rate, vapour pressure and toxicity of the 'new' chemical must all be considered.

**c) Non-Volatile Materials**

Non-volatile chemicals do not evaporate easily and include solid metals, powders, dusts, pastes and low volatility liquids. Generally non volatile chemicals can not become airborne unless an external force causes it. Due to this there is a greater risk of skin exposure and ingestion. They can remain on contaminated surfaces of tools, buildings, or anywhere else they can settle until the area is cleaned or removed. To this end they can also be relocated if moving contaminated packages.

Therefore if replacing a volatile chemical with a non-volatile chemical, there needs to be an understanding if the route of exposure has changed from inhalation to, say dermal.

Using the least toxic non-volatile chemical is often beneficial to worker protection.

**d) Aqueous Solvents**

Organic solvents can be replaced in many instances by aqueous solvents ie the solvent is water. Additives may be added to the water to enable it to clean and degrease, including surfactants, deflocculants, saponifiers, alkalis and sequestering agents, and these must be considered individually on their own merits with regard to health effects. Contamination of the aqueous solutions must also be considered, particularly in relation to hazardous products that have been cleaned off plant equipment that has previously used the solvent, and particularly from microbial growth.

Some plant equipment may not tolerate water, and a full understanding of the process and components involved is required before deciding on an aqueous solvent over an organic solvent.

**e) Semiaqueous Solvents**

Semiaqueous solvents also consist of surfactants and water, the main chemical difference between aqueous and semiaqueous is the surfactant type. Surfactants lower the surface and interfacial tension of the water, allowing it to penetrate smaller spaces, move under the contaminant and actually lift it off. Some of the surfactants will mix with the water, and others won't. The individual attributes and their individual incompatibilities need to be understood before selecting a semiaqueous solvent. These can be a cheaper alternative than aqueous solvents.



#### f) **Organic Solvents**

An organic solvent is a liquid such as methyl ethyl ketone or toluene used to dissolve paints, varnishes, grease, oil, or other hydrocarbons. Generally organic solvents may replace other organic solvent, but they are rarely used to replace aqueous or semiaqueous solutions. They are generally volatile.

Toxicity and vapour pressure both contribute to a volatile chemical's intrinsic hazard as a vapour, however, toxicity and volatility are not related to each other. It is not a correct assumption that a chemical with a higher exposure standard is safer than one with a lower exposure standard, nor is it correct that chemicals with a low vapour pressure are safest. There are equations available to assess the toxicity and vapour pressure when deciding which chemical is the best option. These equations are detailed and a thorough understanding is required to realise their full potential.

### **5.3 LEGISLATION AS A MEANS OF ACHIEVING CONTROL**

REACH is a new European Community Regulation on chemicals and their safe use (EC 1907/2006). It deals with the **Registration, Evaluation, Authorisation and Restriction of Chemical Substances**. (This obviously differs from the general term REACH for the control of hazards – **Recognition, Evaluation and Control of Hazards**). The new law entered into force on 1 June 2007 and replaces 40 different chemical laws with one overarching EU wide system.

The aim of REACH is to improve the protection of human health and the environment through the better and earlier identification of the intrinsic properties of chemical substances. The benefits of the REACH will come gradually as more substances are phased into REACH.

The REACH Regulation gives greater responsibility to industry to manage the risks from chemicals and to provide safety information on substances and their safe use through the supply chain.

Manufacturers and importers will be required to gather information on the properties of their chemical substances, which will allow their safe handling, and to register the information in a central database run by the European Chemicals Agency (ECHA) in Helsinki. Public databases will be available for consumers and professionals to find hazard information.

The introduction of REACH will mean that there will be increasing information available from suppliers.

## **6. VENTILATION SYSTEMS**

### **6.1 INTRODUCTION**

Industrial ventilation, can provide an effective means of controlling worker exposure to hazardous substances. For this to occur, ventilation systems need to be well designed and maintained. Unfortunately, poorly designed and maintained ventilation systems are very common. In addition, ad hoc “modifications” to the system also generally detract from performance of the system.

While systems such as those indicated above do occur in far too many workplaces, those who take time to follow the principles of good design and subsequently maintain its performance are rewarded with a much healthier workplace and thus a more productive workforce. Before starting on the design of any ventilation system it is essential to have a comprehensive risk assessment and to understand the sources of contaminants and the material in Section 4. This section aims to introduce the principles of ventilation, discuss specific types of ventilation systems and their application in the workplace.

### **6.2 TYPES OF VENTILATION SYSTEMS**

Ventilation in one of its forms has been employed to control emissions for centuries, with German scholar Georgius Agricola in 1556 describing mine ventilation as a means of controlling silicosis in mines.

As industrial development has progressed so have ventilation systems; however some basic principles apply to all systems.

In the first instance ventilation systems used in the industrial environment to control hazardous substances are of two generic types. These are:

- Supply - Used to supply clean air to a workplace
- Exhaust - Used to remove hazardous substances generated in a process so as to ensure a healthy workplace

Any complete ventilation system must consider both the supply and the exhaust functions if overall performance is to be achieved.

Supply systems generally have two purposes, ie: to create a comfortable environment by the control of factors such as temperature and humidity; and/or to replace air exhausted from the workplace.

In many cases ventilation systems are installed in a workplace to extract contaminants, however due consideration has not been given to ensuring sufficient replacement air (supply system) is available. In such cases the performance of the primary extraction system degrades, leading to potential over-exposure of employees in the workplace.

Extraction systems are generally considered as being of two distinct types. These are:

- General Ventilation Systems – Removal of contaminants in a workplace by flushing out the contaminants via the introduction of large quantities of air. Where this effect is due to the mixing of large quantities of uncontaminated air this is called “dilution ventilation” and the dilution air must be in such quantities that the concentration of contaminants in the workplace is reduced to acceptable levels. In some very specialised cases, general ventilation can be applied in a way that creates an airflow through the contaminated space to displace contaminated air and replace it with uncontaminated air. This is known as “displacement ventilation”. Whilst there will always be a degree of mixing, this is particularly effective with sources of contaminant that move in a plume, such as high temperature emissions from furnaces.
- Local Exhaust Systems – Are used to capture a contaminant at or near its source thus ensuring that levels of contaminants do not reach unacceptable levels in the workplace. The common terminology for such systems is Local Exhaust Ventilation or LEV.

Other ventilation systems do exist (Table 6.1), however their application to the control of hazardous substances tends to be specific for certain types of process.

**Table 6.1 – Ventilation System Types**

System	Function
General Extraction	To remove and replace contaminated air (also known as dilution ventilation)
Local Exhaust	To remove contaminants at their source
Heating, Ventilation and Air-Conditioning (HVAC)	To mechanically provide fresh air for thermal comfort and health (known as general ventilation in some countries)
Natural	To dilute or displace contaminants in the air by using wind or temperature differences to induce airflow
Supply	To replace air removed from a ventilation system

## 6.3 BASIC PRINCIPLES OF VENTILATION

### 6.3.1 Definitions

When considering ventilation systems there are a number of basic definitions. These include:

#### a) Air Density

The density ( $\rho$ ) of air is defined as its mass per unit volume and at standard temperature and pressure (in ventilation this is normally 20°C and 10<sup>5</sup> Pa) is normally taken as 1.2 kg m<sup>-3</sup>. If non standard conditions exist, the density of the air can be calculated from the formula:

$$\rho_o = 1.2 \times \frac{b_o}{b_s} \times \frac{T_s}{T_o}$$

Where  $\rho_o$  = Air density at non standard conditions (kg m<sup>-3</sup>)

$b_o$  = Barometric pressure at non standard conditions (Pa)

$b_s$  = Barometric pressure at standard conditions (10<sup>5</sup> Pa (760 mm Hg))

$T_o$  = Absolute temperature at non standard conditions (°K)

$T_s$  = Absolute temperature at standard conditions (293°K)

#### b) Pressure

For air to flow there must be a pressure difference and air will flow from the higher pressure to the lower pressure.

Pressure is considered to have two forms; these being static pressure ( $P_s$ ) and velocity pressure ( $P_v$ ); with the sum of these being total pressure ( $P_t$ ). Thus:

$$P_t = P_s + P_v$$

Static pressure is defined as the pressure exerted in all directions by a fluid that is stationary. If the fluid is in motion (as is the case in a ventilation system), static pressure is measured at  $90^\circ$  to the direction of the flow so as to eliminate the influence of movement (ie: velocity). Static pressure can be both positive and negative depending if it is measured on the discharge or suction side of a fan.

Velocity pressure is defined as that pressure required to accelerate air from zero velocity to some velocity and is proportional to the kinetic energy of the air stream. In simple terms, velocity pressure is the kinetic energy generated in a ventilation system as a result of air movement. This can be expressed as:

$$P_v = \rho \frac{v^2}{2}$$

Where  $\rho$  = Density of air ( $\text{kg m}^{-3}$ )  
 $v$  = Air velocity ( $\text{ms}^{-1}$ )  
 $P_v$  = Velocity pressure (Pa ie  $\text{Nm}^{-2}$ )

If standard temperature and pressure conditions are in existence, ie:

$$\rho = 1.2 \text{ kg m}^{-3}$$

$$\text{Then } P_v = 0.6 v^2$$

The relationship between  $P_v$ ,  $P_s$  and  $P_t$  can be shown schematically as per Figure 6.1.

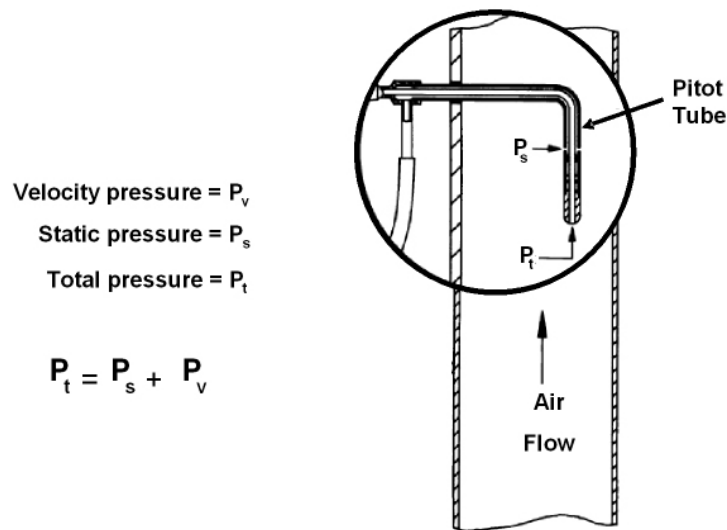

(Source: J Dobbie – reproduced with permission)

**Figure 6.1 – Relationships Between Velocity, Static and Total Pressure**

**c) Volume and Mass**

When a quantity of air is moving within a ventilation system the volumetric flowrate is a product of the velocity of the air and the cross-sectional area of the system through which it is flowing.

Thus  $Q = vA$

Where  $v =$  Average air velocity over the cross-section of the system ( $\text{ms}^{-1}$ )

$A =$  Cross-sectional area of the system where the velocity measurement was made ( $\text{m}^2$ )

$Q =$  Volume flow rate ( $\text{m}^3 \text{s}^{-1}$ )

**d) Capture, Face and Transport Velocity**

- Capture Velocity – is the air velocity required at the source of emission so as to cause the contaminant to move towards the capture device and thus be removed. Typical published capture velocities are provided in Table 6.2. However this often does not fully reflect the energy or location of the source (section 4) and should be used only as illustrative.

**Table 6.2 – Typical Capture Velocities**

Conditions of Dispersion of Contaminant	Examples	Capture Velocity (ms <sup>-1</sup> )
Released into still air with no velocity	Evaporation of solvents from degreasing tanks, paint dipping/drying, etc	0.3 – 0.5
Released at low velocity into moderately still air	Welding Soldering Liquid transfer	0.5 to 1.0
Released at moderate velocity into moving air	Crushing Spraying	1.0 to 2.5
Released at high velocity into very turbulent airstream	Cutting Abrasive blasting Grinding	2.5 to 10

(Source: HSE – reproduced with permission)

- Face Velocity – is the air velocity at the opening of an enclosure or hood. Similarly, the slot velocity is the air velocity at the opening of the slot.
- Transport Velocity – is the minimum air velocity required at any point in the ventilation system to ensure that collected particles remain airborne and are thus not deposited within any part of the system except the collector. In simple terms, the lower the density and size of the particles the lower the transport velocity. Recommended transport velocities are provided in Table 6.3.

**Table 6.3 – Recommended Transport Velocities**

Type of Contaminant	Transport Velocity (ms <sup>-1</sup> )
Gases (non-condensing)	No minimum limit
Vapours, smoke and fumes	10
Light, medium density dusts and powders (eg: sawdust, plastic dusts)	15
Average industrial dusts (eg: grinding dust, silica, wood shavings)	20



Type of Contaminant	Transport Velocity (ms <sup>-1</sup> )
Heavy dusts (eg: lead, metal turnings, dusts which are damp or tend to agglomerate)	25

(Source: HSE – reproduced with permission)

### 6.3.2 System Components

The basic components of a ventilation system depend on what type of system is being employed. For a local extraction system this will include a range of components described below, whereas general ventilation may be as simple as a series of openings in a building to allow air movement by thermal convection. A local exhaust system will include a hood to contain or capture the contaminant, a device to move the air – a fan or impellor, a system of ducting or trucking to transport the collected air to a point where it can be exhausted to the atmosphere and a means of discharging the air – a vent stack, or chimney. For hazardous contaminants some form of cleaning of the air will generally be necessary prior to the fan and before discharge. Irrespective of whether or not extracted air has been cleaned, it must be discharged to atmosphere in such a way that it does not re-enter the building (or any adjacent buildings) until the contaminant concentrations have been diluted to acceptable levels to meet environmental standards and to prevent contaminated air being drawn back into workplaces. The best methods of air discharge via stacks involve releasing the air to the atmosphere as high as is possible and at a high velocity.

The basic components of an LEV system are shown in Figure 6.2.

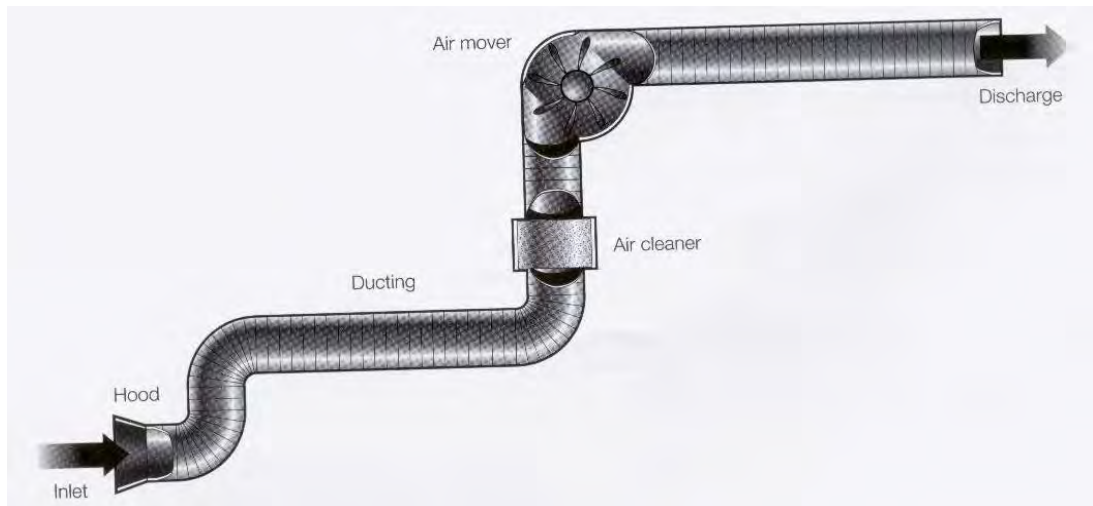

(Source: HSE – reproduced with permission)

**Figure 6.2 – Basic Components of an LEV System**

## 6.4 LOCAL EXHAUST VENTILATION SYSTEMS

### 6.4.1 Introduction

Local exhaust ventilation is the name given to a system designed for the purpose of removing an airborne hazardous substance near its source or point of origin. The basic LEV system consists of one or more hoods (the inlet into the system), ducting, air cleaner, fan (air mover) and a discharge point. A schematic diagram of a typical system is provided in Figure 6.3.

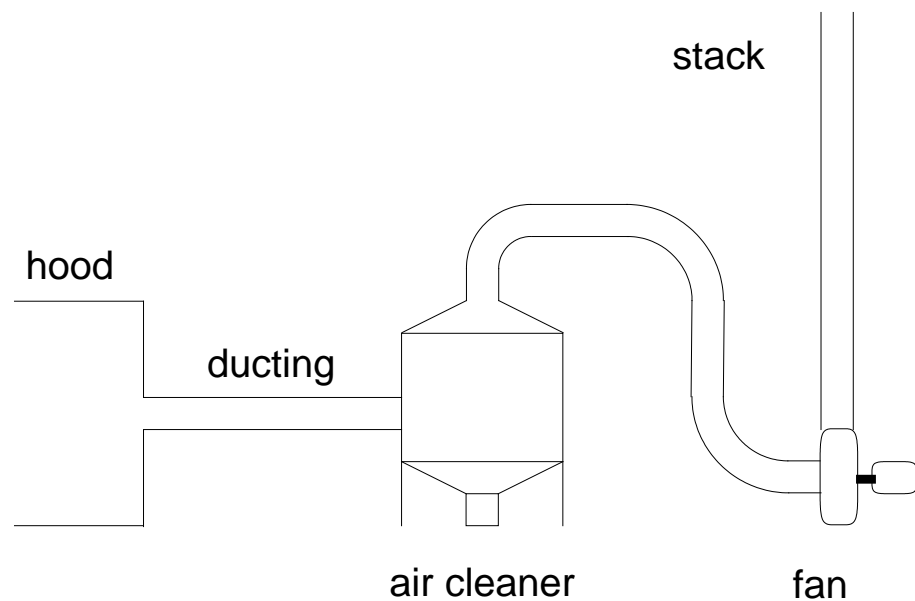

(Source: Diamond Environmental Ltd – reproduced with permission)

**Figure 6.3 – Typical LEV System**

LEV is often chosen as the method of controlling airborne hazardous substances due to the fact that the contaminant can be removed from the atmosphere prior to workers being exposed. While this may be the case, in theory, it is unfortunately rare to see a good LEV design in workplaces, as sufficient attention isn't paid to the requirements for efficient capture of the contaminant. A publication from the UK HSE titled "Controlling Airborne Contaminants at Work – A guide to local exhaust ventilation" (HSE 2008) has recognised this failure and provides excellent guidance.

#### **6.4.2 Hood Design**

One of the most important components in any LEV system is the hood and the effectiveness of the system can be defined in terms of how the contaminant cloud is contained, received or captured by the hood. Before designing an LEV system it is important to have a good understanding of the potential of exposure and the consequences of exposure so that the required degree of protection can be estimated. Only once the risks and the sources of emission of contaminant are fully understood, can a LEV system be designed to capture or receive the contaminant. Once the level of protection is determined and the capture or containment system is designed, it is possible to select from a number of component combinations to achieve this goal.

As air enters an extraction hood the airflow streamlines have to bunch together. This continues for a distance once the air is inside the hood leading to the formation of the "vena contracta" where the airflow is "bunched" towards the centre. The air at the edges of the hood in this region is not moving with the air entering - flow separation occurs. This flow separation leads to the formation of eddies, which can result in contaminated air escaping from inside the hood at the edges.

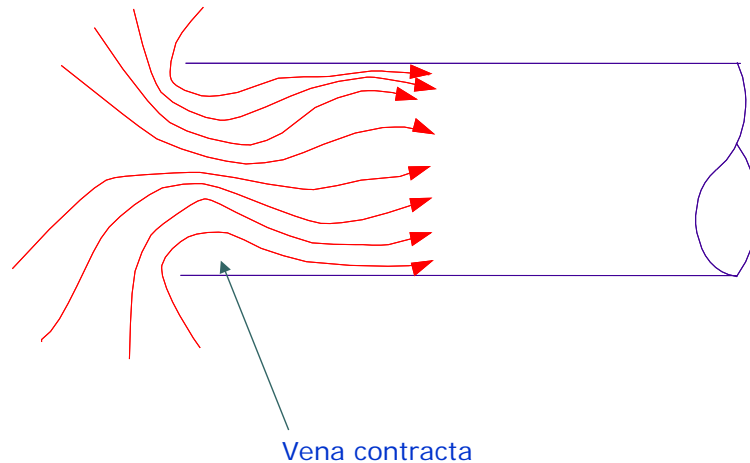

(Source: Diamond Environmental Ltd – reproduced with permission)

**Figure 6.4 – Airflow Pattern into an Exhaust Hood**

Other factors which can interfere with the air flow into the hood, leading to contaminant escaping include the presence of the operator, or other obstructions, in front of the hood and draughts blowing across the face of the hood.

To ensure effective control of contaminants, there are a number of basic rules which should be followed when designing a hood for a local extraction system:

- Enclose the source of the contaminants as far as possible. They are then contained and prevented from dispersing and the amount of air (and, therefore, energy) required to pull them into the system is minimised
- Utilise the momentum of the contaminants. Locate the hood so that they are already moving into it
- Capture as close as possible to the source of the contaminants so that they are captured before they disperse
- Pull the contaminants away from the workers
- Ensure that an adequate air velocity is achieved to pull the contaminants into the hood. The velocity required will depend upon both the nature of the contaminant and the process

- Minimise turbulence and eddies
- Apply ergonomic principles to ensure the system is easy to use and that the risk of musculoskeletal injury is minimised

Hoods can have many shapes and sizes, however they can be grouped under three basic categories. These are:

- Enclosing hoods
- Capturing hoods
- Receiving hoods

These types are illustrated by the HSE (2008) and reproduced in Figure 6.5. It should be noted that the orientation of the worker in these diagrams would generate significant turbulence. The correct orientation is shown in Figure 6.7.

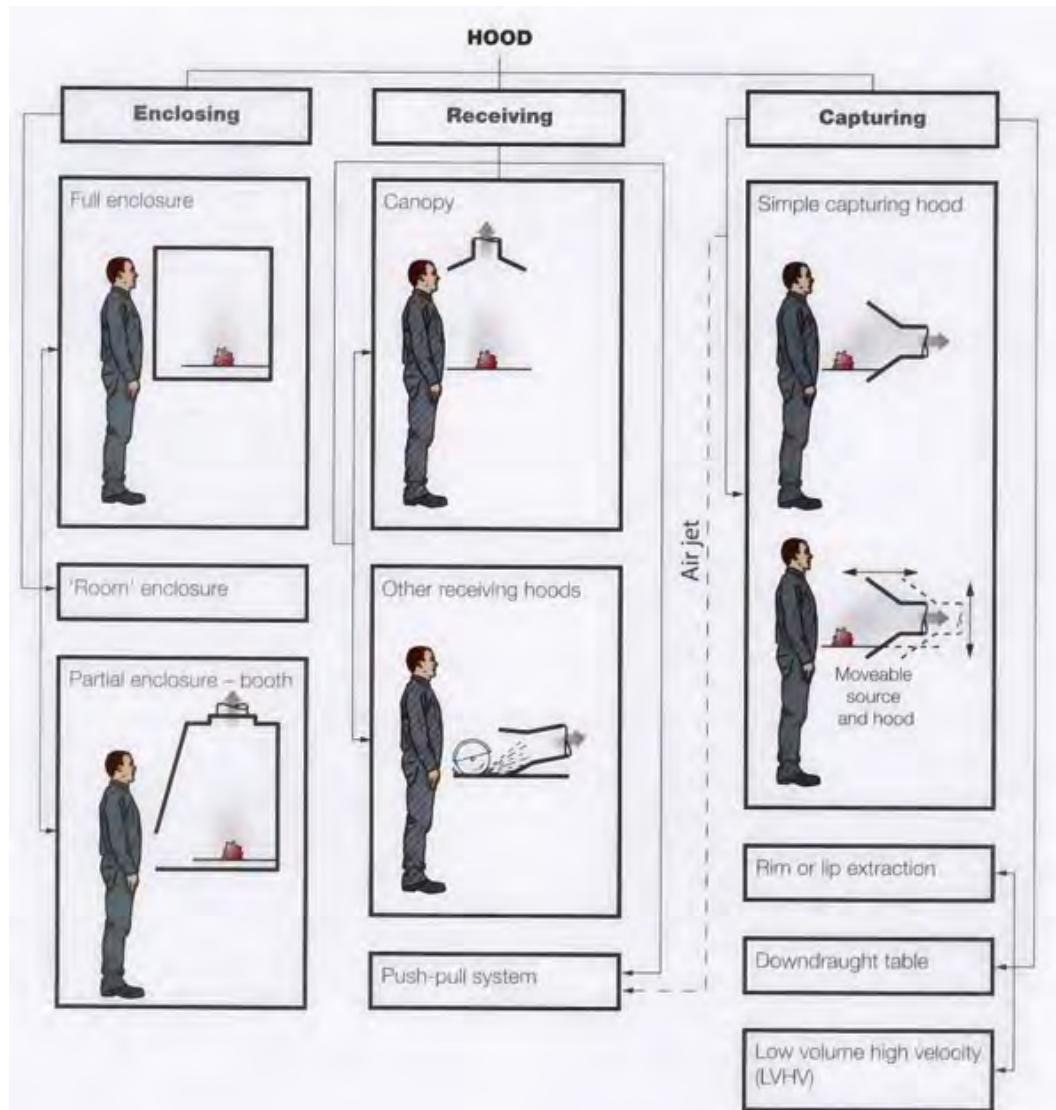

(Source: HSE – reproduced with permission)

**Figure 6.5 – Categories of Hood Designs**

**a) Enclosing Hoods**

Enclosures are designed to surround, to a large extent, the process or task requiring ventilation, with the common forms of these devices being booths and fume cupboards. The aim of an enclosure is to maintain a negative pressure within the enclosure so that any sudden release of contaminant does not escape to the surrounding environment.

The HSE (2008) provide an excellent discussion on the design principles for enclosures and this or similar literature should be consulted prior to selecting an enclosure for a specific task.

**Total enclosures** provide the greatest degree of worker protection as they are outside the enclosure where the contaminants are generated and contained. These hoods also minimise the amount of air which needs to be extracted, thereby conserving energy. Examples of total enclosures include:

- glove boxes
- enclosed chemical production plant



(Source: Diamond Environmental Ltd – reproduced with permission)

**Figure 6.6 –A Total Enclosure of an Abrasive Cleaning Process**

An extension of enclosures is the **room enclosure**, more typically known as booths (abrasive-blasting, spray painting) or in some countries rooms or cabins. In these devices the operator and process are totally enclosed with the operator in the majority of cases wearing respiratory protective equipment such as an air-supplied respirator.

**Partial enclosures** are a means of providing accessibility with a reasonable level of containment. The hood should be designed so that the contaminant is generated within it, so that the source is enclosed as much as possible. The hood opening(s) should be made as small as possible to minimise the amount of air extracted and maintain a high enough face velocity to make sure the contaminant cannot escape.

With larger booths the operator may stand inside the hood. Care has to be taken to prevent exposure to contaminants in such cases. If the worker stands facing the extraction with his back to the airflow into the booth, the airflow is obstructed leading to the formation of eddies. The worst case is where he stands facing the entry which can lead to high exposure to the contaminant which will be drawn towards his breathing zone. The best position to adopt with these large "walk-in" booths is right angles to the airflow, although some contaminant may still be drawn across his breathing zone if there is significant turbulence.

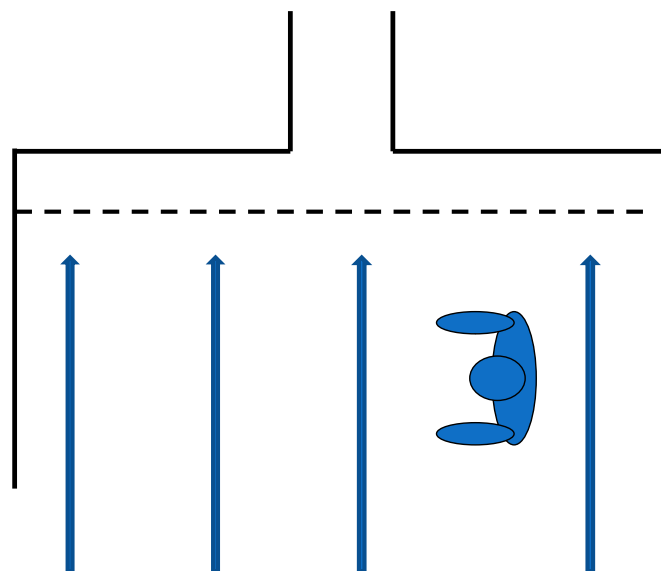

(Source: Diamond Environmental Ltd – reproduced with permission)

**Figure 6.7 –Personnel working inside a Partial Enclosure should stand at Right Angles to the Airflow**

In some industries, such as pharmaceutical manufacturing, specially designed laminar flow booths are used for tasks such as weighing out powders. Again the worker is inside the booth with the process, but these booths are specially designed to give laminar flow, where the air moves in predictable streamlines. The worker stands at right angles to the flow so that the contaminants are entrained by the airstream and removed without passing through the breathing zone. There are two main types of design - horizontal flow and down flow.



Good design of such booths is required to ensure that good laminar flow is achieved and that contaminants are not moved through the breathing zone. Correct operating procedures must be followed so that the worker stands in the correct position - i.e. side on to the air flow.

Smaller partial enclosures are designed such that the operator is outside the enclosure and removed to some degree from the contaminant source. Transparent barriers (screens) may be placed between the operator and the contaminant as is usually the case with fume cupboards.

The main technical limitation of partial enclosures is that contaminated air can escape from the booth. This can occur for a number of reasons. As the air enters the hood eddies are created which can lead to contaminated air spilling out.

Good design of the entry to minimise eddies and turbulence and thus even air flow across the face of the booth can minimise leakage. Key design considerations are:

- Can a side flow or down draught booth be used instead of the traditional backdraught type?
- Use baffles or filters to create a plenum to even out the flow inside the booth
- Design the booth entry so that it guides the air into the hood gently
- Ensure the booth is deep enough to allow the contaminant source to be located far enough from the worker's breathing zone (the depth should be at least 75% of the largest face dimension)
- Minimise the size of the face opening – use transparent panels in front of the worker's face and breathing zone (Figure 6.8)

As a general rule, face velocities should never be below  $0.5 \text{ ms}^{-1}$  and levels of  $>1 \text{ ms}^{-1}$  should be maintained for more toxic contaminants or particles generated with high momentum in the process. These are generalisations and each contaminant must be assessed on its relative merits.

**Table 6.4 – Suggested Face Velocities for Partial Enclosures**

Source Conditions	Face Velocity (m/s)
Gases and vapours	0.5 to 1.0
Dusts	1.0 to 2.5



(Source: Diamond Environmental Ltd – reproduced with permission)

**Figure 6.8 – A Small Booth fitted with a Glass Panel**

#### **b) Capturing Hoods**

In this case the contaminant is generated outside the hood. Sufficient velocity has to be generated to capture the contaminant, overcome extraneous air movement and pull it into the hood.

The velocity required to achieve this is commonly referred to as the capture velocity. The required capture velocity in a particular situation will depend upon how the contaminant is generated - whether it has a high or low velocity - and its density.

Capturing hoods are widely used because they are relatively easy to retrofit, do not interfere with the process as much as other systems and are commercially available as “off-the-shelf” items.



(Source: Diamond Environmental Ltd – reproduced with permission)

**Figure 6.9– A Typical Capture Hood**

As the air is not pulled solely from a single direction, the air velocity rapidly decreases with distance from the face of the hood. In fact with a simple round captor hood, the velocity one duct diameter in front of the hood will be less than 10% of that achieved at the face (ie: the point of entry into the hood). Consequently, they have a limited zone of influence (“capture zone”) where effective capture of contaminants can be achieved.

The extent of this zone needs to be properly established to ensure that the hood is positioned correctly in relation to the source of contamination.

The relationship between the capture zone of the hood, the working zone and the operator's breathing zone are critical in ensuring employee exposures are controlled. This is demonstrated very effectively in Figure 6.10.

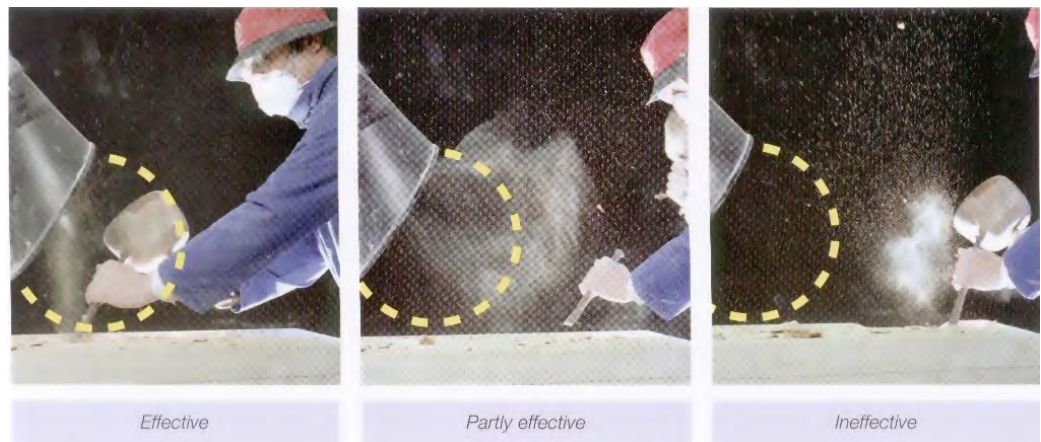

(Source: HSE – reproduced with permission)

**Figure 6.10 –Capture, Working and Breathing Zones**

Unfortunately, capturing hoods are often much less effective than intended due to the following issues:

- Poor understanding of the source or motion of contaminant
- Capture zone too small
- Capture zone disrupted by cross drafts
- Capture zone does not include the working zone
- Process requirements moves the working zone outside the capture zone
- Incorrect calculation of capture zone
- Movement of the source

- The capture zone can shrink and expand depending on conditions such as cross drafts. It is almost always smaller than the user expects

While these issues can often be resolved, in many cases it is much simpler to choose an alternate design option, eg: a partial enclosure.

The effectiveness of an exterior hood can be improved, albeit by a small factor, by flanging and by increasing the degree of enclosure of the contaminant source. This minimises the amount of "clean" air pulled into the system, thereby reducing the volume flow required to achieve control over the contaminant. Figure 6.11 demonstrates how a flange can reduce the amount of air from behind the hood entering the system and thus extending the range of the hood to capture contaminated air, albeit to a limited extent.

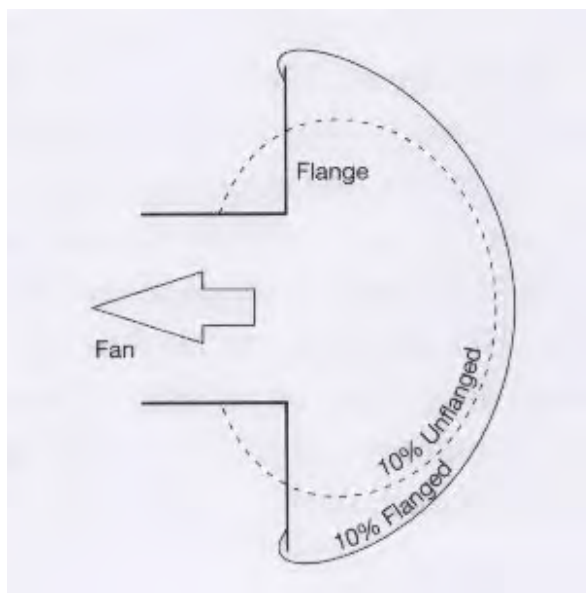

(Source: AIOH 2007 – reproduced with permission)

**Figure 6.11 – Effectiveness of a Flanged Hood**

Flanges also smooth airflow and reduce the degree of flow separation, which in turn minimises the degree of turbulence and maximises the hood efficiency.

**Slots** are hoods where the width-length aspect ratio is less than 0.2. Slots are often used where accessibility is constantly required or where process materials are required to constantly enter the system. They are commonly used on degreasing tanks, cleaning baths and electroplating tanks so as to remove any contaminant vapours released in the tanks or bath from the parent solution. On smaller tanks, one slot is usually sufficient, positioned along the longer edge of the tank. With larger tanks, two slots, on opposing sides, are required. However as they work against each other, there will be a “dead” zone in the centre of the tank.

Gardiner & Harrington (2005) indicate that it is difficult to pull air into a slot from a distance of greater than 0.75 m and the distribution of air movement along the slot length needs to be managed. For example if the duct connection to the slot is placed at one end, very little air will be drawn into the slot at the opposite end, thus creating an imbalance. This can be overcome to some degree by the insertion of air splitters, however more careful location of the duct at the design stage will minimise this problem.



(Source: Diamond Environmental Ltd – reproduced with permission)

**Figure 6.12 – A Plating Tank with Slot Extraction Along One Edge**

In some situations it may be necessary to improve the capture efficiency of the system and this can be achieved by the inclusion of a supply slot on the opposite side of the tank, etc. This is commonly known as a “push-pull” system.

There are a number of issues with **push-pull ventilation systems**. These include:

- High air velocities over the surface of a liquid in a tank will result in increased evaporation
- Any interruption of the air jet (push side of the system) will result in contaminant-laden air being deflected and potentially increasing the exposure of workers

**Low Volume High Velocity (LVHV)** systems are a special type of capture hood sometimes used on hand tools where the more common types of extract hood are impracticable. The contaminant is captured close to its source utilising a high velocity (50 to 100 ms<sup>-1</sup>) through a small opening. The small hood area means that very low volumes of air can be used to attain effective control. LVHV systems have also been successfully used on soldering irons, lathes and belt sanders. Although these systems have a low volume flow, commonly less than 10% of "conventional" systems, the small diameter hoods and ducting (often flexible pipework) utilised, results in very high pressure losses.



(Source: Diamond Environmental Ltd – reproduced with permission)

**Figure 6.13 – An LVHV System used on a Soldering Iron**

Whatever type of capture hood design is used, to ensure effective control:

- The source of contamination must be completely located inside the hood capture zone
- There must be sufficient velocity to draw the contaminant into the hood (“capture velocity”).

The AIOH (2007) suggest the following simple principles to make capture hoods more effective. These include:

- Placing the hood as close as possible to the source, preferably enclosing it
- If the source includes fast-moving particles, positioning the hood to receive those particles
- Specifying a ‘capture velocity’ at a point greater than the particle velocity

### **c) Receiving Hoods**

In receiving hoods the process is located outside the hood and the contaminants make their own way into the hood due to their momentum. They include canopy hoods located over hot processes where the contaminants rise due to thermal uplift, and hoods used on grinding processes where a large proportion of the contaminants generated are directional.



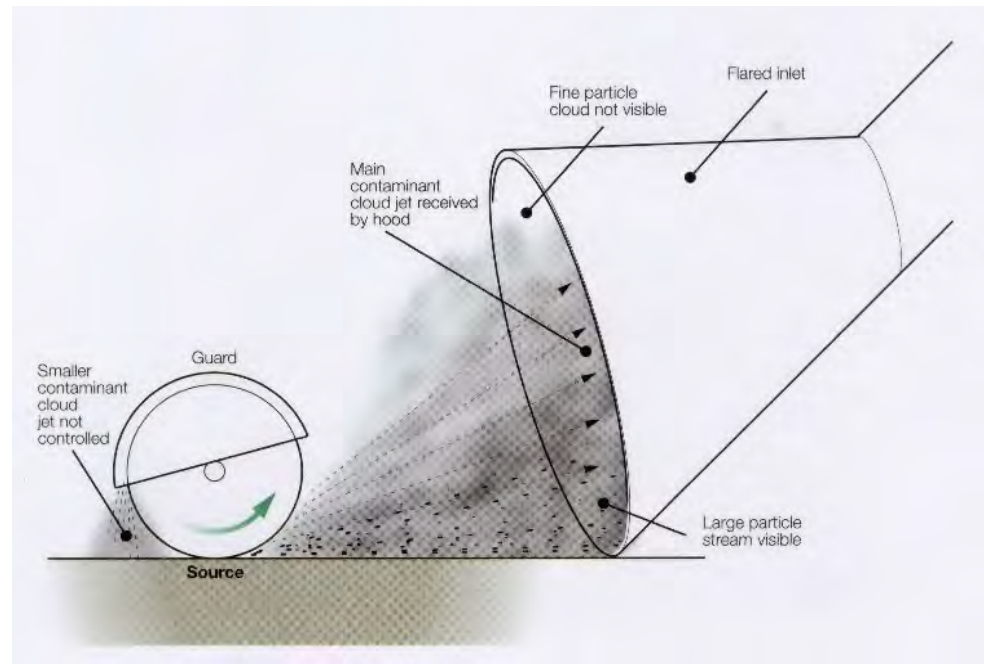

(Source: HSE – reproduced with permission)

**Figure 6.14 – Receiving Hood**

Receiving hoods can be applied in situations where a process produces a contaminant cloud that has a predictable strength and direction (Figure 6.14 illustrates these principles). It is important to note that the receiving hood must be large enough and close enough to effectively collect the contaminant cloud and other high velocity materials generated from the source. They are only applicable to situations where workers do not have to position themselves between the source of contamination and the hood entry.

With a canopy hood over a hot process, contaminants are transported into the hood in the rising airstream. Hence it is important to ensure that all the contaminated air enters the hood. To achieve this, the hood should be positioned as close as possible to the source. Also, as the plume of hot contaminant rises it begins to spread, so the hood should be wider than the source so that contaminant does not drift around the sides of the canopy. Installing curtains made of a suitable material, suspended from the side of the canopy can improve their performance – effectively turning them into a partial enclosure (see Figure 6.15).



(Source: Diamond Environmental Ltd – reproduced with permission)

**Figure 6.15 – Canopy Hoods used to Control Hot Oil Mist and Fume**

As receiving hoods do not actively capture the contaminant, the recommended values of capture velocities given above are not applicable. However, the airflow needs to be sufficient to remove all the contaminated air entering the hood. If it is not, then contaminants will “spill out” and re-enter the workplace. It is also essential that workers are not placed between the source and the hood as they will otherwise be in the stream of contaminated air.

### **6.4.3 Ductwork**

The supply of air via a ventilation system is dependent on the transfer of air from one point to another via ductwork. The key design requirements are that the ductwork contains the contaminated air, resists abrasion and chemical attack, so that leaks do not develop, and that there is sufficient air velocity to keep any contaminants suspended, so they do not settle out and cause a blockage.

Ducting is usually made from galvanised steel however other materials such as stainless steel, PVC, aluminium, fibreglass, brick or concrete can be used.

It is usually formed into circular or rectangular sections and the shape and size of ducts are designed to fit the needs of the ventilation system, building and associated plant.

When selecting the size of ducting for a particular application a number of factors need to be considered. For example, for a given volume flowrate the larger the duct size the lower the air velocity and absorbed energy (friction) but the bigger the capital cost. Circular cross section ducting is more economical in terms of aerodynamic efficiency and construction materials but space requirements may dictate the use of rectangular cross section ducting.

When designing any duct system some points need to be remembered to keep the air flowing as smoothly and efficiently as possible. These include:

- Keep the design as simple as possible
- Keep the number of bends and junctions to a minimum so as to reduce flow resistance
- When changes in direction are necessary they should be made smoothly. The centreline radius should ideally be 2.5 times the duct diameter
- 'T' junctions should never be used. Ideally branches should join the main duct at an angle of 30 to 45 degrees
- Duct diameters should be increased after intersections to compensate for the increased volume flow (total ducting area should be kept constant to maintain constant velocity). Tapered sections should be used when the duct cross section needs to change
- Avoid long lengths of flexible ducting, especially where high flow resistance is present
- Avoid 'U' bends as they act as traps for particles and can eventually block the duct
  - Where possible design the system to minimise or eliminate the need for flow balancing dampers

If there is a need to maintain a particular transport velocity and thus a required volume flowrate is established, the duct cross section can be calculated from the base formula:

$$Q = vA \quad (\text{see Section 6.3.1})$$

In terms of an overall duct system it is inevitable that there will be losses, mainly due to friction, and these are expressed in terms of pressure loss. There is a need to calculate all these pressure losses over the length of the system and the sum of these represents the total pressure loss of the system. From this the duty of the fan can be established, being the calculated volume flowrate at the total pressure loss. To ensure that an appropriate fan is selected the velocity pressure at a set discharge velocity (irrespective of what the set value is) must be added to the total pressure loss as this represents the overall energy that the fan must provide. Failure to make this adjustment will result in the fan being undersized for the duty for which it is required.

Once the decision has been made to install ductwork there are a number of factors which need to be considered as these will affect the final design. These are:

- *What construction materials should be used?*  
In most cases galvanised steel is normally used, however if corrosive gases or vapours are present, materials such as stainless steel or plastic would be used.
- *What velocity should be maintained in the duct?*  
This is dependent on the type of contaminant to be carried. For particles such as fumes, zinc and aluminium, velocities of 7-10 ms<sup>-1</sup> would be adequate. For heavy moist dusts velocities of greater than 22.5 ms<sup>-1</sup> would be required, which can result in high noise levels.
- *What cross section shape should be used?*  
Circular cross section is preferred, however, in some cases due to space constraints, rectangular cross sections may be necessary.

Once a system has been installed it will require balancing to ensure that each branch of the system is operating at its maximum performance. The process of balancing a system needs to be undertaken systematically as the restriction of airflow in one branch will alter the airflow rate to all other branches of the system. With good design the need for balancing can be minimised. Where balance through design is not possible, flow balancing dampers may be necessary.

Balancing requires starting at each hood or branch and making adjustments while working towards the fan. Serious problems can arise if major imbalances in a system are corrected by just using dampers.

The correct balancing or rebalancing of a system is a highly skilled activity and should only be conducted by experienced persons.

In any duct system it is important to provide leak-proof inspection openings to allow for the inspection and cleaning of ducts. It is also important to provide test points where at a minimum the static pressure can be measured.

These should be located after each hood or enclosure, at key points in the duct system and at certain components to measure pressure drops (ie: fans and filter).

#### **6.4.4 Fans**

A fan consists of a series of blades (impeller) mounted on a central axis (shaft) which is connected to an energy source (fan motor). These components are then enclosed within a casing or housing which creates a pressure difference (and hence airflow) between the inlet and outlet by the rotation of the impeller.

There are five common types of fans, these being:

- Propeller Fans – consist of fan blades (metal or plastic) connected to a hub which is attached directly to an energy source (electric motor) or via a belt system. Propeller fans are generally low in efficiency and are not suitable for ducted or air filtration systems. Propeller fans are most often used for general or dilution ventilation.

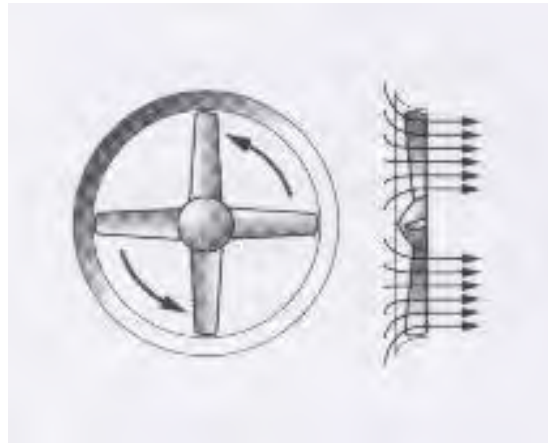

(Source: HSE – reproduced with permission)

**Figure 6.16 – Propeller Fan**

- Axial Fans – consist of a cylindrical casing with the shaft of the impeller being at the centre of the casing. The impeller blades usually have an aerofoil shape and rotate within the casing with their tips very close to the casing. While axial fans are similar in principle to propeller fans they produce slightly higher pressures. Axial fans are not normally mounted within ventilation system ductwork. Where they are they are only useful in systems with lower resistances, for example small systems moving gases or vapours with no air cleaning devices.

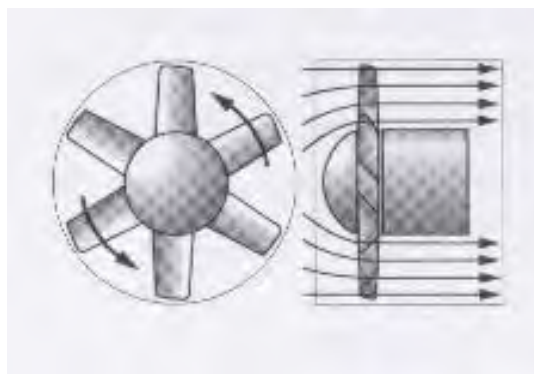

(Source: HSE – reproduced with permission)

**Figure 6.17 – Axial Fan**

- Centrifugal Fans – consist of a rotating impeller shaped like a paddle wheel which moves air drawn into the centre of the impeller towards its outer edge where it is collected in a specially designed casing, and ejected at a tangent to the impeller (Figure 6.18).

Because of their design, centrifugal fans generate large differences in pressure and thus higher airflows against the resistance of an LEV system. Blade shape changes the characteristics of the fan in the following ways:

- Radial blade (or paddle-bladed) centrifugal fans are robust, easy to repair, clean and maintain. They are used in applications where highly corrosive air or heavy dust loads are present
- Forward bladed fans have many small blades with their tips inclined towards the direction of rotation. This design gives rise to an overall compact fan where space is limited but is not suitable for dusty systems. They are good at moving large volumes of air against low resistances and so are mainly used in simple ventilation systems.
- Backward bladed fans have fewer, deeper blades than the forward bladed system and are less compact. They are the most common type of fan used for dust laden air and in large systems. They are good at moving moderate volumes of air against a high resistance

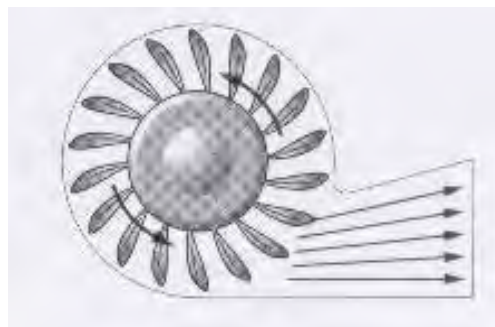

(Source: HSE – reproduced with permission)

**Figure 6.18 – Centrifugal Fan**

- Turbo Exhausters or Multistage Centrifugal Fans - can produce very high pressures to power low volume but high velocity systems. These are special fans that require protection of their precision blades from damage caused by dust, etc

- Compressed Air Driven Air Movers - are used where electrically powered fans are unsuitable – for example in atmospheres where fire or explosion may be a risk. The advantages are their relatively small size which makes them reasonably portable while their disadvantages are their high cost of operation and excessive noise

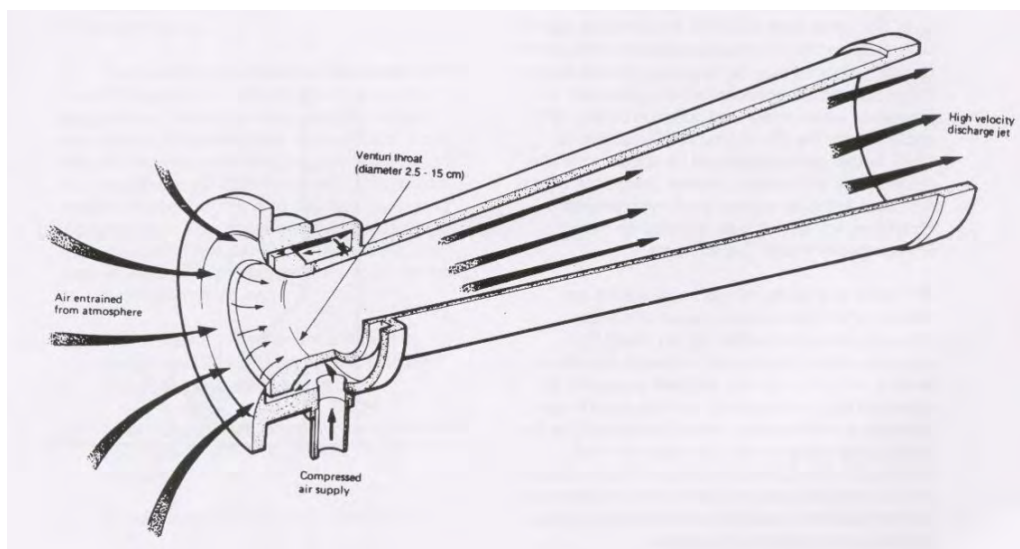

(Source: HSE – reproduced with permission)

**Figure 6.19 – Air Movers**

It is essential that an expert is consulted before a fan is selected as there are many factors to consider. The most important considerations, however, are what air flow is required and what resistance must be overcome.

The system resistance varies with the air flow (resistance being approximately proportional to the square of the air flow). A system curve can be produced which shows how the resistance (expressed as the static pressure) varies with air flow. The airflow generated by a given fan will depend on what resistance has to be overcome. The maximum airflow occurs where there is no resistance to overcome. On the other hand if the fan inlet is blocked off completely (resistance is at its maximum value) no airflow occurs. A fan curve can be produced showing the relationship between the air flow and fan static pressure. The exact shape of the fan curve depends on the fan type.



At high static pressures and low volume flows, fan curves have a characteristic stall region. Operation in this area is leads to erratic airflow that generates excessive noise and vibration, and should be avoided.

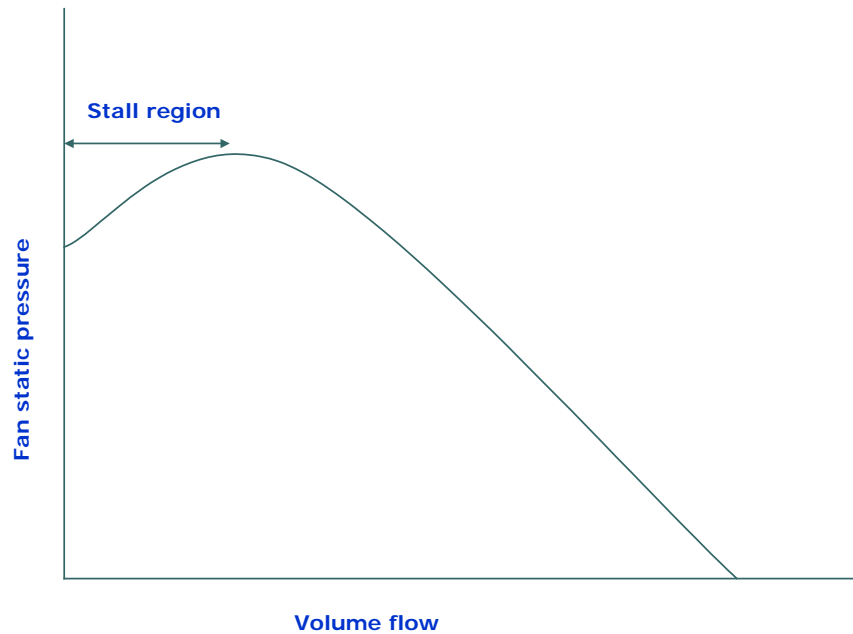

(Source: Diamond Environmental Ltd – reproduced with permission)

**Figure 6.20 – A Typical Fan Curve for a Backward Curved Blade Centrifugal Fan**

If the system and fan curves are plotted on the same chart, the point where they intersect gives the duty point which shows what airflow will be achieved when the fan is installed in the system.

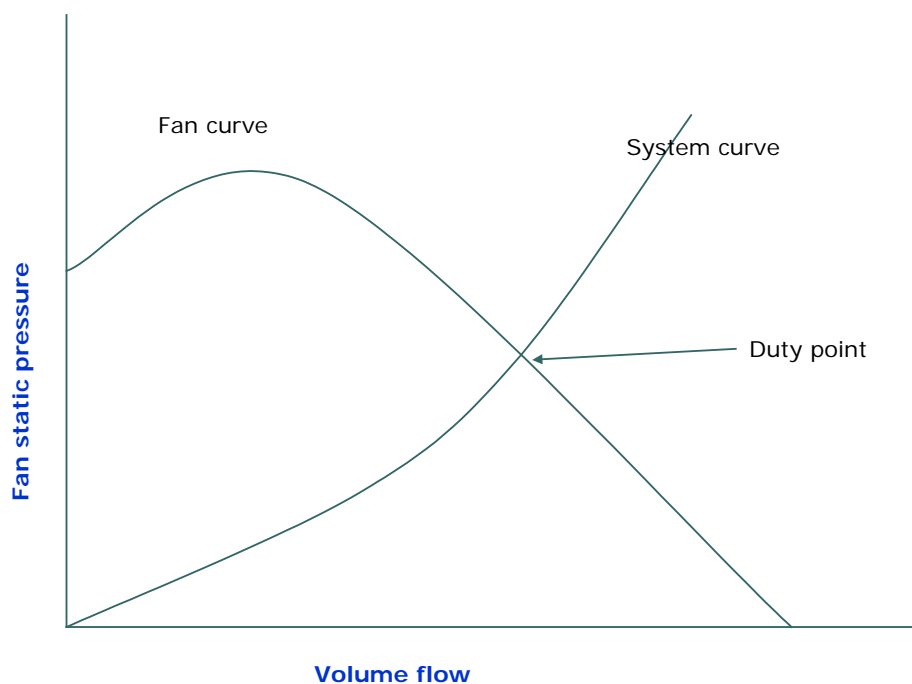

(Source: Diamond Environmental Ltd – reproduced with permission)

**Figure 6.21 – Fan and System Curve – used to select a suitable fan**

The duty point cannot be changed without altering the fan speed or making changes to the system which will change its system curve.

#### 6.4.5 Air Cleaners

With a properly integrated LEV system, careful thought needs to be given to the selection on an appropriate air cleaning device. The main reasons why this is required are:

- Compliance with environmental legislation
- Preventing contaminated air re-entering the workplace or other adjacent workshops
- Economic considerations such as the recovery of expensive materials

There are many different types of air cleaning devices on the market. These vary in effectiveness for different contaminants and in different situations. It is therefore important to ensure that the right equipment is selected for the particular situation encountered when designing a LEV system.

The common types of air cleaning methods are listed in Table 6.5.

**Table 6.5 – Types of Air Cleaners**

Contaminant	Type of Air Cleaner	Performance & Comments
Particulates	Cyclone	Poor at low particle sizes (2 $\mu\text{m}$ = 0%, 5 $\mu\text{m}$ = 50%) but good at larger sizes (8 $\mu\text{m}$ = 90%).
	Electrostatic Precipitator	<5 $\mu\text{m}$ 80 - 99% 5 - 10 $\mu\text{m}$ 99% Poor performance with particles that have a very low or high electrical conductivity.
	Fabric Filter	Very good for small particle sizes but flow resistance increases as dust builds up on filter.
	Wet Systems such as Venturi Scrubbers, Cyclones, etc	Lower performance (20 – 80%) with particles <5 $\mu\text{m}$ but >95% with particles >5 $\mu\text{m}$ . Produces a sludge which requires disposal.
Gases & Vapours	Adsorption	Most common are activated carbon filters, however the filter can fail suddenly when saturated.
	Chemical Scrubbing	Suitable for specific contaminants.
	Thermal Destruction	Combustion may produce unwanted by-products.

(Source: HSE – reproduced with permission)

Particulate collectors are the most common group of air cleaning devices normally associated with LEV systems. There various types including fabric filters (bag filters), cyclones, electrostatic precipitators and scrubbers.

Schematic diagrams of these systems are provided in Figures 6.22 - 6.26 and a simple explanation of their operation can be found in the HSE publication "Controlling Airborne Contaminants at Work" (HSE 2008).

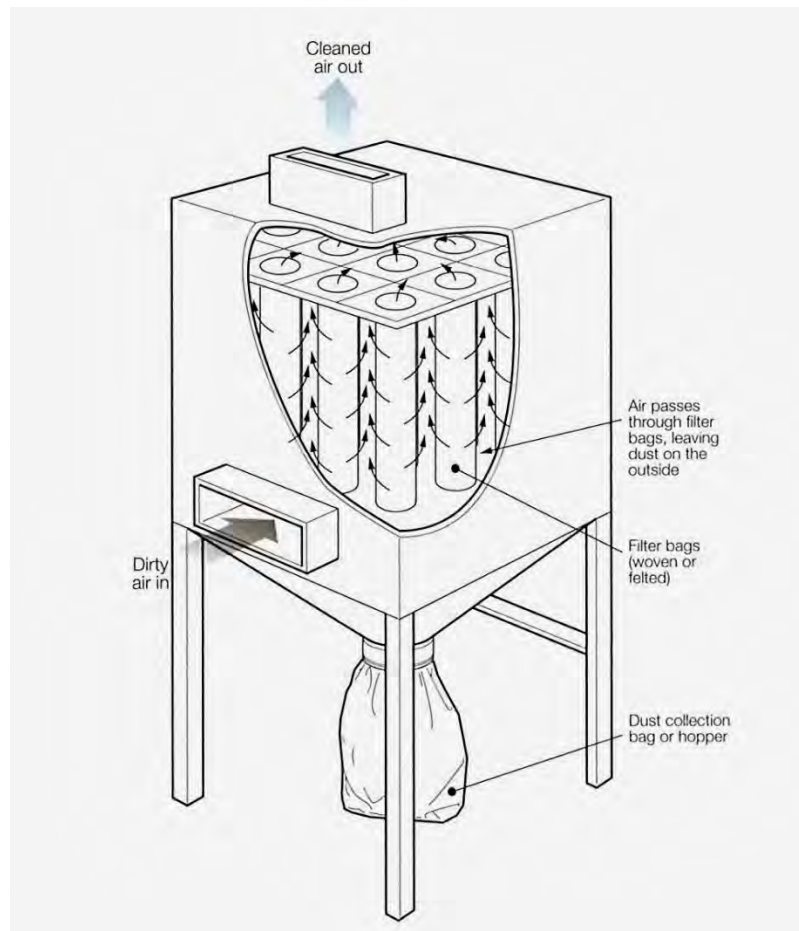

(Source: HSE - Reproduced with permission)

**Figure 6.22 - Schematic of a Fabric Filter**

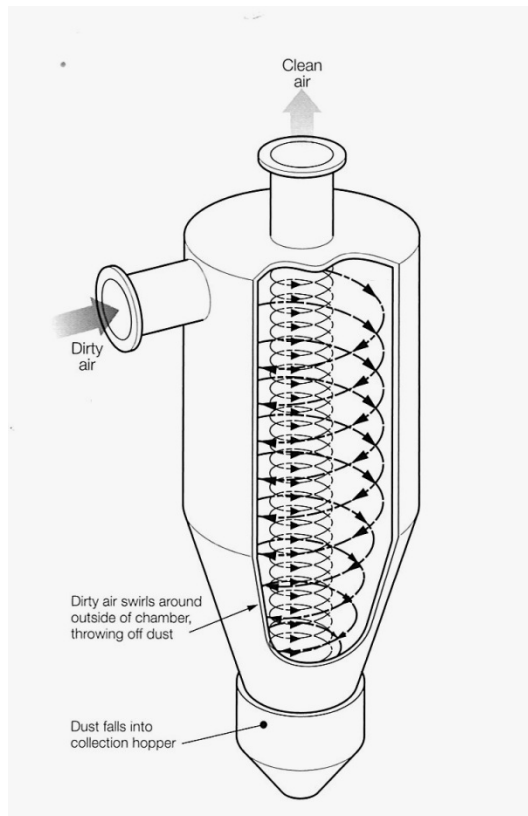

(Source: HSE - Reproduced with permission)

**Figure 6.23 - Schematic of a Cyclone**

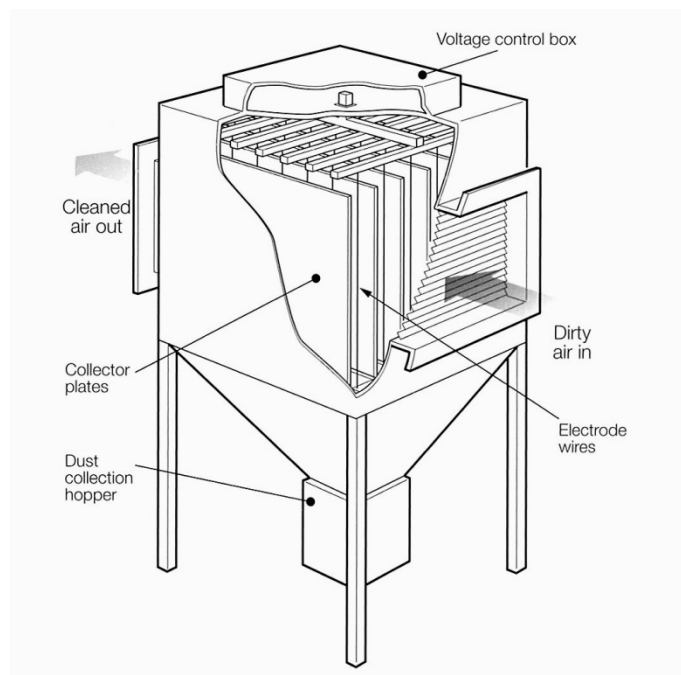

(Source: HSE - Reproduced with permission)

**Figure 6.24 - Schematic of an Electrostatic Precipitator**

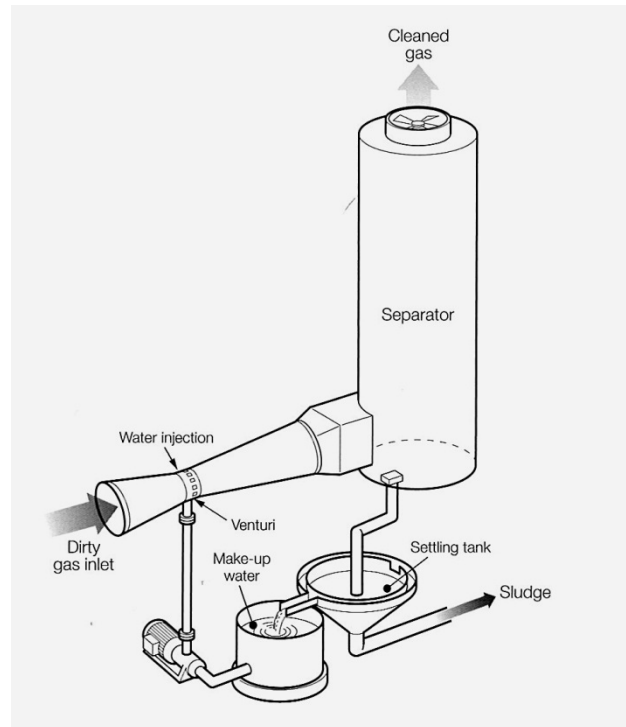

(Source: HSE - Reproduced with permission)

**Figure 6.25 - Schematic of a Venturi Scrubber**

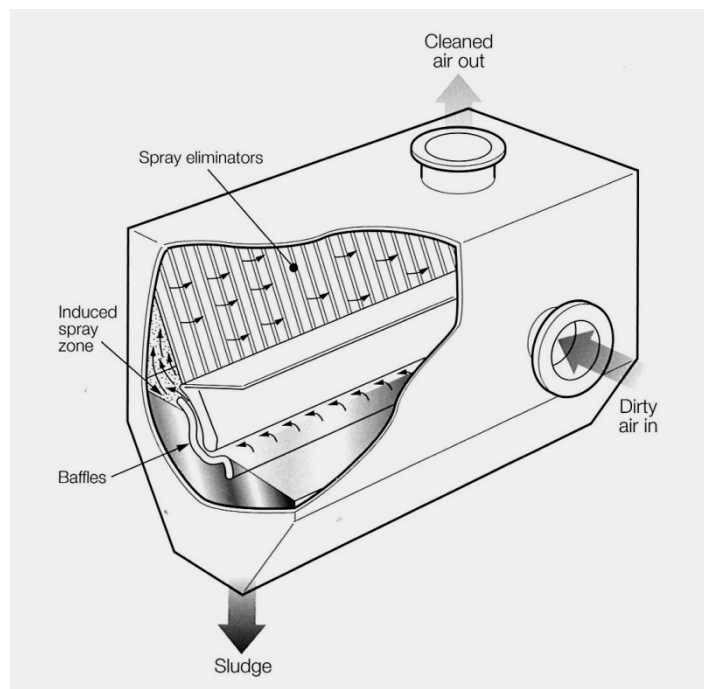

(Source: HSE - Reproduced with permission)

**Figure 6.26 - Schematic of a Self Induced Spray Collector**

#### **6.4.6 Discharge to the Atmosphere**

Irrespective whether or not extracted air has been cleaned, it must be discharged to atmosphere in such a way that it does not re-enter the building (or any adjacent buildings) until the contaminant concentrations have been diluted to acceptable levels to meet environmental standards and to prevent contaminated air being drawn back into workplaces. The best methods of air discharge via stacks involve releasing the air to the atmosphere as high as is possible and at a high velocity.

Devices such as cowls and weather caps which direct the discharged air downwards should be avoided. They create a large resistance to airflow, reducing the efficiency of the system, and prevent contaminants being dispersed.

When designing discharge systems there is a necessity to understand the airflow patterns around the location of the discharge so that the best possible location can be achieved.

With some contaminants it may be appropriate to incorporate an appropriate treatment system to reduce the level of contaminant to acceptable levels before discharge into the atmosphere. .

#### **6.4.7 Measurement and Testing of LEV Systems**

The performance of every ventilation system needs to be established and routinely monitored. Ideally, an initial appraisal should be undertaken during commissioning of a competently designed LEV system to check that it conforms to the design specification and is achieving adequate control of the contaminants in practice. The system supplier should be asked to provide this information as a condition of purchase.

Routine checks should be undertaken at appropriate intervals and thorough examinations and tests at least once a year and the results documented. The frequency of these tests should be determined based on factors such as system age and reliability and the consequences of failure. The critical success factor for any system is whether it effectively controls personal exposures. A reassessment of the risk post installation, including exposure monitoring, is advisable during the commissioning or routine testing of any control system, including ventilation.

The operating criteria which need to be defined will depend on the system design, but will typically include the following (as appropriate):

Hoods	<ul style="list-style-type: none"> <li>• Assessment of effectiveness at controlling contaminants</li> <li>• maximum of hoods to be in use at any one time</li> <li>• location and working position of each hood</li> <li>• static pressure behind each hood face velocity (for partial enclosures)</li> <li>• capture velocity at furthest source of contaminant generation from hood and face velocity (for captor hoods)</li> </ul>
Ducting	<ul style="list-style-type: none"> <li>• dimensions</li> <li>• transport velocity</li> <li>• volume flow</li> </ul>
Air cleaners	<ul style="list-style-type: none"> <li>• specification</li> <li>• volume flow</li> <li>• static pressures at inlet, outlet and across cleaner</li> </ul>
Fan (or other air mover)	<ul style="list-style-type: none"> <li>• specification</li> <li>• volume flow</li> <li>• static pressure at inlet</li> </ul>
Systems returning exhaust to the workplace	<ul style="list-style-type: none"> <li>• filter efficiency</li> <li>• concentration of contaminant in returned air</li> </ul>



**a) Air Velocity**

A number of instruments are available to measure air velocity, including vane anemometers, hotwire anemometers and pitot tubes.

The rotating vane anemometer consists of a number of blades that are configured to allow the air movement to rotate them in one direction. The number of rotations are then counted over a period of time (usually 1 minute) and converted to air velocity. These devices are not accurate at low air velocities, are not omni-directional and cannot be used where the direction of airflow is variable.



(Source: University of Wollongong)

**Figure 6.27 – Vane Anemometer**

The hot-wire anemometer works by an electrical current heating the sensor to a temperature above ambient and being cooled by air movement: the amount of cooling is dependent on the air velocity, the ambient air temperature and the characteristics of the heat element. These devices are directional and can be inaccurate in low air velocities due to natural convection of the hot wire. Caution also needs to be exercised when using these devices in the presence of flammable or explosive gases and vapours as most units are not intrinsically safe for use in such conditions.



(Source: University of Wollongong)

**Figure 6.28 – Hot-wire Anemometer**

Pitot tubes (or more correctly pitot-static tubes) are designed to measure the pressures inside a ventilation system. Depending on how the system is set up, it can be used to measure, static, velocity or total pressure. The measuring system consists of two concentric tubes with one facing directly into the airflow and the other (external tube) having a series of holes at 90° to the airflow. The two tubes are then connected to a manometer or pressure gauge and the velocity pressure recorded by the differential between total and static pressure. This process is demonstrated schematically in Figure 6.29. A modern instrument is shown in Figure 6.30.

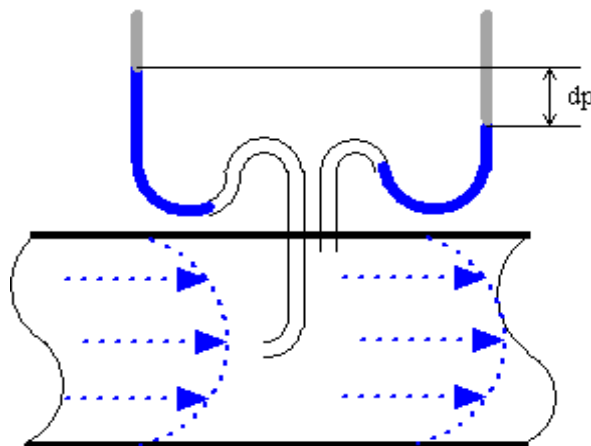

(Source: The Engineering Toolbox - reproduced under conditions of copyright)

**Figure 6.29 – Principle of the Pitot Tube**

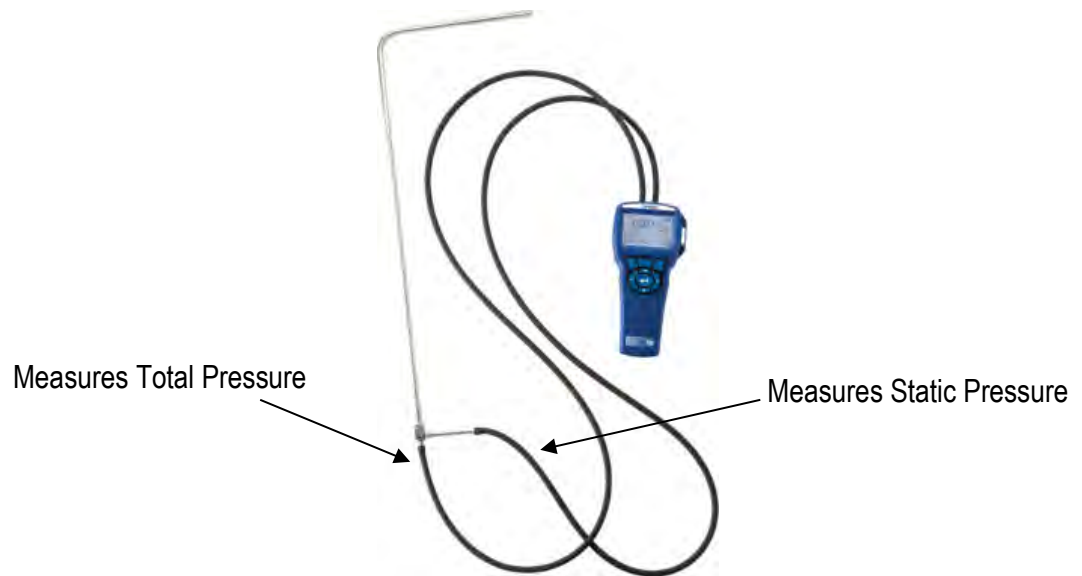

(Source: TSI Inc – reproduced with permission)

**Figure 6.30 – Pitot Tube with Digital Readout**

From the recorded velocity pressure ( $P_v$ ) the velocity of air moving through the system can be calculated from:

$$P_v = \rho \frac{v^2}{2}$$

$P_v$  = Velocity pressure

$\rho$  = Density of air

$v$  = Air velocity

Pitot tubes are useful in that they need no calibration if connected to a liquid filled manometer. However, when connected to a meter, this will require calibration. However measurements must be made in an area of ductwork where there are no obstructions, bends or turbulence. To achieve this it is common practice to take measurements in a straight section of duct at least 10 duct diameters from the nearest bend or obstruction.

Pitot tubes are generally not considered reliable to measure airflows with velocities less than  $3 \text{ ms}^{-1}$ .

Once the measurement instrument has been selected it is important to take the actual measurements in an appropriate manner so as to ensure accuracy. Because airflow can be influenced by bends, obstructions, etc and the fact that air close to the walls of the duct will move slower than in the centre (due to frictional forces), it is necessary to obtain an average velocity over the whole cross-section of the duct.

To obtain the average velocity the selected measurement area of duct must be divided into sections of equal area and a representative velocity measurement made in each. Most statutory authorities have specific requirements as to the number of sampling points that must be used for specific duct situations, however the ACGIH® (2007) provides the following general guidance.

- **Round Ducts**

- For ducts <15 cm a minimum of 6 points
- For ducts >15 cm a minimum of 10 points
- For very large ducts or where wide variation in velocity is present, a minimum of 20 points will provide a higher level of precision.

Wherever possible the pitot tube traverse should be made downstream at a point 7.5 duct diameters or greater from any major air flow disturbance (eg: elbow, hood). If measurements are made closer to disturbances the results must be considered doubtful and checked against a second location (must be within 10% to be considered acceptable).

A 10 point traverse of a duct greater than 15 cm is provided in Figure 6.31.

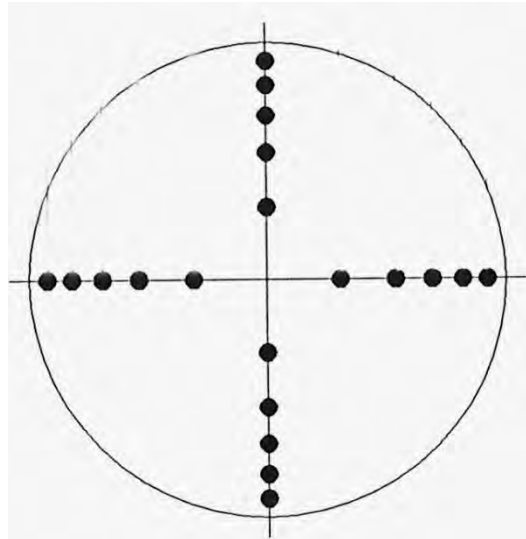

(Source: University of Wollongong)

**Figure 6.31 – Typical Ten Point Traverse in Round Duct**

- **Square or Rectangular Ducts**
  - Divide the duct cross-section into a number of equal rectangles and measure the velocity at the centre of each. The minimum number of points should be 16, however the maximum distance between each rectangle centre should be no greater than 15 cm
  - Once the average velocity is established this is multiplied by the duct area to give the airflow

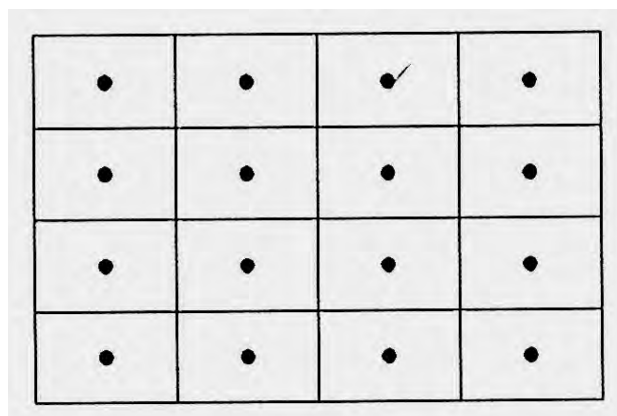

(Source: University of Wollongong)

**Figure 6.32 -Typical Traverse Points in a Rectangular Duct**

It is important to note that when taking velocity pressure measurements to measure air velocity, all velocity pressure measurements must be converted to velocity before taking the mean of all measurements.

## b) Pressure Measurements

Pressure within a system can be measured with simple “U” tube manometers where the difference in height between the two ends of the liquid column indicates the pressure. Most commercial manometers are calibrated in Pascals, however the pressure can be calculated using any manometer from the formula:

$$P = \rho_2 g h$$

Where:

- P = Pressure
- g = Acceleration due to gravity
- h = Height of column
- $\rho_2$  = Density of manometer liquid

Instrumentation that is more practical for use in the field can be commercially obtained. Routine measurement of static pressure can be an excellent indicator of problems.

Examples of how this can be used are provided in the HSE publication “Maintenance, examination and testing of local exhaust ventilation”. An example of the use of static pressure for fault-finding in a simple LEV system is provided in Figure 6.33.

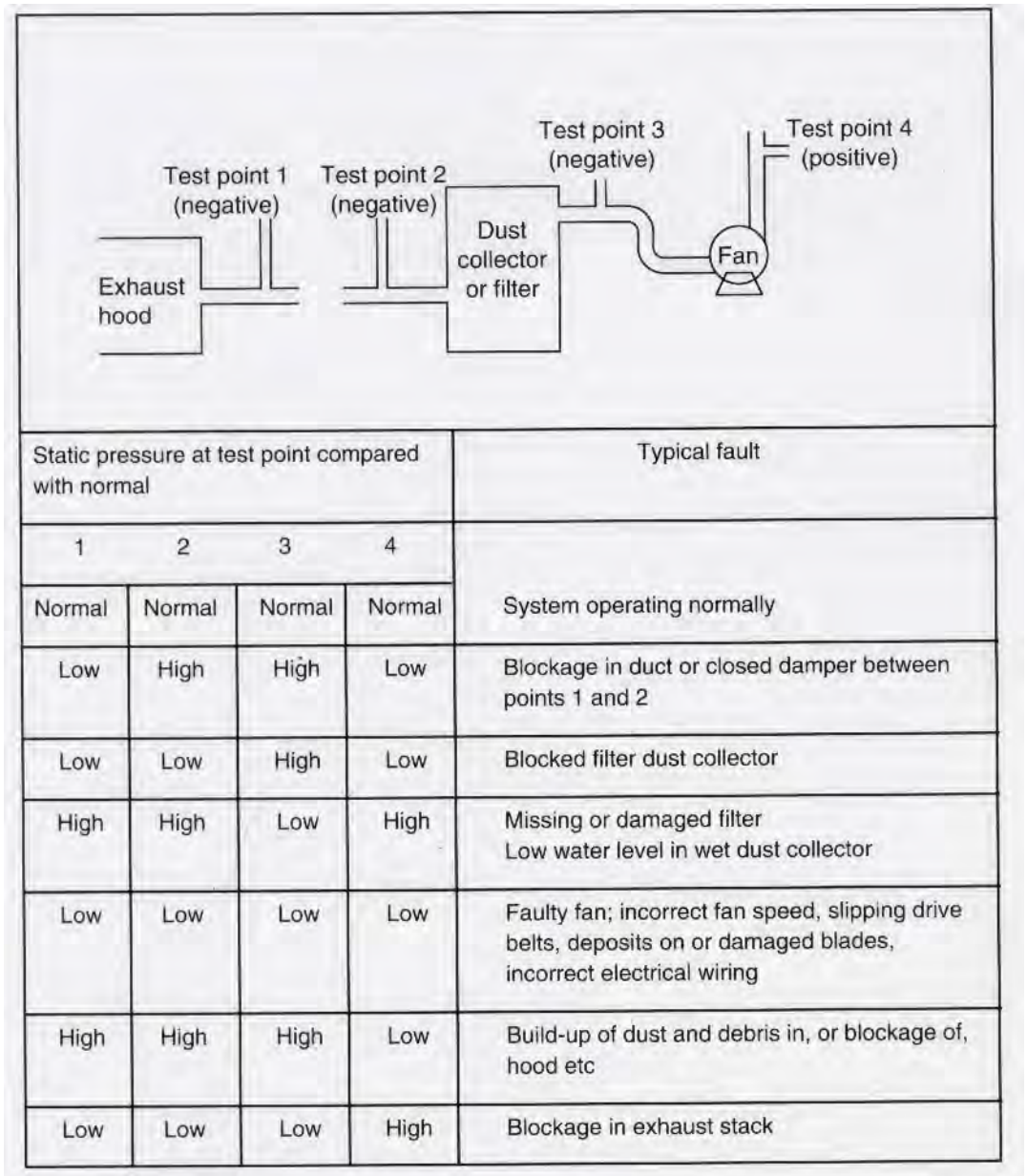

(Source: HSE – reproduced with permission)

**Figure 6.33 –Use of Static Pressure for Fault-Finding in LEV System**

**c) Air Movement**

Visualisation of air pathways and movement can be easily achieved via the use of smoke tubes. A chemical in these tubes reacts with moisture in the air to form a white smoke, which not only allows the visualisation of air movement but also its magnitude. Such devices are excellent for demonstrating the limitations of a hood in capturing contaminants or secondary airflows from behind the hood.

In dust-laden atmospheres the movement of particles can be highlighted with the simple dust lamp.

The dust lamp is based on the “Tyndall effect” discovered by John Tyndall in the mid 1800’s.

Essentially, a bright beam of light is shone through the area where it is thought a particle cloud may be present. The particles present diffract the incident light and an observer looking up the beam to the source of the illumination (at an angle of about 5 – 15°) can see the dust particles. The process is described schematically in Figure 6.34 and can be a powerful tool if linked to high speed photography or digital video equipment.

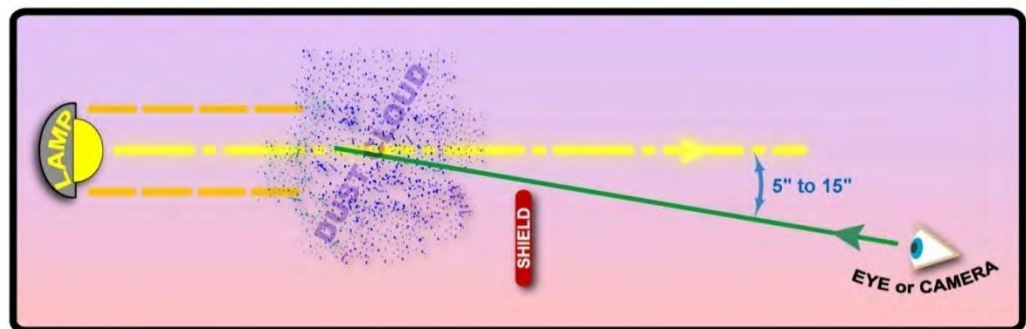

(Source: HSE – reproduced with permission)

**Figure 6.34 – Principle of the Dust Lamp**

This device has been included to demonstrate how a simple beam of light can be used to highlight dust clouds but as with most things some level of knowledge and skill is required to achieve good results.

Armed with the above instrumentation and subsequent measurements, it is possible to make an assessment of a LEV system.

While the requirements of evaluating LEV systems vary from one country to another, the HSE (2008) suggest that the carrying out of a thorough examination and test of a LEV system involves three stages.



These are:

- A thorough visual examination to verify the LEV is in efficient working order, in good repair and in a clean condition
- Measuring and examining the technical performance so as to check conformance with the original commissioning data
- Assessment to check the control of worker exposure is adequate (eg: smoke tubes, dust lamp, workplace monitoring)

The HSE (2008) recommends the following specific measurements:

- **Full Enclosures**  
Static pressure in the interior of enclosure must be lower than the workroom.
- **Partial Enclosures**  
Individual face velocity measurements should not vary by more than 20% from the average and also meet statutory or national standards.
- **Receiving Hoods**  
Individual face velocity measurements should not vary by more than 20% from the average. For larger hoods, measure at several points over the face.
- **Capturing Hoods**  
For slots, measure the air velocities at equidistant points along the slot and average the readings. Individual readings should not vary by more than 20% from the average.
- **Hood Ducts**  
Check the static pressure and compare to the normal value.
- **Plenums**  
Measure the static pressure of the plenum (enclosure behind some types of hood) and the hood duct.

- **Ducts**  
Measure air velocity in the duct serving each hood.
- **Fan**  
Measure the static pressure at the fan inlet and the volume flowrate.
- **Collection Devices**  
Where appropriate, measure the static pressure drop across the device and compare to normal conditions.

It should be appreciated that many of the measurements indicated above would not normally be taken by a site hygienist but should be incorporated into maintenance procedures which are then audited.

The time period for conducting a thorough examination and test is usually described in local or national legislation and reference should be made to that source for the appropriate information. In most cases periods of 12-15 months are not uncommon but some specific processes have much shorter periods (eg: blasting of metal castings for cleaning purposes is one month in the UK).

In between subsequent periods of thorough examination and test it is appropriate to implement routine appraisals and regular maintenance of the system. The HSE (2004) indicates that regular inspection and checks may include:

- Ensuring that the LEV is always running when hazardous substances are being emitted or are likely to be emitted
- Observing the condition of the suction inlet such as the hood, booth, etc to see whether it has moved or has been damaged
- Observing the condition of any visible ductwork and dampers by the inlet

- Observing any evidence of control failure, for example noticing if there are unusual dust deposits or a stronger odour than normal immediately outside the LEV
- Observing any local instrument that has been fitted to the LEV to show its performance, such as a pressure gauge on a filter or an airflow device on a fume cupboard
- Undertaking any minor servicing such as emptying filter bins

The results of all inspections and all test data should be recorded in a system log-book. This is a statutory requirement in many authorities.

#### **6.4.8 Limitations of LEV Systems**

While LEV is the preferred method of ventilation contaminant control, it, like other control strategies, has some issues which limit its acceptance or usefulness. Some such issues include:

- Need to be purpose designed for a process, making process changes difficult if the same level of control is to be maintained
- High capital and operating cost. All LEV systems require energy for the fan and for conditioning make up air, making operating costs an added expense
- High levels of noise are common with LEV system, resulting in them being turned off by operators in many cases
- Many are of a fixed structure design making flexibility within the workplace difficult
- Many require the installation of an air supply system. Supplied air may need to be heated in cold climates or during winter months in temperate climates
- Not practical for large disperse contaminant clouds that have multiple sources
- Limited application for the control of moving sources

## **6.5 GENERAL VENTILATION SYSTEMS**

### **6.5.1 Dilution Ventilation**

Dilution ventilation (general exhaust ventilation in some countries) is in essence the dilution of contaminated air with sufficient uncontaminated air so as to reduce the concentration of contaminants to acceptable levels.

Dilution ventilation provides a lower level of control for health hazards than can be achieved by the use of local exhaust ventilation. It has been suggested (AIOH 2007) that dilution ventilation may be appropriate when:

- The air contaminant has low toxicity
- There are multiple sources
- The emission is continuous
- The concentrations are close to or lower than the occupational exposure limit
- The volume of air needed is manageable
- The contaminants can be sufficiently diluted before inhalation
- Comfort or odour is an issue
- A spill has occurred and extended airing of the workplace is needed

Dilution ventilation is not likely to be effective in the following situations

- In processes that generate high levels of contaminants
- In processes where the generated contaminant has a high toxicity
- In processes where the generation of the contaminant varies widely (ie: low to very high)

Dilution ventilation can be either forced (mechanical means to achieve air movement) or natural. If natural airflows are used to achieve dilution of contaminants to the required level, factors such as wind direction, wind speed and air temperatures are likely to influence the effectiveness of the process.

It is important to remember that if sole reliance is placed upon natural ventilation, little or no control will be achieved on days when there is no wind or if it blows from the wrong direction.

### 6.5.2 Dilution Ventilation Equations

Dilution ventilation of contaminated air can be visualised by pouring clean water (clean air) into a container of coloured water (contaminated air). If the added clean water does not mix with the coloured water then the colour of the water (contaminant) persists and the container merely overflows. However, if the container is mixed during the addition of the clean water it still overflows but the colour fades.

Using this principle it is possible to apply a mathematical approach to the dilution process which allows airflow rates necessary to reduce worker exposures to be estimated.

If we consider a constant emission source, perfect mixing and a constant airflow, the following equation represents the equilibrium concentration in a ventilated space (eg: a room).

$$Q = \frac{r}{C}$$

Where  $Q$  = Airflow rate in  $\text{m}^3\text{s}^{-1}$

$r$  = Emission rate in  $\text{mgs}^{-1}$

$C$  = Equilibrium concentration in  $\text{mgm}^{-3}$

Thus it is possible to use this equation to calculate the airflow rate to reduce the potential worker exposure to the exposure standard (or some fraction of the OEC) provided we know the emission rate. Unfortunately the value of  $r$  is difficult to establish as it has to be based on the amount of pollutant released into the atmosphere. This depends on the consumption of the source material and release rate.

Another approach is to consider the decay in contaminant concentration with time. This can be represented as:

$$C = C_0 e^{-Rt}$$

Where  $C_0$  = Initial contamination concentration (ppm)

$R$  = Ventilation rate  $\left(\frac{Q}{V}\right)$

$Q$  = Airflow ( $\text{m}^3 \text{s}^{-1}$ )

$V$  = Volume of ventilated space ( $\text{m}^3$ )

$t$  = Time (s)

This formula describes the reduction in contaminant concentration overtime and can be shown to be an exponential decrease (Figure 6.35).

If we consider a room of  $10 \text{ m}^3$  with an initial contaminant concentration of 1,000 ppm and a diluting airflow of  $0.1 \text{ m}^3 \text{ s}^{-1}$ , the concentration in the room after 10 minutes would be 2.5 ppm (complete mixing).

Thus, in this example we are able to predict that in a room  $10 \text{ m}^3$  and a diluting airflow of  $0.1 \text{ m}^3 \text{ s}^{-1}$  the concentration would be a small fraction of what it was originally in only 10 minutes.

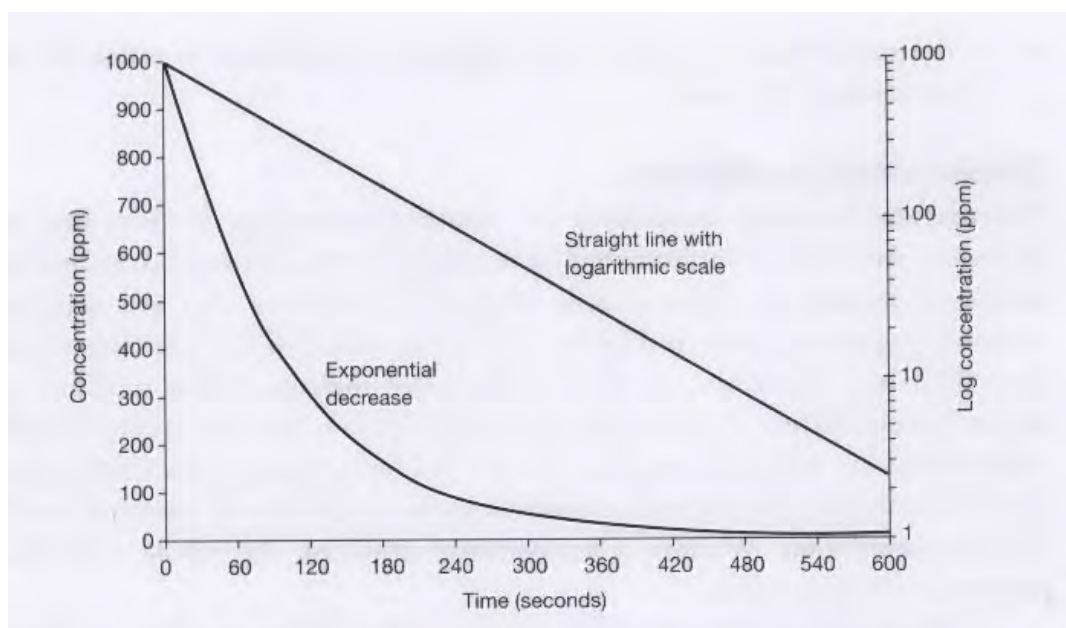

(Source: AIOH 2007 – reproduced with permission)

**Figure 6.35 – Contaminant Decay With Dilution Ventilation**

This example calculation is misleading and would most probably underestimate the final concentration due to incomplete mixing. To overcome this issue it is common to apply a factor “K” which can range from 1.0 to 10.

The “K” value is somewhat arbitrary and according to the ACGIH® (ACGIH® 2009) is based on:

- The efficiency of mixing and distribution of replacement air
- Toxicity of the solvent
- A judgement by the occupational hygienist as to any other circumstance of importance

Thus the two dilution equations become:

$$Q = \left(\frac{r}{C}\right) k$$

$$C = C_0 e^{-\frac{Rt}{k}}$$

For a particular substance, if the rate of evaporation ( $\text{mg s}^{-1}$ ) and density ( $\text{kg m}^{-3}$ ) is known, the quantity of air needed to reduce the vapour concentration to the exposure standard (ppm) can be calculated by the formula:

$$Q = \frac{\text{Rate of Evaporation}}{\text{Density} \times \text{Exposure Standard}}$$

This equation does not take account of mixing and thus a suitable K factor must be applied.

### 6.5.3 Infiltration

Infiltration occurs when air is drawn into a building through vents and unintentional openings. This process may adversely affect the general extraction ventilation system by drawing in air polluted with unwanted contaminants or changing the airflow direction so that adequate dilution of the prime contaminant source does not occur.

### 6.5.4 Application of Dilution Ventilation Systems

The AIHA (2003) suggests that dilution ventilation systems can be effective when:

- Major air contaminants are of relatively low toxicity
- Contaminant concentrations are not hazardous
- Smoking is not allowed in the occupied space
- Emission sources are difficult or expensive to remove
- Emissions occur uniformly in time
- Emission sources are widely dispersed
- Emissions do not occur close to the breathing zone of people
- Moderate climatic conditions prevail
- The outside air is less contaminated than the inside air
- The HVAC system is capable of conditioning the dilution air

The AIOH (2007) has a similar approach and their recommendations for use are when:

- The air contaminant has low toxicity
- There are multiple sources
- The emission is continuous
- The concentrations are close to or lower than the occupational exposure limit
- The volume of air needed is manageable
- The contaminants can be sufficiently diluted before inhalation
- Comfort (or odour) is the issue (in the absence of other contaminants)
- A spill has occurred and extended airing of the workspace is needed

Gardiner & Harrington (2005) state that “This method of ventilation is less positive than extraction and should only be used when extraction ventilation is not practicable; the pollutants have a low toxicity and the release volume does not fluctuate.”



This represents sound guidance and should be remembered when considering which ventilation system to select for a workplace.

### 6.5.5 Displacement Ventilation

Displacement ventilation (or more correctly thermal displacement ventilation) is not used widely for the control of hazardous substances. However, it can often be found in heavy industrial plants, such as steelworks, where there are large high temperature sources of contamination. In this process, the buoyant plume rises to the roofspace and new slightly cooler air is introduced to the workplace near floor leaving the workers in a clean atmosphere.

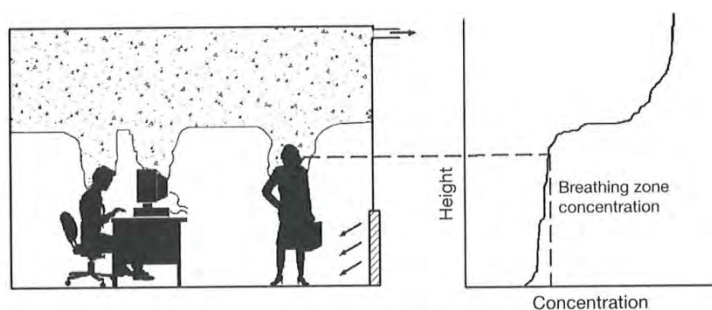

(Source: AIOH 2007 - reproduced with permission)

**Figure 6.36 – Thermal Displacement Ventilation**

An industrial application of this principle can be seen in Figure 6.37.



(Source: Photograph copyright of Colt International Licensing Limited)

**Figure 6.37 - Application of Thermal Displacement**

It is interesting to note that displacement ventilation can be much more efficient than dilution ventilation. For displacement ventilation to work effectively the ceiling height needs to be relatively high (3 m).

The AIOH (2007) indicates that displacement ventilation works best when:

- The contaminants are warmer than the surrounding air
- The supply air is slightly cooler than the surrounding air
- The room is relatively tall (>3 m)
- There is limited movement in the room

While displacement ventilation is not common in many countries, it is routinely practiced in northern European countries.

#### **6.5.6 Limitations of General Ventilation Systems**

While general ventilation is routinely practiced as a means of contaminant control, there are a number of limitations which should be considered when selecting a ventilation system for a workplace. These include:

- Exhausting a volume of air equal to the capacity of the workplace area does not ensure that all air in the area has been changed once, because air in the centre of the pathway between inlets and exhaust vents moves well and is changed more than once, whereas air in corners and off to the side may be relatively stagnant. The source of a hazardous contaminant may be away from the path of direct and optimal flow of air through the facility and thus contaminant levels may remain elevated
- Air carrying a hazardous substance may be moved toward the worker or past several other workstations on its way to be exhausted, increasing general exposure to the contaminant
- Processes that release larger amounts of material for a short time, and very little between times demand a high level of air movement during the short time of release

Unfortunately, the time that the contaminant is being released usually coincides with a worker being at the site and general exhaust systems cannot adapt to such high concentration situations

- Seasonal reductions in the ventilation rate may reduce air flow in hazardous areas below desirable rates
- A loss of efficiency may occur as a system ages or between times of routine maintenance as ducts or filter become blocked with dust or fan belts slips
- The airflow calculations assume the entering air is clean, high-quality air and so does not contribute to contamination of the room air. This is often not the case

The AIHA (2003) considers dilution ventilation to be less effective and more expensive in the following situations:

- Air contaminants are highly toxic materials
- Contaminant concentrations are hazardous
- Smoking is allowed in the occupied space
- Emission sources are easy to remove
- Emissions vary with time
- Emission sources consist of large point sources
- People's breathing zones are in the immediate vicinity of emission sources (ie: less than 1 m)
- The building is located in severe climates
- The outside air is more contaminated than the inside air
- The existing HVAC system is not capable of treating the air

One other factor must be considered, however it rarely achieves the level of importance that it should. This occurs when there is a process change in the workplace.

The introduction of new or larger sources of chemicals or particulates may create hazards the previously satisfactory system cannot now handle. A new process may include a substance whose airborne concentrations must be held to lower levels than those previously in use. Even without a change in chemicals or in total level of output into plant air, problems arise if the process change abandons a steady moderate rate of emission in favour of intermittent larger releases. Rearranging the locations of workers to suit the new process could result in exposure to harmful materials by people previously out of their path.

During a period of change often the focus is on improving the cost and efficiency of the process and it is important that such driving forces are tempered with a scientific assessment of such changes in the workplace. This must, but often doesn't, include ventilation systems.

## 7. PRINCIPLES OF CONTAINMENT

### 7.1 INTRODUCTION

#### 7.1.1 Definition of Containment

The terms “containment”, “isolation” and “segregation” are often used interchangeably to describe the equipment, systems or procedures which are employed to prevent or reduce exposure to hazardous substances. In this instance the term containment will be used to describe any control measure which reduces exposure by using a barrier to prevent the escape of materials hazardous to health into the surrounding workplace.

It is worth noting that containment may also be used as a product quality control. ie: containment can be used to prevent contamination or degradation of compounds by the environment; eg: during electronic components or pharmaceuticals manufacture where a controlled manufacturing environment is required (Figure 7.1).

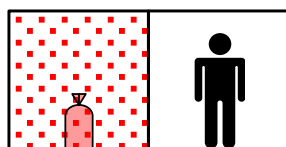

Containment as exposure control

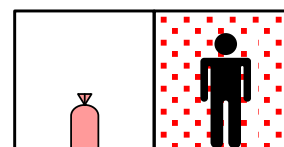

Containment as process control

(Source: Adrian Hirst – reproduced with permission)

**Figure 7.1**

When designing or assessing containment it is important to take into account the product quality control as well as the exposure control as in some instances the two aims may contradict each other. For example where clean room technology is used, containment is augmented by ventilation to achieve pressure differentials. These pressure differentials may be used to contain either the substance or the environment but not both.

### 7.1.2 Use of Containment

Containment is used in manufacturing industries, particularly those handling and producing chemicals; eg: chemical manufacture, agrochemicals, pharmaceuticals, petrochemical industry.

Containment tends to be used as a control measure to reduce the level of risk from the following hazards:

- Flammability
- Explosivity
- Toxicity

### 7.1.3 Primary and Secondary Containment

In some instances it may be useful to classify containment into two different types depending upon their function.

**Primary containment** may be defined as the first level of containment, that is, the inside portion of the container that comes into immediate contact on its inner surface with the material being contained.

**Secondary containment** is a control measure to prevent unplanned releases of toxic or hazardous compounds into uncontrolled work areas. As such this is a level of containment that is external to and separate from primary containment.

At a simple level an example of primary containment is the use of an intermediate bulk container (IBC) or sealed drum to contain a liquid, whilst secondary containment is use of a bund or drip tray to capture any releases from the drums/IBC.

### 7.1.4 Integration of Containment With Other Control Measures

All control measures need to integrate with each other so they work in an additive or synergistic way rather than an antagonistic one. This is particularly important with regards to containment solutions.

An understanding of how other controls measures work is important at the design stage. In particular containment is often designed to incorporate ventilation as a control measure. It is essential that the containment designers have a good working knowledge of general and local exhaust ventilation in order to combine the two. Similarly operation of containment controls will require a significant amount of administrative control in terms of working practices, information, instruction and training.

Containment devices can be broadly classified into two types depending upon the mode of operation:

- **Barrier devices:** This is where one or more barriers are placed between operator and exposure source. For example mixing of chemicals is carried out within a sealed vessel.
- **Combined barrier-LEV devices:** This is where the use of barriers/enclosures is combined with LEV controls; eg: a laboratory fume cupboard with an adjustable sash height. The use of LEV to maintain containment by creating negative pressures is especially important.

### 7.1.5 Integration of Containment With Process Design

In many instances it is appropriate to integrate the design of containment with that of the process and as such the containment will influence the design of the process. Containment is much more difficult to apply as an add-on control measure than it is when considered at the start up stage. For instance the inclusion of screw feed conveyors and gravity feed is as much about the process as it is containment.

### 7.1.6 Typical Industrial Processes Requiring Containment

The manufacture of chemicals may involve a significant number of the following processes.

- Weighing/dispensing of solid raw materials
- The addition of solid/liquid and /or gaseous reagents to reaction vessels

- The controlled reaction of chemicals with subsequent product and by product generation
- Purification steps which may involve the addition and removal of materials
- Crystallisation of a solid product
- Separation of products from liquors
- Drying
- Removal of the product to containers
- Milling and Blending

The scale and nature of these operations will vary depending upon the product but they are used in various forms to manufacture a wide range of materials whether it is paint, soap powder or food.

- Transfer operations involving solids
  - Dispensing operations
  - Charging of vessels and equipment
  - Unloading solid-liquid separation equipment
  - Unloading dryers
  - Milling and Blending
  - Removal of solid impurities
- Transfer operations involving liquids
  - Loading and unloading of road/rail tankers
  - Drum and semi bulk container transfers
  - Small container transfers
  - Pressurised liquid transfers from cylinders
  - Container filling
- Gaseous transfers
- Quality control sampling
- Process containment
- Plant cleaning



## 7.2 TYPES OF CONTAINMENT EQUIPMENT

### 7.2.1 Simple Enclosures and Screens

At the simplest level containment is used for the storage of hazardous substances. Enclosing substances with sealed containers can prevent or minimise releases into the workplace (Figure 7.2). Examples of this kind of containment include; the use of lids and specialized containers and dispensers such as plunger cans.

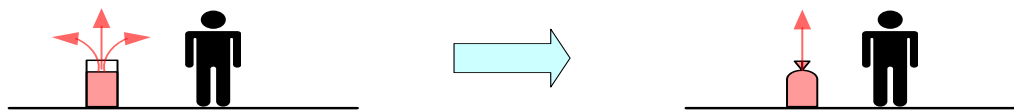

(Source: Adrian Hirst – reproduced with permission)

**Figure 7.2**

The use of a simple but incomplete barrier between the operator and the substance can also act as containment. This barrier also has the effect of influencing the operator's behaviour and preventing them from undertaking certain activities which might increase their exposure (Figure 7.3).

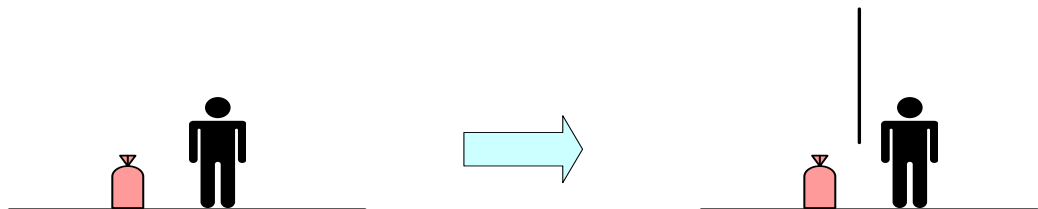

(Source: Adrian Hirst – reproduced with permission)

**Figure 7.3**

This type of containment can be combined with Local Exhaust Ventilation to enhance the effects of both types of control (Figure 7.4). The barrier acts to control the direction of the airflow. Examples of this kind of containment include; the sash in a laboratory fume cupboard or the use of “salad bars” in powder weighing/dispensing.

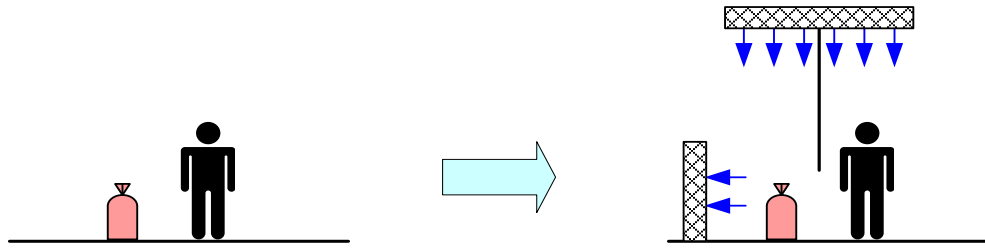

(Source: Adrian Hirst – reproduced with permission)

**Figure 7.4**

Segregation of substances and activities either by distance or physical containment can also reduce exposures by virtue of the fact that less people are exposed (Figure 7.5). An example of this kind of containment is the separation of different activities (welding, painting etc) in general manufacturing.

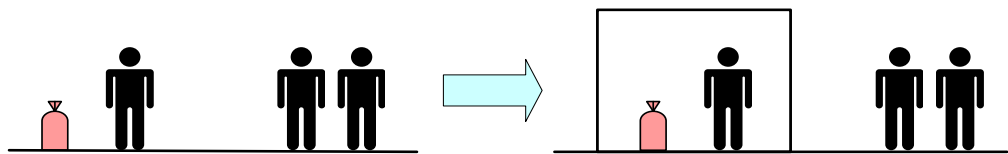

(Source: Adrian Hirst – reproduced with permission)

**Figure 7.5**

### 7.2.2 Isolators

An Isolator is any localised environment created by a sealed enclosure in order to achieve containment (Figure 7.6). For the purposes of this introduction to workplace controls it may be useful to consider an isolator a device similar to a glove box. Isolators are used in biological laboratories, the nuclear industry and the pharmaceutical industry or anywhere which requires a high level of containment. Isolators come in a wide range of designs and may be rigid structures composed of stainless steel and glass or may be simple flexible plastic units.

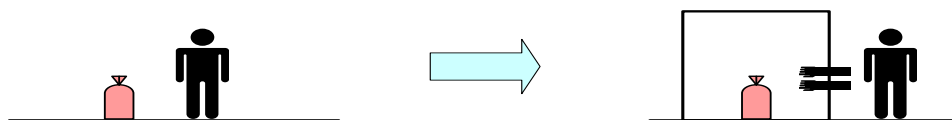

(Source: Adrian Hirst – reproduced with permission)

**Figure 7.6**

### 7.2.3 Over-bagging

The wrapping or double bagging of materials for storage or transport purposes provides a higher degree of primary containment as well as a degree of secondary containment (Figure 7.7). An example of this kind of containment is employed during the removal of asbestos where waste materials are double wrapped, with the outer layer being clear plastic which facilitates inspection of the integrity of the containment achieved.

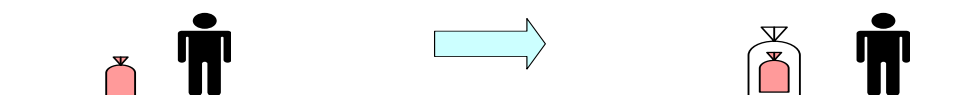

(Source: Adrian Hirst – reproduced with permission)

**Figure 7.7**

### 7.2.4 Transfer Devices

Whilst devices like isolators are useful for undertaking reactions or carrying out specific activities the materials will need to be transferred into and/or out of them and other devices. The use of vacuum transfer techniques or direct pipelines and screw conveyors represent ways of achieving containment whilst transferring materials (Figure 7.8). An example of this kind of containment is the transfer of flour in food factory using a blowing device to send it along a pipe to a dispensing hopper.

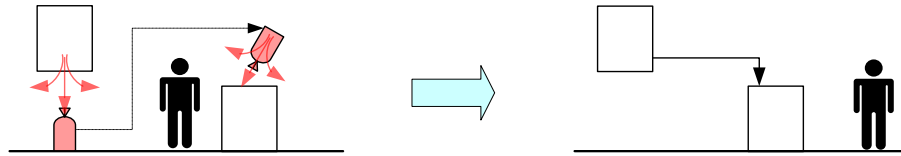

(Source: Adrian Hirst – reproduced with permission)

**Figure 7.8**

### 7.2.5 Coupling Devices

Another containment technique used in the transfer of materials is the use of coupling devices where sealed containers are linked directly with the devices from which they are filled or emptied. This technique allows materials to be stored in intermediate containers rather than it them having to be transferred directly. Coupling devices may be simple gravity fed chutes or more complicated engineering devices such as split butterfly valves (Figure 7.9). An example of this kind of containment is the bottles used for photocopier toner or the use of IBCs for applications such as polyurethane foam manufacture.

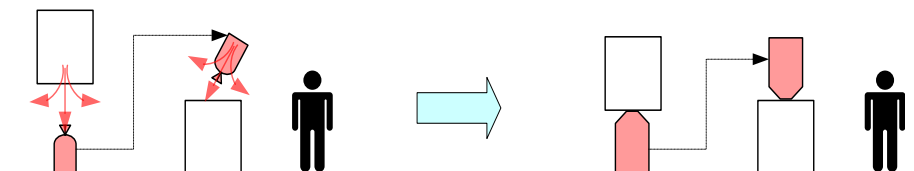

(Source: Adrian Hirst – reproduced with permission)

**Figure 7.9**

### 7.2.6 Remote Handling

Where the level of containment needs to be at a maximum, then enclosures can be used to incorporate the whole process and the activity is carried out remotely by automated devices (Figure 7.10). This kind of containment is used in the nuclear industry.

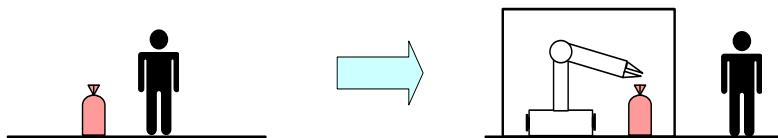

(Source: Adrian Hirst – reproduced with permission)

**Figure 7.10**

### 7.3 DESIGN OF CONTAINMENT SYSTEMS

The effective design and implementation of containment control measures requires a thorough understanding of the hazardous substances involved and the processes which they are used in. Since there is a strong interaction between the use of containment with LEV as well as ergonomic issues it is often good practice to use mock ups of containment at the design stage.

The use of models and full size mock ups, as well as computer 3D imagery, allow employers to assess whether the ergonomic requirements of a task are being met. For instance the some of the example photos shown at the end of this section would have been difficult to produce without first producing mock-ups.

Full size mock ups from cheap and flexible materials can also be a useful aid to assessing the efficacy of an LEV design.

The use of a control banding approach is often adopted to determine the level of containment that is required.

#### 7.3.1 High Level Containment Systems

High levels of containment tend to be used when potent materials are used which have low exposure limits or where larger quantities of more dusty/volatile materials are present. For example the storage of flammable liquids in the oil industry normally requires a high level of containment as does work in biological laboratories and the nuclear industry. High level containment requires careful design and precision in the engineering.

The level of containment achieved at this level is refined by using increasingly more complex forms of engineering. For instance, Figure 7.11 shows three different levels of containment used for shutting off the supply of powder when filling containers by gravity feed. At the first stage a simple butterfly valve cuts off the gravity feed of powder from above. This prevents mass leakage of the material but leaves the container open some residue at the mouth of the butterfly valve.

At the second stage the container is physically connected to the dispensing unit and a split butterfly valve is fitted. The split butterfly valve seals both the supply and the container but leaves the possibility that small quantities of material are left at the point where the two valves meet. At the third stage a split butterfly valve is used but a compressed air supply is also used to blow residue off the valve before it is closed.

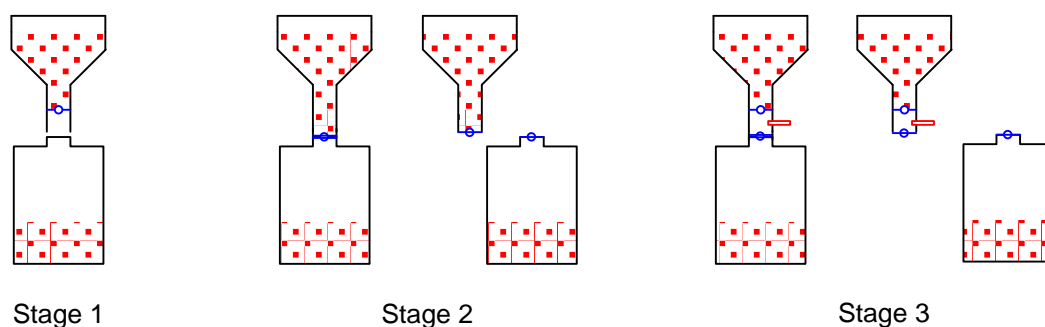

(Source: Adrian Hirst – reproduced with permission)

**Figure 7.11**

The types of equipment used in high level containment facilities include the following:

- **Isolators:** Sealed enclosures in which the hazardous substance is enclosed whilst work is carried out on it.
- **Clean room technology:** - Rooms provided with filtered air to maintain aseptic conditions, ensure adequate general ventilation as well as limit transfer of materials from and into adjacent areas.

- **In process cleaning:** Washing and cleaning facilities which allow the equipment to be cleaned quickly and easily in situ.
- **In process maintenance:** Designs which allow activities such as glove or filter changing on an isolator to be carried out without having to clean and dismantle the whole apparatus.
- **Split butterfly valves:** Sealing systems which minimise deposits on surfaces after components are taken apart.
- **Docking systems:** Direct coupling devices which are specifically designed to link to the next stage of the process.
- **Pass Boxes:** Antechambers to isolators which allow controlled conditions for materials to enter and exit the isolator. A pass box typically consists of two doors, one into the workplace and one into the isolator. The doors are interlocked preventing both from opening and the antechamber itself is extracted.

## 7.4 OTHER CONSIDERATIONS

### 7.4.1 Control of Waste and Emissions

Any materials which are removed from a containment system, whether they are products or waste products have the potential to be contaminated with hazardous materials. Any form of containment will therefore require appropriate consideration to be given to the treatment of materials as they are removed from it.

**Wastes from containment systems:** Empty bags, drums and liners etc will contain traces of the materials which were held within them. The handling of these materials can give rise to significant exposures eg: the rolling of an empty bag for disposal.

**Containment of filter elements and media:** It will be necessary to change consumable items such as filter media which will then need to be disposed of. This can result in exposure as well as a temporary failure of the containment system.

**Contaminated clothing:** Clothing and other forms of PPE/RPE may be contaminated and will require specific controls in order to ensure their safe handling, cleaning and/or disposal.

**Exhaust gases containing hazardous vapours or particulates:** These may be generated by the process or induced as part of the containment equipment. The subsequent cleaning and discharge of the gases will need to be considered. Where high levels of containment are needed then the level of filtration will need to be high; eg: use of HEPA filtration on isolators in the pharmaceutical industry.

**Contaminated drainage and cleaning liquids:** Liquids will invariably need to be used for cleaning purposes. These pose very different considerations when it comes to potential exposure and eventual disposal.

#### **7.4.2 Explosion Prevention and Control**

The build up of high concentrations of dust, flammable gases and vapours can give rise to the potential of explosion. The act of containment means that substances are held in a smaller space which in turn means the localised concentrations are higher. This means that introducing the concept of containment can increase the likelihood as well as severity of explosion.

It is beyond the scope of this course to give details about the design of plant and equipment for the prevention and control of explosions. However, whenever it should be recognised that when containment is introduced as a control measure then the effective prevention and control of potential explosions should be considered.

The design of any containment system which involves potentially explosive atmospheres should incorporate design features which prevent the occurrence of an explosion as well as mitigate the effects in the event of one taking place.



**Explosion prevention:** This may be achieved using a variety of techniques such as:

- The elimination of ignition sources: electrical sources, heat, static electricity etc
- The prevention of explosive concentrations

**Mitigation measures:** This is achieved using techniques such as:

- Explosion suppression – the use of sensors and fire extinguishants to react quickly and put out explosions as they start
- Compartmentalisation – the division of a containment into smaller units to prevent the spread of an explosion to other parts of the system

#### **7.4.3 Operation and Maintenance of Containment Devices**

As with all forms of exposure control the correct operation and maintenance of containment devices is essential if they are to be effective

- Information, instruction and training on correct use of device - Operating procedures
- Regular checks and thorough examination. In the UK the COSHH regulations require that all forms of control measure are inspected and tested on a regular basis
- The maintenance and repair of containment devices may present greater potential for exposure than their actual use. The cleaning of devices and activities such as changing consumable parts should be considered at the design stage as much as the normal operation of the devices. All maintenance personnel must be protected during any process which may expose them to contaminants. This may involve the short term use of personnel protective equipment

#### **7.4.4 Limitations of Containment Systems**

Containment systems have inherent weaknesses which stem from the nature of their design.

**Transfer points:** Wherever material is moved from, into or around a containment system there is the potential for the release of hazardous substances. In many cases the transfer points have to be specially designed to minimise the release of hazardous substances.

**Seals:** Joints in containment systems have the potential to leak. Leaks may occur as a result of breakdown of the material or due to poor design or contamination during use.

**Cleaning:** The design of containment systems means that they both need cleaning and at the same time become difficult to clean. In some instances this is overcome by the installation of in-process cleaning facilities.

**Quality Assurance Sampling:** The requirement to take away samples of material for QA purposes can present particular problems. Firstly the containment may need to be broken in order to collect the sample. Secondly, the sample obtained needs to be contained whilst it is subject to the QA testing.

**Ergonomic Issues:** The use of containment can severely limit the way in which work is done and as such the efficiency with which it is done. For instance undertaking weighing work within an isolator rather than on an open bench or extraction booth could easily double or treble the amount of time required.

#### 7.4.5 Future Developments

There are a number of factors which mean that in the future containment is likely to become an increasingly important method of controlling exposure.

- The trend of continually reducing exposures as legislative requirements become more stringent means that containment will need to be used instead of less effective or less desirable methods of control; eg: reducing reliance on RPE

- The development of more potent compounds in the pharmaceutical and chemical industries means that improved levels of control will be required as active ingredients are developed which have lower exposure limits
- The emergence and growth of nanotechnology presents a new array of hazards which can only be confidently controlled by using containment

## 7.5 TESTING AND VALIDATION OF CONTAINMENT

It is important to ensure that any control measure which is introduced is working effectively. The act of demonstrating the efficacy of a containment solution is termed “Validation” and consists of the visual examination of the controls as well as undertaking objective tests such as air monitoring, leak testing and the use of dust lamps.

Specific validation may be required for a number of reasons:

- It may not be possible to visually determine that containment is effective  
eg: where potent compounds with low OELs are used  
eg: Pharmaceutical industry
- Containment may need to be validated to ensure that it is protecting the product (process control) as well of the operator (exposure control)

The type and extent of any validation tests will vary depending upon the nature of the substances involved and the level of containment which is hoped to be achieved. At a simple level the assessment of simple containment devices can be achieved using qualitative assessments. When trying to verify containment on devices which control highly potent compounds with very low exposure limits then more detailed and specific test may be required. For instance measurements may need to be as sensitive as 5 nanograms/m<sup>3</sup>. This is the equivalent of one grain of pollen in an average-sized living room.

An example of a detailed containment validation technique is that described in the SMEPAC guidelines (Standardised Measurement of Equipment Particulate Airborne Concentration). This involves taking static air samples at the all the possible emission points in a containment system. The results from the individual emission points are then summed to produce an estimated of the release from the whole system.

It is common in many industries to conduct Factory Acceptance Testing (FAT) and Site Acceptance Testing (SAT). The protocols for this vary depending on what has been agreed between the customer and the supplier but normally contain a host of tests for which both parties have agreed specific standards.

The Factory Acceptance Testing (FAT) is normally the first stage of the acceptance process and involves a series of tests on the equipment at the supplier's premises.

Site Acceptance Testing (SAT) is undertaken in situ at the customer's premises after/during the equipments installation.

Both FAT and SAT tests will normally cover production quality and efficacy issues as well as the assessment of containment. Test may be undertaken on normal/typical operating conditions or may be carried out under worst case conditions.

## **7.6 SOME SPECIFIC EXAMPLES OF CONTAINMENT**

The following are some specific examples of containment which are used in different industries.

### **Petrochemical Industry examples**

Bulk petrochemical chemicals will invariably be handled in a chemical plant of a high integrity that is designed to minimise potential for emissions to air and water.

Typical examples of control measures and systems in place to deliver such strictly controlled conditions include:

- Enclosed transfers designed to prevent leaks eg: self-draining transfer lines
- High integrity methods of material loading and unloading (eg: dry break couplings, vapour capture and recovery)
- Plant designed to facilitate the draining and flushing of plant equipment items prior to maintenance, with recycle and/or suitable disposal of wastes
- High integrity (low emission) valve packings and flange seals
- In-line process controls and/or contained systems for process sampling
- Low emission pumps eg: canned, magnetic, mechanical seals
- Routine monitoring and inspection for leaks to reduce fugitive emissions

On your next visit to a petrol station have a look for the kind of containment controls that exist, here are a few examples:

- The fuel filler nozzle fits your car and has a device to cut off the delivery when it is full
- There is a sheath around the top of the nozzle which helps to reduce splash back and disperse vapours
- The underground storage tanks have linked tanks and are fitted with filters to equalize pressures and reduce emissions as they are filled and emptied

### **Fine Chemicals Industry examples**

Handling chemicals in batch fine chemicals facilities will require that the plant engineering and systems are designed to minimise potential for emissions to air and water.

Typical examples of control measures and systems which might be encountered to deliver such strictly controlled conditions include:

- Material transfers via enclosed systems (eg: semi-bulk containers such as IBCs)
- Enclosed and vented charging systems (eg: bag slitters with integral package disposal)
- Discharging arrangements designed to minimise emissions (eg: into drums/kegs via pneumatic filling heads and continuous liners; vented booths with exhaust scrubbing)
- Plant designed to facilitate the draining and flushing (and detoxification) of equipment items prior to maintenance
- Maximal use made of automated process control systems to minimise manual interventions
- Contained process sample systems (eg: vented cabinets or sample bombs)

### **Pharmaceutical Industry examples**

Transfers of pharmaceutically active powders typically use direct coupling and closed systems, sometimes combined with the use of unidirectional airflow booths. Examples include:

- Engineered Airflow Device
- Ventilated enclosures eg: laminar flow/powder containment booth
- Vertical process trains, with materials flowing under gravity in enclosed plant
- Specialised valving such as split butterfly valves
- Vacuum transfer of materials
- Intermediate bulk containers

For very potent materials, totally enclosed processes are needed. Examples include:

- Isolation technology (eg: glove boxes, “isolators”)
- Soft Wall Isolators (glove bags)

The following photographs illustrate some of the controls used in the pharmaceutical industry.



(Source: GSK – reproduced with permission)

**Figure 7.12**

Figure 7.12 shows a setup for dispensing and weighing of potent compounds. At the far end of the room is a downflow booth with clean air flowing down from the white panels in the ceiling. The air is then extracted at ground level via the stainless steel panels.

A clear plastic sheet with integral gloves forms containment which augments the downflow booth.

The stainless steel isolator in the foreground allows a higher degree of containment for weighing and mixing smaller quantities.

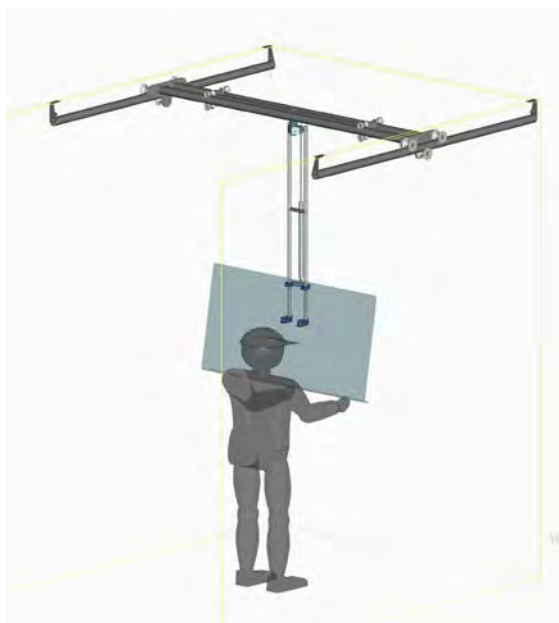

(Source: GSK – reproduced with permission)

**Figure 7.13**

Figure 7.13 shows a computer aided design diagram of a moveable screen. The screen can be used during dispensing and weighing activities and represents a simple form of barrier containment. The screen is intended to be fitted within a down flow booth and can be moved from side to side as well as up and down to achieve control and access.



(Source: GSK – reproduced with permission)

**Figure 7.14**



Figure 7.14 shows a product packaging facility that uses containment. Product is offloaded from a dryer, via screw conveyor. It is then transferred to a “Big Bag”. A “STOTT” (inflatable tyre) offload system ensures that there is a seal around the entry to the bag. The bag is situated inside a plastic “Megabin”. The Megabin is situated inside an extracted booth. The unit is operated from a control panel adjacent to, but outside, the ventilated booth.



(Source: GSK – reproduced with permission)

**Figure 7.15**

Figure 7.15 shows a typical isolator. The work is carried out within the chamber in the middle of the unit with access being achieved via the glove ports.

Note the pressure gauges at the top of the unit which indicate whether the correct negative pressure is being achieved.



(Source: GSK – reproduced with permission)

**Figure 7.16**

Figure 7.16 shows a half suit isolator. The clear Perspex cabinet provides containment of the activity with the operator gaining access from below. The use of a half suit allows good access for the operator.

Materials can be transported into and out of the device using the flexible plastic liner on the circular port on the side.

The unit is maintained under negative pressure by the fan and filtration system underneath. The system is also portable and can be moved to different areas.



(Source: GSK – reproduced with permission)

**Figure 7.17**

Figure 7.17 shows a simple form of containment which has been manufactured in-house using clear plastic sheeting and adhesive tape.

The provision of access ports allows the operator to open and close the lid of the container without releasing too much of the material. In this case short term access to the vessels is required to scrape away material which accumulates on the lid.



(Source: GSK – reproduced with permission)

**Figure 7.18**

Figure 7.18 shows a bag filling unit where powders are dispensed from above into a clear plastic bag. A tight seal is achieved on the bag using an inflatable seal (the white band in the middle of the picture). This is inflated with compressed air before powder is dispensed.

Further containment is achieved by the three sides to the chamber, which is augmented by the extraction at the rear.



(Source: GSK – reproduced with permission)

**Figure 7.19**

Figure 7.19 shows another way of decanting products into plastic bags - this time as a plastic liner inside a drum. A continuous liner is used which is drawn down for each new drum.

The red line points to where the liner is tied off twice before cutting it off. In this way the bottom tie seals the product within the drum whilst the top tie from the base of the next bag and prevents leakage from the dispensing unit above.

Again the facility is augmented by the use of LEV at the rear of the drum.



(Source: GSK – reproduced with permission)

**Figure 7.20**

Figure 7.20 shows a modified extraction hood over the top of a drum of solvent. This illustrates the principle of combining containment with Local Exhaust Ventilation and how this improves the performance of both.

## **8. PERSONAL PROTECTIVE EQUIPMENT**

### **8.1 GENERAL**

#### **8.1.1 Introduction**

In the management of occupational health and safety hazards and in particular in the control of hazardous substances there are three broad approaches that can be employed individually or in combination, as covered earlier. They can be described as:

- Engineering, such as ventilation
- Administrative, such as signs, procedures or substitution, and the last resort
- Personal protective equipment (PPE)

Making the “right choice” is difficult for those employees or supervisors lacking adequate knowledge and experience and this is particularly true for the PPE used for the control of hazardous substances. All too often this results in the wrong PPE being specified, with little or no training in its use and limitations being provided to users - yet the user believes the PPE is providing absolute protection.

Recommendations for the selection and use of PPE and the performance criteria required for the particular PPE is typically provided by International and National Standards.

It must be noted that there is currently no universal global harmonisation in respect to the standards for PPE. While some of the International Organisation Standardisation (ISO) Standards have been adopted by various National Standard setting organisations in different countries there are certainly still differences between some of the PPE standards from different countries. This is particularly in regard to those for respiratory protection.

### **8.1.2 Types of PPE**

PPE items are designed to protect the human body from interaction with chemicals and/or contact with energy hazards. There are many types of PPE and include types for:

- Head Protection
- Eye and Face Protection
- Hearing Protection
- Respiratory Protection
- Hand Protection
- Body Protection
- Foot Protection
- Protection Against Falling

### **8.1.3 PPE Programmes**

Where PPE is required to be worn a PPE programme or a set of routine procedures should be established by management and an individual assigned to manage the programme. The person ideally should have a technical and professional background enabling the person to make sound decisions based on evaluation and understanding of the workplace hazards. Preferably the person should be a safety professional, occupational hygienist or a physician. In a small company it may be the owner, foreperson or other supervisory personnel.

The person should develop a programme based on the following:

- The basis for the selection of the particular type of PPE
- Medical screening where required (eg: for respiratory, hearing or eyewear) for each employee assigned to wear the PPE
- An employee training programme in which the person can become familiar with the PPE and includes its proper use, the nature of the hazard and the need for protection



- The wearing of PPE does not make the wearer invincible. All PPE has some limiting factor inherent to its design and use. The limitations must be known and understood by the wearer
- Assigning PPE or clothing to employees for their exclusive use where practicable. This would not usually apply to equipment for emergency use
- Proper fitting of the PPE
- Regular cleaning and disinfection of the equipment or clothing
- Proper storage of the equipment or clothing eg: lockers adjacent to the work area
- Provision for periodic inspection and maintenance of the equipment and replacement where required
- A periodic evaluation by the administrator of the programme to assure its continuing functioning and effectiveness

For the purpose of this manual we will only consider in detail the following types of PPE:

- Respirator Protective Equipment
- Chemical Protective Clothing
- Gloves, and
- Eye and Face Protection

## **8.2 RESPIRATORY PROTECTIVE EQUIPMENT**

### **8.2.1 Introduction**

Respiratory protective equipment (respirators) is designed to provide protection against one or more of the following hazards:

- Deficiencies in oxygen
- Contaminants in particulate form
- Contaminants in gaseous or vapour form

It must be noted that where respirators are used for protection against particulates and gases and vapours they may not necessarily provide protection against deficiencies in oxygen.

Respirators help protect against certain airborne contaminants by reducing airborne concentrations in the breathing zone to below the exposure standard. Misuse of respirators may result in overexposure to the contaminant and cause sickness or death. For this reason, proper respirator selection, training, use and maintenance are mandatory in order for the wearer to be properly protected.

### **8.2.2 General Use Limitations**

- Air purifying respirators do not supply oxygen
- Do not use when concentrations of contaminants are immediately dangerous to life or health (IDLH), when concentrations are unknown, or in atmospheres containing less than 19.5% oxygen, unless using a self contained breathing apparatus (SCBA) or combination airline/SCBA
- Do not abuse or misuse the respirator
- Do not use tight fitting respirators or loose fitting facepieces with beards or other facial hair conditions that prevent direct contact between the face and the sealing edge of the respirator
- Do not use when concentrations exceed maximum use concentrations established by regulatory authorities

Note: IDLH is a term originally introduced by NIOSH in the USA to assist in the selection of respiratory protective devices. NIOSH defines an IDLH condition as “one that poses a threat of exposure to airborne contaminants when that exposure is likely to cause death or immediate or delayed permanent adverse health effects or prevent escape from such an environment” (NIOSH 2004)

### **8.2.3 Types of Respirators**

There are two main types of respirators:

- Air Purifying Respirators
- Air Supplied Respirators

## a) Air Purifying Respirators

There are two main types of air purifying respirators:

- Particulate respirators that filter out mechanically or thermally generated particles, or
- Gas and vapour respirators which filter out certain gases and vapours

There are also combination filters (particulate and gas and vapour) where both hazards are present.

The mode of air delivered to the wearer may be either one or a combination of two types:

- **Non-powered Respirator**

Contaminated air is drawn through the filter or filters by the wearer. The respirator may consist of a half facepiece with one or more replaceable filters, a filtering (or disposable style) facepiece, a full facepiece or head covering with one or more replaceable filters, or a mouthpiece and nose clip with an integral filter.



*Figure 8.1 – Filtering Facepiece or Disposable Respirator*



*Figure 8.2 – Half Face Respirator*



*Figure 8.3 – Full Face Respirator*

(Source: 3M Australia Pty Limited - reproduced with permission)

- **Powered Respirator**

Contaminated air is drawn through the filter or filters by means of a fan and delivered to the space enclosed by the head covering generally under positive pressure.

The respirator may be a half facepiece, full facepiece or head covering with one or more replaceable filters and an electrically (battery) operated fan or blower unit. Such respirators are often known as Powered Air Purifying Respirators (PAPRs).



(Source: 3M Australia Pty Limited – reproduced with permission)

**Figure 8.4 - Powered Air Purifying Respirator**

When considering filters for air purifying respirators there are a number of different types.

- **Particulate Filters**

Currently there are different terminologies used internationally to describe the filtering efficiencies or Classes of particulate filters and different test procedures are also used to classify these filter classes.

A very brief description of the main classification types is provided below. For further and more detailed information refer to the appropriate International or National Respirator Standards for the selection and use of respirators and for the relevant performance testing requirements in the list of References.

### AS/NZS Standards

Classes P1, P2 & P3 Filtering efficiencies determined by testing against a Standard test aerosol of sodium chloride.

Different classes are intended for use against mechanically generated (P1), thermally generated (P2) or highly toxic materials (P3).

### EN/UK/SA Standards

Classes P1, P2 & P3 Filtering efficiencies and filter degradation by oil is determined by testing against a Standard test aerosols of sodium chloride and paraffin oil.

### USA Standards

Classes 95, 99 & 100 for N, P & R type filters Filtering efficiencies and filter performance determined by testing against Standard test aerosols. Filters are classified as **Not** resistant to oil, **Resistant** to oil & **oil Proof**

**Table 8.1 – Comparison of Particulate Filter Classifications**

AS/NZS 1715	EN 529 / SA	NIOSH
P1	P1	
P2	P2	95 (N,P,R) 99 (N,P,R)
P3	P3	100 (N,P,R)

- **Substance Specific Respirators**

In some countries their regulations require a substance specific Class of respirator be worn for material such as asbestos, lead and hexavalent chrome.

- **Gas and Vapour Filters (Cartridges)**

The gas and vapour filter or sometimes referred to as a gas and vapour cartridge or gas and vapour canister removes certain gases from the inhaled air. The filter has a limited life which varies with the amount of sorbent (often activated or treated charcoal) and the conditions under which it is used. The service life of the filter is affected by such factors as the type, quality and quantity of the sorbent, the concentration of the contaminant in the air, the humidity and breathing rate of the person or volume of drawn through the filter by a PAPR. Manufactures are often able to provide information to users on the expected service life of their filters.

The main types of gas and vapour filters used in Australia/New Zealand and European Countries can include:

Type A	For use against certain organic gases and vapours as specified by the manufacturer.
Type B	For use against certain inorganic gases and vapours as specified by the manufacturer (but not for carbon monoxide).
Type E	For use against sulphur dioxide and other inorganic gases and acid gases as specified by the manufacturer (but not for carbon monoxide).
Type G	For use against low vapour pressure chemicals (vapour pressure less than 1.3 Pa (0.01 mmHg) at 25°C as specified by the manufacturer.
Type K	For use against ammonia and organic ammonia derivatives as specified by the manufacturer.
Type AX	For use against low boiling point organic compounds (less than 65°C) as specified by the manufacturer.
Type NO	For use against oxides of nitrogen.

Type Hg	For use against metallic mercury.
Type MB	For use against methyl bromide.
Specific	For use against one or more specific chemicals not falling into chemical type of any of the above type descriptions.

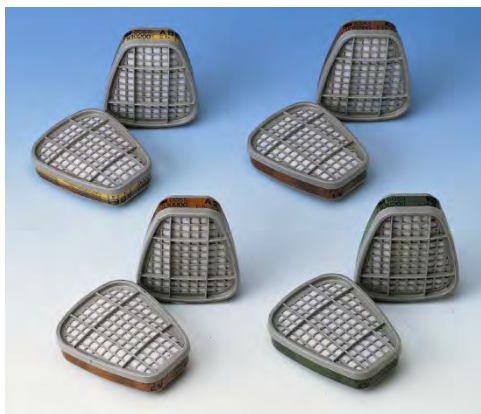

(Source: 3M Australia Pty Limited – reproduced with permission)

**Figure 8.5 - Gas and Vapour Filters**

These filters have a colour coded label that is intended to assist the user in the quick identification of the filter type of the filter.

*NB: There is no universal colour code system and there are differences in the colours used in the Europe/Australia and the colours used for example in the USA.*

*NB: Specialised gas and vapour filters used for First Response against terrorist or chemical warfare type agents are considered to be beyond the scope of this course and are therefore not covered here.*

- **Gas Filter Classification**

The class designation relates to the amount or capacity of the gas or vapours which can be collected by the gas and vapour filter. It is not an indication of the efficiency of the filter.

The gas and vapour filter may be available in four classes of increasing capacity ie the higher the class number the longer the filter will last under standardised conditions.

The Classes are:

Class AUS Low absorption capacity filters with a shorter life than Class 1

Class 1 Low to medium absorption capacity filters

Class 2 Medium absorption capacity filters

Class 3 High absorption capacity filters

Generally, but not necessarily always, a higher class filter will have a greater mass and filter volume as well as a greater absorptive capacity than a corresponding lower class of filter. The mass and bulk will determine the choice of facepiece style and harness configuration as required by Respirator Standards.

Limits are placed on the mass that can be connected to a half facepiece, a full facepiece and when the filter needs to be body mounted. The mass limitations are intended to minimise respirator instability and discomfort when worn and apply to both non powered and powered air purifying respirators.

- **Combination Particulate and Gas and Vapour Filters**

When an airborne particulate hazard together with a gas and vapour hazard are present a combination particulate and gas and vapour filter must be used. Examples include the spray paint industry where liquid droplets and organic vapours are present, or in the aluminium smelting industry where fluorides can be present as particulate sodium fluoride and gaseous hydrogen fluoride.

The combinations can be either:

- Filter combination comprising of a gas and vapour filter with a separate particulate filter attached on the inlet side.





(Source: 3M Australia Pty Limited – reproduced with permission)

**Figure 8.6 – Particulate Filter, Filter Retainer and Gas and Vapour Filter**

- Integral combined filter which incorporates both the gas and vapour filter and the particulate filter into a single unit.

An additional external or pre-filter filter may be added to both types to remove large sized particles and thus extend the life of the main particulate filter.

Where the particulate filter and gas and vapour filter are separate components they must be placed so the inhaled air passes through the particulate filter first. In some cases, combination filters are specified for use in circumstances where they are not really required. This can result in greater discomfort to the users, as there will be greater resistance to breathing, than single filters and this will add to the negative influences experienced by the user – making incorrect use more likely.

- **Substance Specific Respirators**

In some countries their regulations require a substance specific respirator be worn for materials such as vinyl chloride and benzene for example.

**b) Supplied Air Respirators**

Supplied air respirators deliver breathing quality air to the wearer from an independent source. There are three main types of supplied air respirators:

- **Airhose Respirators**

The air supplied to this type is not pressurised ie: it is at or near atmospheric pressure.

Typically the air is provided by a wide bore “hose” for natural breathing or the airhose can be connected to a low pressure blower. The intake of the airhose needs to be firmly secured in a contaminant free area. The breathing resistance of the air hose is limits the length of hose length, but this can be lengthened by use of hand operated pump or bellows or a low pressure blower.

- **Airline Respirators**

The air supplied is pressurised ie it is greater than atmospheric pressure. Typically the air is delivered from an air compressor or a bank of large compressed air gas cylinders via a relatively narrow bore “airline”. The air must be of acceptable breathing air quality.

The air supplied to airline respirators may be delivered in a number of ways:

- Continuous air flow typically to a loose fitting head covering or face piece which is above atmospheric pressure or at positive pressure with the “excess air” escaping from the head top thus preventing the ingress of the contaminant

- Negative pressure demand where the pressure inside the facepiece is less than that of the immediate environment during inhalation, causing the demand valve to open, supplying air to the wearer. Tight fitting facepieces are worn with this type of system
- Positive pressure demand where the pressure inside the close fitting facepiece remains greater than the immediate environment. The demand valve opens automatically to supply air to the wearer when the positive pressure inside the facepieces decreases to a preset minimum



(Source: Dräger Safety Pacific Pty Ltd – reproduced with permission)

**Figure 8.7 – Airline Respirator**

- **Self Contained Breathing Apparatus (SCBA)**

The air supplied is pressurised and uses cylinders of compressed air strapped to the user's body. This type of system allows the wearer to move freely about without the restriction of an airhose or airline.



(Source: Dräger Safety Pacific Pty Ltd – reproduced with permission)

### **Figure 8.8 – Self Contained Breathing Apparatus**

The air quality for supplied air respirators of necessity needs to be of acceptable breathing quality. The intakes to any air compressor system need to be located in contaminant free area and it is generally recommended that the supplied air shall:

- Have no objectionable odour
- Contain not less than 19.5% and not more than 22% by volume of oxygen
- Contain less than 10 ppm carbon monoxide
- Contain less than 800 ppm of carbon dioxide
- Contain less than 1 mg/m<sup>3</sup> oil
- Contain water/moisture content less than 50 mg/m<sup>3</sup> (to prevent ice formation in pressure let down valve)

Advice should be sought from National Respiratory Protection Standards to confirm local requirements for breathing air quality as these may be different to the above recommendations.

## 8.2.4 Selection and Use of Respirators

The selection of a suitable respirator depends on the nature, physical form, toxicity and concentration of the contaminants present in the workplace, the tasks to be undertaken as well as factors relating to the wearer.

### a) Assessment of Exposure

In order to select a respirator with the appropriate filtering capability an assessment of the exposure must be carried out. The measured concentration is then compared to the appropriate occupational exposure standard to enable the correct respirator and filter to be selected.

### b) Protection Factors and Exposure Standards

The “protection factor” is a measure of the reduction of exposure that can be expected to be provided by a particular respirator type. The protection factor is defined as the ratio between the concentration outside the respirator to the concentration inside the respirator ie breathed by the wearer. The “protection factor” and can also be expressed by the following equations:

$$\textit{Protection Factor} = \frac{\textit{Ambient Airborne Concentration}}{\textit{Concentration Inhaled Inside the Respirator}}$$

$$\textit{Required Minimum Protection Factor} = \frac{\textit{Ambient Airborne Concentration}}{\textit{Acceptable Exposure Level or Standard}}$$

The ‘required minimum protection factor’ for any given situation is that factor necessary to reduce the exposure of the wearer to below an accepted level or exposure standard.

Other terms that are used internationally in relation to this concept include assigned protection factors, nominal protection factors, and required minimum protection factor and are all attempts to indicate levels of protection likely to be provided by a correctly selected and properly worn respirator.

Tables of 'required minimum protection factors' are provided in the relevant standards to assist in the selection of particular levels of respiratory protection devices.

An example will assist in the understanding of this concept

If the ambient concentration was say  $0.5 \text{ mg/m}^3$  for xyz dust and the exposure standards for xyz dust were  $0.1 \text{ mg/m}^3$ .

The required minimum protection factor =  $0.5/0.1 = 5$

In AS/NZS 1715: 2009 the "required minimum protection factor" for P1, P2 or P3 filter half facepiece respirators with replaceable filter or disposable style are assigned the same "factor" of 10.

We could therefore recommend that a P1 respirator would provide an adequate level of protection if worn correctly in these circumstances.

If however the concentration of xyz dust was  $1.5 \text{ mg/m}^3$

The required minimum protection factor =  $1.5/0.1 = 15$

A higher level of protection is required

To obtain a higher level of protection against particulates it is necessary to use a full facepiece or go to a Powered air purifying respirator which affords a higher "factor" of up to 50.

For higher "factors" of up to 100 P3 filters in a full facepieces or full facepiece airline respirators (negative pressure demand) are required to be used.

For "factors" above 100 suitable respirators are typically airline respirators with continuous flow air supplies.

The same concept can be applied to the similar terminologies used in the British, European, South African, USA and other National Standards as required.



This is a term used in respiratory protection to describe acute respiratory exposure that specifically poses an immediate threat of loss of life, immediate or delayed irreversible adverse effects on health, or acute eye exposure that would prevent escape from a hazardous atmosphere.

- Does the contaminant have irritant eye properties (if eye and or face protection is required a full facepiece respirator may be necessary)?

**d) Task Related Selection Factors**

- The length of time the respirator will be worn
- Whether the respirator will be worn regularly
- The mobility required of the wearer
- The nature of the workplace, whether confined or restricted, thermal conditions
- The need for communication
- Other PPE which must be worn eg: safety helmet, ear muffs, safety glasses

**e) Operated Related Selection Factors**

- The fitness of the wearer to withstand the extra physiological/ psychological strain of working while wearing a respirator
- The ability of the person to accept the constriction of wearing the respirator
- Facial hair
- Whether a person wears glasses which may affect the facial seal of the respirator
- Whether the person has facial features such as scars or acne or other aspects that may affect the facial seal of the respirator



- Gender considerations as women often have smaller sized faces and hence may need a smaller sized respirator
- Ethnic considerations as the shape of facial features varies and must be considered

### 8.2.5 Training

The purpose of training is to enable the wearer to understand:

- Why the respirator is necessary and why the other hierarchy of control measures are not immediately feasible
- How the respirator provides protection
- Limitations of the respirator, including the service life of filters
- How and why the respirator was selected
- Proper fitting of the respirator
- The importance of wear time
- Maintenance, cleaning and storage requirements

### 8.2.6 Wear Time

Respirator performance is dependent on four primary characteristics. Three of these are:

- Filter efficiency
- Proper Fit
- Proper maintenance

However, the fourth characteristic of **Wear Time** is often overlooked or ignored. The effective protection given by RPE is determined to a major extent by wear time:

- Respiratory protective equipment can be the best designed, most effective filtering device on the market, but if it is not worn when it should be the drop in protection for the user in some cases can be dramatic

- This chart plots levels of protection of respirators against the effect of not wearing them during an 8 hour work shift
- The first 10 minutes of non wear time tends to affect the higher protective devices the most
- Even a product with a protection factor of 50 will drop down to about 30 if not worn for 10 minutes
- Therefore the importance of wear time and good training and education of the user cannot be stressed enough. Often harmful dusts can remain in the air for 20 minutes or more after work has finished

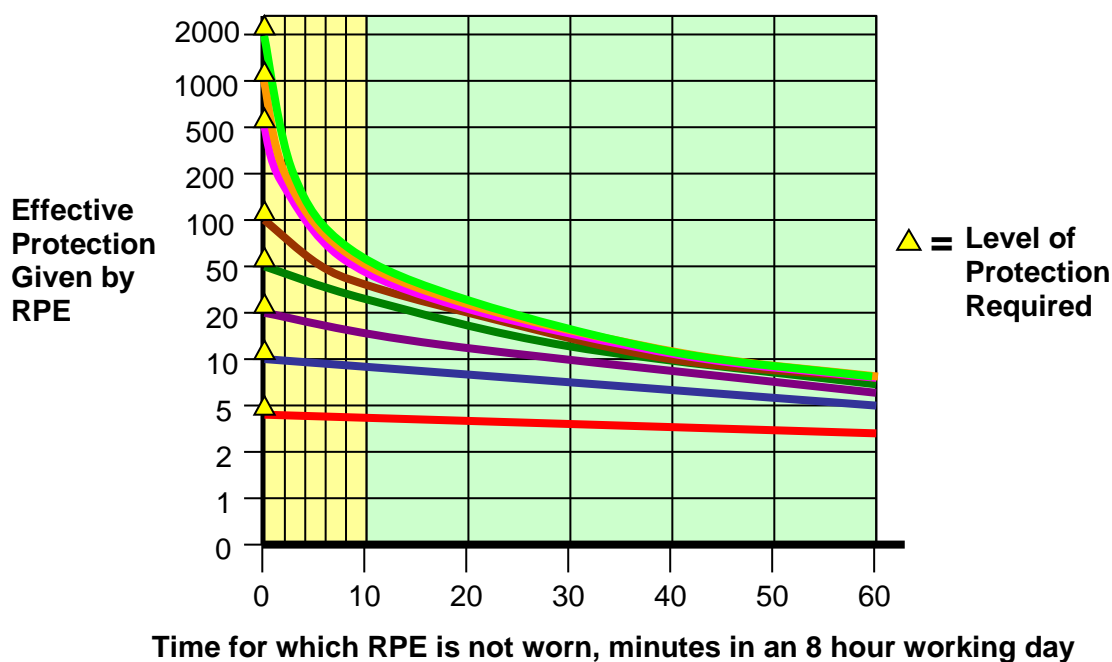

(Source: 3M Australia Pty Limited – reproduced with permission)

**Figure 8.10 – Respirator Wear Time Vs Effective Protection**

### 8.2.7 Respirator Fit Testing

Humans come in many shapes and sizes as do respirators. The ability of a respirator to form a satisfactory seal between the wearer and the contaminated environment may be significantly affected by these variables.

A fit test is used to assess whether a specific type, model and size of respirator can adequately fit a specific individual.

Another equally important reason for fit testing is to ensure that an individual knows how to don (put on) and wear the respirator. The proper size respirator will provide little protection if not worn correctly.

Respirator fit testing is an integral part of a respirator protection programme. Respirator fit tests should be repeated annually.

There are two types of Fit Test:

- **Qualitative Fit Testing**

Qualitative fit testing is a pass/fail test relying on the subject's voluntary or involuntary response to a challenge test agent ie: taste, smell or irritation. Typically tests are carried out in some form of "enclosure" such as hood or suspended tent enclosure. Typical test agents are:

- Isoamyl acetate (banana like odour) and is only suitable for respirators using organic vapour filters
- Saccharin mist spray is suitable for any respirator incorporating a particulate filter. It relies on the subject's ability to detect saccharin aerosol by taste. Individuals vary in their taste threshold so a screening procedure is used to establish suitability
- Bitrex mist spray is also suitable for any respirator incorporating a particulate filter. It relies on the subject's reaction to the bitter taste of the test agent
- Irritant smoke test using either stannic chloride or titanium tetrachloride. The irritant smoke test should be used with caution because the aerosol is highly irritating to the eyes, skin and mucous membrane. For this reason the agent is not routinely used



(Source: 3M Australia Pty Limited – reproduced with permission)

**Figure 8.11 – Qualitative Fit Testing with Saccharin or Bitrex**

- **Quantitative Fit Testing**

Quantitative Fit Testing involves placing the wearer in an atmosphere containing an easily detectable, relatively low toxicity gas, vapour or aerosol. The atmosphere inside the respirator is sampled through a probe in the respirator. The leakage is measured as a concentration inside the respirator as a percentage of the outside concentration.

The most commonly available commercial devices use the following types of test agents:

- Sodium chloride
- Oil mist
- Particle counters



(Source: Kenelec Scientific Pty Ltd – reproduced with permission)

**Figure 8.12 – TSI Fit Test Particle Counter**

- **Fit Checking**

Fit checking involves the wearer covering the inhalation ports of a half or full facepiece replaceable filter style respirator and inhaling gently. The respirator should be drawn into or collapse slightly onto the face (ie: it is under a slight vacuum) and remain collapsed thus indicating there is no inward leakage and hence a good respirator fit has been achieved. Alternatively with the exhalation port covered, if you exhale gently the facepiece should bulge slightly and remain bulged while exhaling.

If you cannot get an effective seal adjust the position of the respirator on the face and readjust the straps and repeat. If you still cannot get a seal do not enter the contaminated area.



(Source: 3M Australia Pty Limited – reproduced with permission)

**Figure 8.13 – Fit Testing**

For disposable or filtering facepiece style fit checking can also be performed. Cup both hands over the respirator and inhale sharply.

If air flows around the edge of the respirator readjust the nose piece and straps and repeat. If you still cannot get an effective seal do not enter the contaminated area.

### **8.2.8 Cleaning Maintenance and Storage**

It is essential that cleaning, maintenance and storage procedures for respirators are in place to ensure the effective operation and ready availability of respirators. The manufactures provide advice in this regard and their instructions must be followed. People who undertake the cleaning and or maintenance programmes, including users who clean their own respirators, must be properly trained.

- **Cleaning**

The frequency of cleaning will generally depend on the frequency of use and the amount of soiling of the respirator. Where respirators are used routinely daily cleaning is often required.

Respirators may be washed with a mild detergent using warm water using a soft brush. Care must be taken to avoid rough handling, especially if machine washing is employed. Following cleaning, the respirator should be disinfected, thoroughly rinsed with clean water and allowed to dry.

The manufacturer's instructions on suitable detergents, disinfectants, cleaning procedures (especially where machine washing is undertaken) must be sought and strictly followed.

- **Maintenance**

Respirators should be checked before and after use and a thorough check undertaken during cleaning. People performing the maintenance must be trained.

Check disposable style respirators for physical damage, missing straps or damage to and elasticity of straps and for any deterioration of the nose piece sealing. These respirators must be discarded if found to be faulty.

For reusable style respirators check each facepiece for damage, tears, cracks, distortion, dirt and residues, damaged or missing valves and valve seats, worn or missing gaskets, worn threads, missing straps, or deterioration and loss of elasticity of straps.

Follow the manufacturer's instructions, use only approved replacement parts and do not use parts from another product type or manufacturer

Particulate filters should be replaced when they become damaged or breathing resistance is such that they are difficult to breathe through.

Gas and vapour filters have a finite life and should be replaced at the end of their expected service life. The filter manufacturers can provide this information.

Regardless of the number of periods of use the majority of national standards recommend all types of gas and vapour filters should be discarded six months after opening.

For PAPRs, the head top, air hose, flow rates, pump and batteries must also be checked in accordance with the manufacturer's recommendations.

SCBAs are such a specialised piece of equipment typically used in IDLH and potentially life threatening situations that only trained specialists should service this type of respiratory protective equipment.

- **Storage**

Respirators should be stored as close as practicable to the workplace, be kept clean and dry and away from sources of contamination, heat and exposure to direct sunlight. Storage in a resealable plastic bag may be beneficial.

Stored respirators, particularly those used infrequently eg: those stored for emergency use, must be expected frequently to ensure they are clean, free from dust, moisture and mould and are ready for use if required.

The service life for gas and vapour filters can be affected by storage and exposure to contaminants in the air.

### **8.2.9 Medical Evaluation**

Wearing a respirator may place additional strain on the respiratory and cardiac systems of the wearer. Workers who are required to routinely wear a respirator must be medically assessed to ensure they are capable of withstanding this additional strain. Workers with a history of asthma, emphysema, who suffer from chronic lung disease or those with circulatory or heart disease may be at risk from wearing a respirator.

It is also necessary to consider psychological factors as some workers may have a feeling of isolation or claustrophobia which limits their ability to work while wearing a respirator.

Wherever respiratory protection is used for the protection of workers appropriate health surveillance measures must be in place to assess the effectiveness of exposure control.

### **8.2.10 Record Keeping**

Records shall be kept of:

- The process to select the appropriate respirator
- The training provided to the workers
- Maintenance and inspection programmes for respirators
- Fit test conducted and results of those tests
- Medical assessment and surveillance (these records must meet medical confidentiality guidelines)



### **8.2.11 Evaluation**

A periodic evaluation of the respiratory protection programme should be undertaken to ensure that:

- The reasons for implementing the programme remain valid, including a review of the concentration of the workplace contaminants
- The respirators are being worn in the workplace
- The respirators are being worn correctly in the workplace
- The maintenance procedures are functioning correctly
- The programme continues to meet its intended goals

## **8.3 CHEMICAL PROTECTIVE CLOTHING**

### **8.3.1 Introduction**

The purpose of chemical protective clothing (CPC) and equipment is to protect the wearer from the chemical, physical or biological hazards that may be encountered in the workplace. CPC can be obtained as one-piece fully encapsulating gas tight (“moon”) suits with attached gloves and boots or as multiple components (eg: pants, jackets, hoods etc).

The hazards may be particularly obvious and apparent whilst other hazards may be not be and have no warning properties. There is no one single combination of protective equipment and clothing that is capable of providing protection against all hazards and the selection of such equipment must be such that it provides an adequate level of protection for the particular situation.

There are many tasks, situations and applications where CPC is required to be worn and include:

- Emergency hazardous material response
- Environmental/contaminated site clean up
- Nuclear applications

- Pharmaceutical production
- Chemical waste management
- Spray painting
- Petrochemical manufacturing
- Chemical handling and transport
- Waste treatment
- Biological hazards and medical applications
- Asbestos removal
- Pesticide application
- Food processing

Different types of protective clothing are required for the different applications and factors to be considered in the selection of appropriate protective clothing are:

- Chemical substances
- Exposure type
- Chemical protective type
- Garment design
- Sewing or construction methods
- Sizing
- Visibility

### **8.3.2 Types of Chemical Protective Clothing**

There is currently no global harmonisation in regard to chemical protective clothing. Recommendations for the selection and use of CPC and the performance criteria required for the particular CPC is typically provided by International and/or National Standard Setting Organisations or Agencies.

**a) ISO/EN Classification**

All chemical protective clothing shall be tested for integrity and material chemical resistance and classified by type based on its minimum integrity and material chemical resistance (ISO 16602:2007 and EN 374:2003).

A brief summary of the Types of CPC is provided below.

Type 1 "Gas-tight" chemical protective suit.

Covers the whole body, including hands, feet and head.

Type 1a air supply worn inside suit

Type 1b air supply worn outside suit

Type 1c external source of breathable air providing positive pressure inside suit

All Type 1 chemical protective suits shall be evaluated for leak tightness and shall pass a pressure test. All Type 1 chemical protective suits shall have materials that demonstrate chemical permeation resistance.

Type 2 "Non gas-tight" chemical protective suit.

A "non gas-tight" chemical protective suit with breathable air providing positive pressure inside the suit from an independent source.

eg: An airline suit which is not gas tight.

Type 2 chemical protective suits shall be evaluated for inward leakage and shall pass the inward leakage test, and shall have materials that demonstrate chemical permeation resistance.

Type 3 “Liquid-tight” chemical protective clothing.

Full body chemical protective clothing with liquid-tight connections between different parts of the clothing, and to gloves and boots to protect the wearer against liquid chemicals.

eg: One-piece coverall or two-piece suit, with or without hood or visor with or without boot-socks.

Type 3 clothing shall be evaluated for resistance to penetration by liquids and shall pass the continuous liquid jet test and shall have materials that demonstrate chemical permeation resistance.

Type 4 “Spray-tight” chemical protective clothing.

Full body chemical protective clothing with spray-tight connections between different parts of the clothing and to gloves and boots to protect the wearer against liquid chemicals.

eg: One-piece coverall or two-piece suit, with or without hood or visor with or without boot-socks.

Type 4 chemical protective clothing shall be evaluated for resistance to penetration by liquids and shall pass the liquid spray test and shall have materials that demonstrate liquid penetration resistance under pressure or chemical permeation resistance.

Type 5 CPC against airborne solid particles.

Full body chemical protective clothing, with or without gloves and boots to protect the wearer against airborne solid chemicals.

eg: One-piece coverall or two-piece suit, with or without hood or visor with or without boot-socks.

Type 6 Chemical Protective Clothing with “limited protective performance against liquid chemicals.”

Full body chemical protective clothing with limited spray-tight connections between different parts of the clothing. and to gloves and boots to provide limited protection of the wearer to liquid chemicals.

eg: One-piece coverall or two-piece suit, with or without hood or visor with or without boot-socks.

Partial body (“PB”) chemical protective clothing.

Chemical protective clothing that does not provide full body coverage.

eg: Aprons, boot/shoe covers, gowns, hoods, jackets, lab coats etc.

## b) US OSHA / EPA Guidelines

In the USA the approach could be considered as a “clothing and equipment ensemble” approach of items which are easily integrated to provide an adequate level of protection.

The components that may form the ensemble include:

- Protective clothing (suit, coveralls, hoods, gloves, boots)
- Respiratory protective equipment (SCBA, airline systems, air purifying respirators)
- Cooling systems (ice or phase change vests, air or water circulation systems)
- Communication devices
- Head protection
- Eye and face protection

- Hearing protection
- Inner garments
- Outer garments

**c) EPA Levels of Protection**

These components are included in the widely used EPA Levels of Protection.

- Level A (Vapour or Gas Protection)
- Level B (Liquid Splash Protection)
- Level C (Particle or Liquid Splash Protection)
- Level D (No Hazard Protection)

Following is a brief summary of the US EPA's (Environmental Protection Agency) "Levels of Protection (LOP)" as applicable to those individuals involved in handling hazardous materials. LOP's are based on the type of respiratory protection required to ensure the safety of the user under the specified conditions of use.

Along with respiratory protection, EPA's LOP's recommend the protective ensemble that the user should wear to ensure adequate protection. Also LOP's describe what this recommended protective ensemble should consist of and look like, but not necessarily how the various components should perform. NFPA (National Fire Protection Agency) standards specify actual performance criteria for the protective clothing that might be recommended under a LOP.

**LEVEL A (Vapour or Gas Protection)**

- The highest available level of respiratory protection
- Fully encapsulated chemical suit with breathing apparatus
- Chemical hazard will typically have a high vapour pressure and toxicity through skin absorption or carcinogenic

- Work conditions that have a high potential (probability) for exposure to very high concentrations of chemical splash, immersion, or exposure to chemical vapours
- Situations that may involve unknown chemicals or chemical combinations

The employer shall verify that the required workplace hazard assessment has been performed through a written certification that identifies the workplace evaluated; the person certifying that the evaluation has been performed; the date(s) of the hazard assessment; and, which identifies the document as a certification of hazard assessment.

#### **EPA Level A - Personal Protective Equipment Guidelines**

- Respirator (supplied air)
  - Positive Pressure/Pressure Demand
  - SCBA (Self Contained Breathing Apparatus)
  - Supplied Air (with emergency egress unit)
- Fully encapsulating chemical resistant suit
- Gloves, chemical resistant
- Boots, chemical resistant, steel toe and shank

#### **LEVEL B (Liquid Splash Protection)**

- The same level of respiratory protection is required as in Level A. However, a lesser degree of skin protection is needed than for Level A
- Level B protection allows for certain areas of exposed skin on the wearer. In the past, Level B protective clothing would include either a one piece or two-piece ensemble with the SCBA worn outside the garment. Separate gloves and boots would be "taped" or "sealed" at the interfaces to minimize chemical penetration.

The trend now is to use encapsulating garments that are not "vapour tight" as Level B garments

- Chemicals that are known not to be vapours or gases that are toxic by skin absorption, or are carcinogenic
- Exposure situations will typically be at lower chemical concentrations (below established exposure limits)

### **EPA Level B - Personal Protective Equipment Guidelines**

- Respirator (supplied air)
  - Positive Pressure / Pressure Demand
  - SCBA (may be external back pack)
  - Supplied air line
- Chemical resistant clothing. Coverall, splash suits, one or two piece
- Gloves, chemical resistant
- Boots (outer) chemical resistant, steel toe and shank

### **LEVEL C (Particle or Liquid Splash Protection)**

- The same level of skin protection as Level B, but a lower level of respiratory protection is needed (ie: air purifying respirators)
- One or two piece splash suits are worn with a cartridge respirator
- Chemicals are not hazardous via skin absorption and are typically well below established exposure limits

### **EPA Level C - Personal Protective Equipment Guidelines**

- Air purifying respirator (NIOSH approved)
- Chemical resistant clothing, splash suit, one or two piece
- Gloves, outer, chemical resistant
- Boots, outer, chemical resistant, steel toe and shank



**LEVEL D (No Hazard Protection)**

- No respiratory protection and very little skin protection is needed
- Coveralls and general safety gear (ie: shoes, gloves, eye, head wear) are worn
- The work environment has no possibility for contact with hazardous chemicals. (The workers do not expect to come in contact with chemicals)

**Note:** *PEL's, REL's, etc. all are Recommended or Permissible Exposure Limits and are set by organisations such as NIOSH and OSHA.*

**EPA Level D - Personal Protective Equipment Guidelines**

- Coveralls
- Boots/shoes, leather or chemical resistant
- Miscellaneous (ie: head, eyewear, hearing protection, etc.)

**8.3.3 Chemical Protective Clothing Materials****a) Types of Materials**

There are many materials used to manufacture chemical protective suits and protective clothing and in part have been summarised (Popendorf 2006) and include:

- Tyvek® - Spun bound olefin coated polyethylene. Because Tyvek is not a membrane it is breathable. It therefore provides no protection against vapours, is only weakly resistant to liquids, but is protective against particulates (powders and fibres)
- Nomex® - A woven aromatic polyamide that is resistant to many chemicals (but provides no particular chemical protection by itself) and is a good choice for flame resistance (including electric arc and flash fires), thermal protection, comfort and durability

- Saranex® - A laminated polyvinylidene chloride membrane (basically Saran®) bonded between polyolefins like polyethylene and/or ethylene-vinyl acetate. It can be used to coat a fabric substrate to form a protective cloth
- FEP – A fluorinated ethylene-propylene copolymer (related to Teflon®). FEP can also be applied onto a woven substrate (such as Tyvek) to form either a liquid resistant film or a membrane
- Gore-Tex® - Woven polytetrafluorethylene (PTFE, TFE or Teflon®) resists water permeation (and therefore can protect against aqueous mixtures) but is air and water vapour permeable which is good for cooling but not for protection against organic vapours
- ProShield® - A proprietary, multilayer fabric from DuPont® combines a microporous film on a spun bound polypropylene fabric to create a liquid waterproof barrier that allows water vapour to pass

Manufacturers, eg: Microgard®, also coat some of the above and similar spun and woven materials with a variety of chemically resistant membranes, coatings and laminates to provide protection against a wide range of chemicals.

## **b) Chemical Resistance of Materials**

Different materials provide different levels of resistance to the effects of hazardous chemicals caused by:

- Penetration - is the movement of chemicals through zippers, seams, or imperfections in a protective clothing material
- Degradation – involves physical changes in a material as a result of a chemical exposure, use or ambient conditions (eg: sunlight) and includes discolouration, swelling and the loss of physical strength or deterioration

- Permeation – is the process by which a chemical dissolves in or moves across a material on a molecular basis. In most cases there will be no visible evidence that permeation has occurred

There is a Standard (ASTM) list of 15 liquid and 6 gaseous chemicals which represent a cross section of different chemical classes and challenges for testing of protective materials. Manufactures typically have available test data on hundreds of other chemicals

The results of permeation tests are expressed in a number of ways:

- Permeation rate - is the rate at which the hazardous chemical permeates through the test fabric as is expressed as a mass per a unit of time eg:  $1.0 \mu\text{g}/\text{cm}^2/\text{minute}$
- Actual breakthrough time – the average time elapsed between initial contact of the chemical with the outside surface of the fabric and the detection of the chemical at the inside surface of the analytical device
- Normalised breakthrough time – the average time elapsed between initial contact of the chemical with the outside surface of the fabric and the time at which the chemical is detected at the inside surface of the fabric at the permeation rate specified by the appropriate standard

EN 374.3 specifies a normalised permeation rate of:

$1.0 \mu\text{g}/\text{cm}^2/\text{minute}$ .

ISO 6529:2001 allows the rate to be reported as the normalised permeation rate of  $1.0 \mu\text{g}/\text{cm}^2/\text{minute}$  or  $0.1 \mu\text{g}/\text{cm}^2/\text{minute}$ .

ASTM F739 specifies results to be recorded as breakthrough time (BT) at  $0.1 \mu\text{g}/\text{cm}^2/\text{minute}$ .

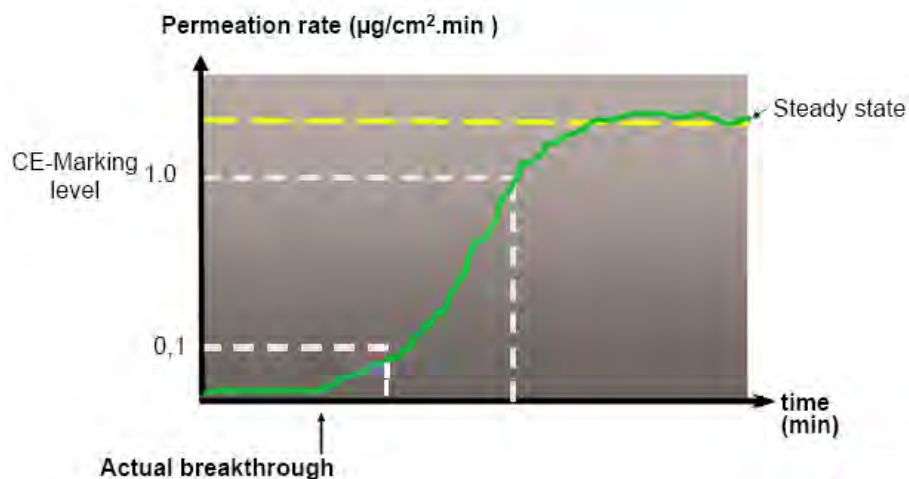

(Source: Microgard – reproduced with permission)

**Figure 8.14 – Actual Breakthrough Time**

Useful sources of information on the selection protective clothing for specific chemicals include:

- NIOSH Pocket Guide to Chemical Hazards which can be accessed at [www.cdc.gov/niosh/ncpc/ncpc1.html](http://www.cdc.gov/niosh/ncpc/ncpc1.html) accessed August 2008
- NIOSH Recommendations for Chemical Protective Clothing at [www.cdc.gov/niosh/ncpc/ncpc2html](http://www.cdc.gov/niosh/ncpc/ncpc2html) accessed August 2008

OR from the manufactures including:

- DuPont – SafeSPEC software tool at [www.personalprotection.dupont.com](http://www.personalprotection.dupont.com) accessed August 2008
- Microgard [www.microgard.com](http://www.microgard.com) accessed August 2008

### c) Seam Construction

While the chosen material itself may be the most appropriate for chemical the manufacture of clothing necessitates the use of seams, unlike the manufacture of gloves where they can be moulded.

Seams can be sealed or made without external perforations in a variety of ways by manufacturers:

- Serged or sewn seam (strong, but not sealed)
- Bound serged seam (better, but not sealed)
- Folded and taped serged seam
- Folded and double taped serged seam
- Heat sealed or welded seam

The more completely that a seam is sealed, the more protective and costly it is.

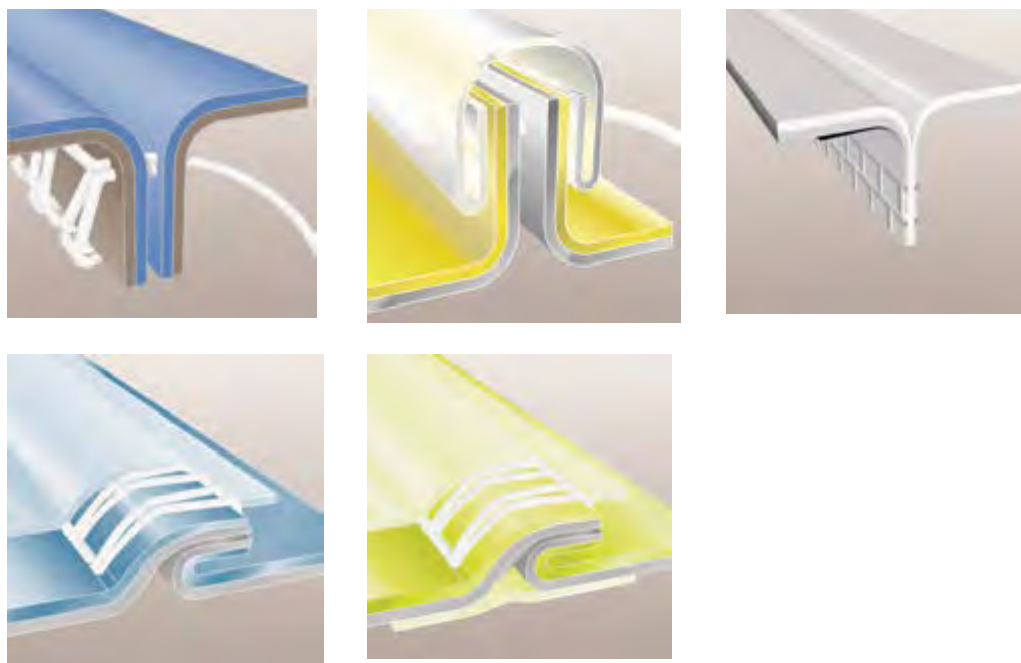

(Source: DuPont Personal Protection – reproduced with permission)

**Figure 8.15 – Seam Constructions**

#### d) Clothing Style & Size

Different jobs require different style or configurations of the protective clothing. Manufacturers offer a variety of styles and from hoods and vests, to aprons, coveralls up to fully encapsulating suits in a range of sizes.



(Source: DuPont Personal Protection – reproduced with permission)

**Figure 8.16 – Garment Styles**

#### 8.3.4 Standard CPC Test Procedures

Standard Test Methods are used to assess the performance of both the Physical Properties and Chemical Resistance Properties of CPC and are published by a number of International and National Standards setting organisations and include those from:

- ISO Standards
- EN Standards
- ASTM Standards
- NFPA Standards
- AS/NZS Standards

Chemical resistance of protective clothing material is determined by Specific Performance Tests for:

- Permeation resistance
- Resistance to penetration by liquid under pressure
- Particulate penetration resistance
- Liquid penetration resistance

- Liquid repellency

Whole chemical protective clothing item integrity is determined by Specific Performance Tests for:

- Leak tightness
- Inward leakage
- Liquid jet test
- Liquid spray test
- Particle aerosol inward leakage test
- Limited liquid spray test

### **8.3.5 Use of Chemical Protective Clothing**

A lot of the development and terminology used in relation to CPC has come from the emergency response and hazardous waste and hazardous material industries:

- Hot zone – the contaminated area where workers must wear the appropriate Type or Level of PPE
- Warm zone – where the equipment and personnel are decontaminated in transit from the hot to cold zone
- Cold zone – the clean area where no PPE is required

Different Types (1 to 6) or different Levels (A to D) of CPC as described earlier are intended for use across different “zones”.

Minimise the need for decontamination by:

- Minimise chemical contact in the hot zone
- Wear disposable outer garments
- Use remote handling techniques where possible (eg: drum grapples, tools etc)
- Avoid open pockets or folds that can serve to collect contaminants

- Teach procedures to minimise wearer contact within the hot zone and with contaminated clothing in the warm zone to prevent the spread of contamination
- Try to protect equipment taken into the hot zone (eg: place sampling equipment in a bag with openings for port and sensors, or cover tools with a strippable coating)

### **Develop a Decontamination Plan**

- Define the decontamination methods and equipment to be used.
  - Detergents – generally limited to removing only surface contamination or those that are water soluble or emulsifiable
  - Solvents – can remove more hydrophobic contaminants, but they generate large volumes of contaminated waste solvent and may have a detrimental effect on the CPC material
  - Low heat – approximately 50°C to drive off volatile organics, but may also have detrimental effect on the material or glues used to tape seams
  - Natural aeration – is a function of time, volatility and extent of permeation
- Have a series of decontamination stations.
  - Upon exiting the hot zone, the focus at Station 1 is gross decontamination of surface contamination, before moving to Station 2 or 3 for doffing etc
  - Contaminants that have permeated may have to be treated offsite
- Anticipate the effects of the following factors on the contamination of used CPC, PPE and other equipment taken into the hot zone and/or the necessary efficiency of decontamination.
  - The concentration of the contaminant(s) in the hot zone
  - The contact time with the contaminant(s)
  - The physical state of the contaminant(s)



- The temperature (which can affect the chemical's diffusion into the material)
- While it is difficult to quantify an acceptable level of decontamination the following methods may assist:
  - Visual inspection for gross residues or chemical degradation
  - Wipe samples
  - Destructive testing
- Disposal

Uncontaminated chemical protective clothing may be incinerated. Contaminated clothing should be handled as contaminated waste in accordance with local and national regulations.

OSHA provide detailed advice on Decontamination Procedures for Chemical Protective Clothing in their OSHA Technical Manual – accessed August 2008 at [http://www.osha.gov/dts/osta/otm/otm\\_viii/otm\\_viii\\_1.html](http://www.osha.gov/dts/osta/otm/otm_viii/otm_viii_1.html)

### **8.3.6 Inspection and Storage**

- Inspection should include the following:
  - Inspection of equipment when received
  - Inspection of equipment as it is selected for use
  - Inspection after use
  - Periodic inspection of stored equipment
- Storage

CPC must be stored properly to prevent damage or malfunction from exposure to dust, moisture, sunlight, damaging chemicals, extremes of temperature and impact. Recommended instructions provided by manufacturers should be followed.

Other general guidelines for storage of CPC include:

- Potentially contaminated clothing should be stored in an area separate from street clothing or unused protective clothing
- Potentially contaminated clothing should be stored in a well ventilated area with good air flow around each item
- Different types and materials of clothing and gloves should be stored separately to prevent the issue of the wrong item
- Protective clothing should be folded or hung in accordance with manufacturer instructions

### **8.3.7 CPC Limitations**

In addition to limitation discussed earlier with regard to material selection, garment design etc there may other potential limitations placed on the use of CPC in some situations:

- Heat Stress  
CPC can cause heat stress to the wearer due to the decrease in evaporative cooling of sweat while wearing impervious type clothing. This can be compounded by additional metabolic work simultaneously being carried by the wearer. The use of air cooled suits can assist in overcoming this concern
- The design of CPC can impair the vision, mobility and manual dexterity of the wearer
- Communication can also be compared when wearing respiratory or hearing protection while wearing CPC. Radio communication devices are available for use with CPC

### **8.3.8 Training**

Training and education for users of CPC is essential and should cover the following:

- The nature and extent of the hazard(s)
- When protective clothing should be worn
- What protective clothing is necessary
- Use and limitations of the protective clothing to be provided
- How to properly inspect, don, doff, adjust and wear the protective clothing
- Decontamination procedures if necessary
- Signs and symptoms of over exposure or clothing failure
- First aid and emergency procedures
- The proper storage, useful life, care and disposal of protective clothing

## **8.4 GLOVES AND DERMAL CARE**

### **8.4.1 Dermal Exposure**

The Generic term “chemical dermal hazard” refers to chemicals that can either

- cause dermatitis or otherwise damage the skin, or
- enter the body through intact skin and produce internal toxic effects

While both of the above effects are of concern in the workplace, the *skin* notation in the various occupational exposure standard lists is based only on the second of these effects. Properties such as causing irritation, dermatitis and sensitisation in workers are literally not considered relevant when assigning the skin notation. (Popendorf 2006)

Dermal exposure can present a significant pathway for some contaminants to enter the body. This is especially the case with pesticides, but other compounds can be absorbed this way.

Dermal exposure evaluation methods have been broadly categorised into direct and indirect methods.

- ***Direct***

Direct means assessing what is deposited onto the skin; indirect means estimating dermal dose either as attributable to some biologic indicator that is actually measured or that which could potentially result from a contaminant measured on an accessible surface.

The most common direct method is the use of dermal dosimeters in the form of patches. Other direct evaluation methods include skin washes and wipes, and the video detection of fluorescent tracers.

- ***Indirect***

Indirect methods refer primarily to measuring a biologic response such as cholinesterase activity in blood or urinary excretion, but also include measuring surface contamination.

In comparison to air sampling and even biological monitoring, dermal dosimetry is not a simple or routine procedure.

An individual applying dermal dosimeters should be thoroughly trained regarding the placement and retrieval of the dosimeters and recording of observations and other information about the activity. In addition to objective parameters, observed work practices can also have statistically significant influences on dermal exposure.

Each patch dosimeter is a sandwich holding a passive matrix (like a cotton gauze sponge) flat and to protect it from skin perspiration. Either one or two sets of patch dermal dosimeters can be used. The most important is the set placed against the skin under the clothing. It is believed that errors will result from using patch dosimeters attached to the inside of clothing that is free to move relative to the skin; such dosimeters will neither collect contaminants reaching the skin via penetration through openings (such as the neck, sleeves, or cuffs) nor be affected by the air motion carrying contaminant through the weave of the fabric. A second set of dosimeters may be placed outside of any clothing; it is also important that no inner dosimeter is placed beneath an outer dosimeter.

After dosimeters have been in place throughout an activity involving exposure, they are carefully removed, prepared for extraction (the quantitative removal of the chemical from the collection matrix), and the extract is analysed for the mass of chemical.

Whole body dosimeters are typically a set of long cotton underwear that minimises the effect of non-uniform depositions within a body part, but suffers from the lack of a barrier between the skin and dosimeter and may add heat stress to the wearer. After use, the whole body dosimeter may still be dissected into portions covering individual body parts.

As with all other approaches to assessing dermal exposures, there are limitations to the use of dermal dosimeters. Among the most important of these limitations (not restricted to dermal dosimeters) is the difficulty in accurately collecting depositions of volatile chemicals.

Biological monitoring to assess dermal exposure is a common technique (eg: cholinesterase activity in blood for pesticides); however it may be invasive and unless correct sample collection techniques are observed may grossly underestimate exposure. In such cases dermal dosimetry (patches) may be a good alternative.

In other cases (Tetraethyl lead) where skin absorption is a significant exposure pathway, a combination of environmental monitoring and biological monitoring may give the most accurate picture of employee exposure.

Irrespective of the circumstance, dermal monitoring should only be undertaken by persons trained and experienced in the appropriate monitoring techniques.

#### **8.4.2 Occupational Protective Gloves**

Occupational protective gloves as the name suggests refers to the need to provide hand protection against hazards experienced in the workplace. As with the other types of PPE there are a number of International Standards (ISO) and other Standards for gloves from areas including Europe, UK, USA and Australia.

Typically these Standards provide recommendations on the general selection, use and maintenance of gloves in addition to determining the level of performance when assessed against Standard Test Methods. There are standards covering the:

- General requirements for all gloves for:
  - Ergonomy
  - Glove construction
  - Innocuousness
  - Cleaning
  - Comfort and efficiency
  - Marking and information
- Protection from mechanical risks eg: protection against cuts and stabs, tearing, puncture and abrasion etc
- Protection from heat and cold
- Protection from ionising radiation and radioactive contamination
- Protection against chemicals

#### **8.4.3 Protection Against Chemicals**

Protective gloves are available in a wide range of natural and synthetic materials and there is no single glove material or even a combination of materials that can provide unlimited resistance to either a single or a combination of chemicals. The protective glove will, at some stage, fail to protect the wearer from exposure to the chemical hazard by three means:

- Permeation whereby a chemical agent moves through the protective glove material at molecular level. Permeation involves the following steps:
  - Absorption of molecules of the chemical into the contacted (outside) surface of a material
  - Diffusion of the absorbed molecules in the material
  - Desorption of the molecules from the opposite (inside) surface of the material

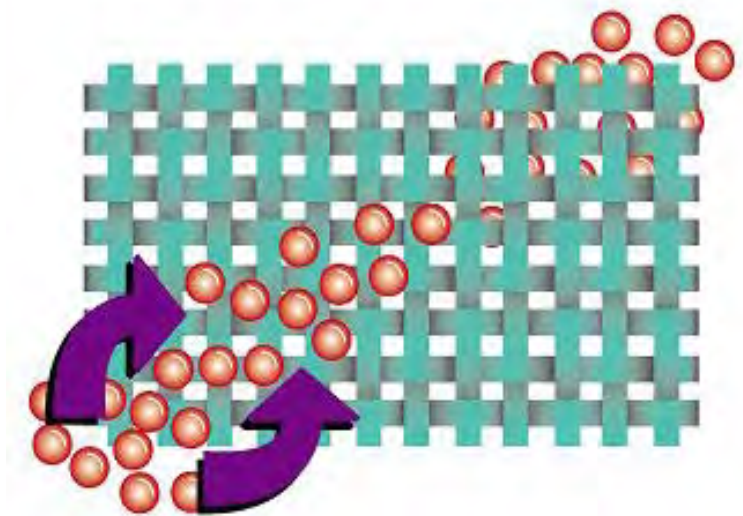

(Source: Ansell Limited – reproduced with permission)

**Figure 8.17 - Permeation**

- Penetration whereby the movement of a chemical and/or micro-organism through porous materials, seams, pinholes or other imperfections in a protective glove material on a non-molecular level
- Degradation whereby there is a deleterious change in one or more physical properties of the protective glove as a result of contact with a chemical. These changes include flaking, swelling, disintegration, embrittlement, discolouration, dimensions, appearance, hardening, softening etc

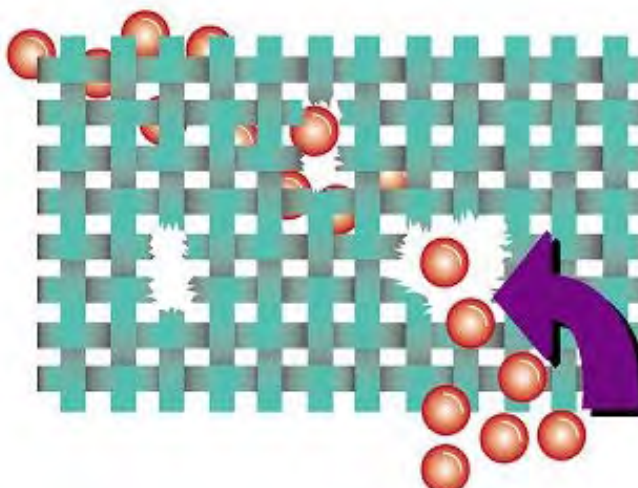

(Source: Ansell Limited – reproduced with permission)

**Figure 8.18 - Degradation**

The resistance of a protective glove material to permeation by a solid or liquid is determined by measuring the breakthrough time of the chemical through the glove material.

Each combination of protective glove/test chemical is classified, in terms of breakthrough time, according to each individual chemical for which the glove prevents permeation.

The results of permeation tests are often expressed in two ways as breakthrough times or as breakthrough rates.

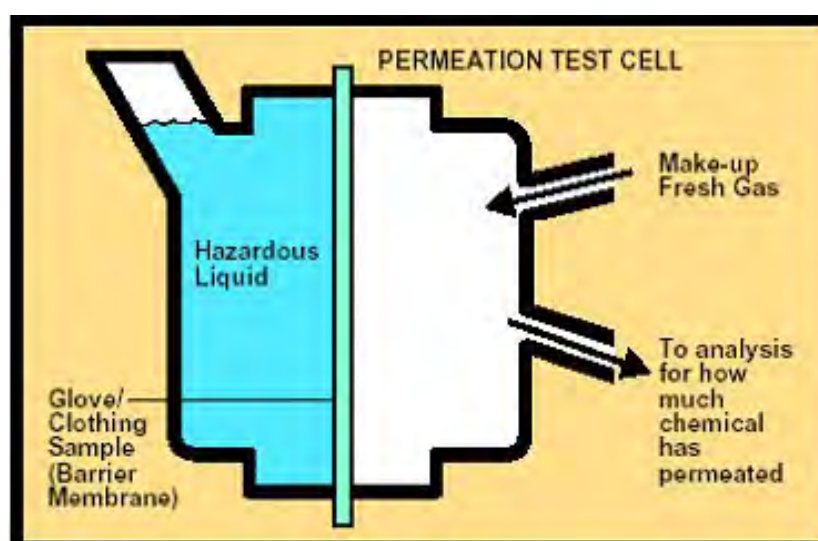

(Source: Ansell Limited – reproduced with permission)

**Figure 8.19 – Permeation Test Cell**



Penetration tests are also performed on gloves.

The principle is based on two tests:

- Air leak test is the primary leak test

The glove is immersed in water and its interior is pressurised with air. A leak is detected by a stream of bubbles outside the glove.

The immersion time shall not be less than 30 seconds and the glove is immediately examined for water leaks.

If this test proves unsuitable, eg: glove is over-inflated in some parts and under or not inflated in other areas, then a secondary test (water leak test) is carried out.

- Water leak test

The glove is filled with water and a leak is detected by the appearance of water droplets on the outside of the glove.

The glove is immediately examined for water leaks.

Degradation tests are performed in the following manner:

Films of test materials are made. These films are weighed and measured and then completely immersed in the test chemical for 30 minutes. The percentage change in size is determined and the films then dried to calculate the percentage of weight change. Observed physical changes as described earlier are also reported. Ratings are based on the combined data.

Resistance to degradation is usually reported on a poor to excellent rating scale.

A question often posed is “Why is a product with a shorter breakthrough sometimes given a better rating than one with a longer breakthrough time?”

Ansell (2007) have provided the answer to this question:

**Why is a product with a shorter breakthrough time sometimes given a better rating than one with a longer breakthrough time?**

One glove has a breakthrough time of just 4 minutes. It is rated “very good”, while another with a breakthrough time of 30 minutes is rated only “fair”. Why? The reason is simple: in some cases the *rate* is more significant than the *time*.

Imagine connecting two hoses of the same length but different diameters to a faucet using a “Y” connector. When you turn on the water, what happens? Water goes through the smaller hose first because there is less space inside that needs to be filled.

But when the water finally gets through the larger hose it really gushes out. In only a few minutes, the larger hose will discharge much more water than the smaller one, even though the smaller one started first.

The situation is similar with gloves. A combination of a short breakthrough time and a low permeation rate may expose a glove wearer to less chemical than a combination of a longer breakthrough time and a much higher breakthrough rate, if the glove is worn long enough.

*(Reproduced with permission)*

#### 8.4.4 Selection of Gloves

The selection of chemical protective clothing and gloves is not a simple matter. For example while a material such as a PVA (Polyvinyl Alcohol) will provide protection from submersion in a range of toxic and dangerous chemicals, the same PVA glove will dissolve in water.

There are Standard Test Procedures to assist in predicting the permeation, penetration and degradation of specific glove materials by specific chemical agents and more detailed information should be obtained from the manufacturer.

There are however four overriding conditions for the selection of any glove for use in the control of hazardous substances. They are:

- Be appropriate for the risk(s) and situation where they are to be used
- Take into account the ergonomic requirements and state of medical health / medical condition of the wearer
- Fit the wearer correctly
- Prevent or control the risk or hazard without adding to the overall risk when being worn

Therefore selection of the correct glove must take into account the wearer, the workplace conditions and the glove itself. Employees need to be educated and trained as to why the particular glove is required, how to correctly put the glove on, how to wear it and after use how to remove it to ensure maximum protection from the chemical(s) is provided. After use contaminated gloves must be able to be disposed of in accordance with local requirements.

Gloves must be both selected correctly and worn correctly because:

- The contaminant may get inside the glove, be in contact with the skin and could result in greater exposure than if a glove had not been worn at all
- Wearing gloves for extended periods of time can result in build up of sweat inside the glove resulting in irritation or skin infection
- Wearing latex (natural rubber) gloves can cause allergic reaction to susceptible individuals resulting in the skin disease contact urticaria

#### **8.4.5 Types of Gloves**

Chemical protective gloves are commonly made from the following materials and has been in part summarised by Pependorf (2006) as:

- Natural rubber - Initially, poly isoprene obtained from rubber plants that was refined and dispersed in water to form a latex that could be moulded into a semi elastic membrane. Provides good protection from bases, alcohols and aqueous mixtures, but is poor for oils and organic solvents
- Butyl rubber is a relatively inelastic isobutylene-isopropylene copolymer. Is considered to be good for glycol ethers, ketones and esters, but poor for hydrocarbon and chlorinated solvents
- PVC is a somewhat elastic polyvinyl chloride good for strong acids, bases and salt (most aqueous mixtures) and alcohols, but not good for many organic solvents

- Nitrile is an elastic acrylonitrile and butadiene copolymer, also known as Buna-N or NBR rubber and is considered good for oils, xylenes and some chlorinated solvents
- Neoprene® is a semi elastic polychlorinated iso-propylene and is considered good for oxidising acids, aniline, phenol and glycol ethers
- PVA is polyvinyl alcohol and inelastic and expensive. It is considered good for aliphatics, aromatics, chlorinated solvents, ketones (except acetone), esters and ethers, but cannot tolerate aqueous solutions
- Viton® is a family of expensive proprietary fluorinated copolymers such as hexafluoropropylene and vinylidene fluoride or vinyl fluoride. These are considered good for aromatics, chlorinated solvents, aliphatics and alcohols.
- Laminates are bonded layers of different polymers such as polyethylene and ethylene vinyl alcohol (PE/EVAL): trade names include SilverShield® 4H® and LPC® and are also called barrier or flat film gloves. They are considered to be excellent for a wide variety of solvents, but they are inelastic, are not formed to fit hands and are relatively easily punctured. These limitations are largely overcome by double gloving (wearing one of the elastic polymers over the laminate)

Leather, cotton and canvas gloves are not chemically protective. They can prevent mechanical stress and minor physical injury, but have virtually no chemical protective qualities. They typically retain the chemical and continue to expose the wearer long after the chemical use has ended.

But who is a chemist to know what class or type each chemical is and therefore what glove to use?

The major glove manufacturers have web sites that provide advice on glove material selection to protection against a range of the most commonly used industrial chemicals and often provide additional information in relation to permeation and breakthrough:

- CHEMREST is used by Best Gloves at [www.chemrest.com](http://www.chemrest.com)
- SpecWare™ is used by Ansell-Edmont at [www.ansell-edmont.com/specware](http://www.ansell-edmont.com/specware) (accessed July 2008)
- North Safety Glove Products at [www.pspglobal.com/nfvitongrades.html](http://www.pspglobal.com/nfvitongrades.html) (accessed July 2008)



(Source: Ansell Limited – reproduced with permission)

**Figure 8.20 – Various Glove Types**

#### 8.4.6 Overall Glove Selection Process

The final glove selection process comprises of three steps:

- Glove Material Selection
 

Once the type of glove material has been determined as outlined previously two other factors still need to be taken into account
- Glove Construction
  - A disposable style for very basic protection with frequent changing
  - An unsupported style is longer lasting and where flexibility and dexterity are important
  - A supported style
- Glove Options
  - What length of glove is required?
  - How much grip is required?
  - Are various sizes of glove required?

While it is important to select the correct glove to protect against a particular hazard, comfort must not be forgotten. For example, if the hands inside the gloves become extremely hot or sweaty the gloves are less likely to be worn. Similarly if workers feel they are unable to obtain an adequate grip of a tool or equipment, they may decide not to wear the gloves or mittens. All of these facts must be taken into account in the selection process.

#### **8.4.7 Limitations of Gloves**

It must be remembered that gloves should only be used as the last measure of control where other methods of control are not reasonably practical. Some of the limitations on the use of gloves include:

- Gloves only protect the wearer and do not remove the contaminant from the workplace
- Some types of glove are inconvenient and can interfere with the way the wearer does his work
- Wearing gloves often causes the wearer to lose touch, feel and dexterity
- Protection depends on the correct selection of glove material, a good fit and properly used

#### **8.4.8 Glove Removal**

Most users need to be shown how to remove gloves correctly to prevent contamination of the unprotected skin. Loose fitting gloves can be shaken off quite easily. Tight fitting gloves should be removed by grasping the cuff of one glove and pulling it down and inside out. While the partly removed glove is still on the hand, the other glove is pulled down and inside out without touching the bare skin with any contaminated glove surfaces. The gloves are finally removed with one partly inside the other.

It is not recommended that these gloves are reused because of the risk of introducing contamination onto their internal surfaces. If this occurs the enclosed nature of the glove may increase the rate of absorption of the chemical the gloves were intended to protect against.

Always remember that if the inner surface of a glove becomes contaminated, no matter how much attention has been paid to the correct selection of the glove for the situation, exposure will occur.

For example, if you have to remove more gloves temporarily your hands may become contaminated from handling the gloves. If you put back on the same pair of gloves you transfer the chemical to the inside the gloves and exposure can occur. To prevent this from occurring you should wash the gloves thoroughly before taking them off.

#### **8.4.9 Reuse and Laundering of Gloves**

The AIOH (AIOH 2007) suggest that the re-use and laundering of gloves can be fraught with problems which include:

- Gloves may have small holes that are not detected
- Contaminants can be moved to the inside of the glove during washing
- The washing process can physically damage the glove
- The washing process may not remove any chemical that has started to migrate through the glove material

Skin creams or lotions and hand cleaners may contain petroleum based products that may cause swelling and degradation of the glove material. If there are any concerns specialist advice should be obtained from the manufacturer.

If any deterioration is noticed in glove performance the gloves should be removed and their suitability reassessed.

#### 8.4.10 Training

A successful skin protection programme includes the correct selection of gloves as well as training in their correct use, in the limitations to the protection they can provide and their correct removal without causing contamination of the skin.

To protect the wearer the gloves must be used properly

### 8.5 EYE AND FACE PROTECTION

Eye protection can also be required for protection against hazardous substances in the workplace. In a similar way as to other items of PPE they can be selected in accordance with National and International Standards as well as obtaining recommendations from the manufacturers.

Appropriate eye or face protection is required when exposed to eye or face hazards from flying particles, molten metal, liquid chemicals, acids or caustic liquids, chemical gases or vapours or potentially injurious light radiation.

Eye and face protection is also often required to protect the wearer from:

- Hazardous substances

Face shields or goggles for people handling hazardous chemicals are typically made from either polycarbonates or poly-methyl methacrylate (known as PMMA or acrylic). However, chemical reactions from some vapours can cause normally transparent face shields to become opaque.

Goggles can be of a ventilated or non ventilated type and must be chosen in accordance with the nature of the hazard.



(Source: BOC Limited – reproduced with permission)

**Figure 8.21 – Protective Eyewear**



- Traumatic injury

Protection may be provided by the same face shields and goggles that provide chemical protection.

It must be noted that safety glasses (preferably those with side shields) provide very little protection against chemical particulates or chemical liquid splashes and no protection against eye irritating gases and vapours.

## **9. ADMINISTRATIVE ELEMENTS**

### **9.1 INTRODUCTION**

The term administrative elements or administrative control can be defined very broadly or very narrowly. The AIHA (2003) defines administrative controls in its broadest sense to include management involvement in the training of employees, rotation of employees, air or biological sampling, medical surveillance and housekeeping. On the other hand Pependorf (2006) uses a more narrow definition meaning to reduce the dose of a hazardous agent to one or more employees by limiting the duration that each individual is exposed to that agent, ie an increase in the proportion of the work day that each individual spends in low or no exposures.

Administrative controls (or work practice controls) can also be considered as changes in work procedures such as written safety policies, rules, supervision, schedules, and training with the goal of reducing the duration, frequency, and severity of exposure to hazardous chemicals or situations.

The approach here will be to take the broadest approach and endeavour to consider all aspects of an administrative nature that can assist in the control of hazardous substances.

### **9.2 LEGISLATIVE REQUIREMENTS**

There are Occupational Health and Safety Acts and Regulations such as the Control of Hazardous Substances, COSHH, REACH etc in all countries. In these Acts and Regulations there is a framework under which the obligations of various parties, including both employers and workers, are established. There are obligations of employers towards ensuring the health and safety of their workers by controlling hazards at source. There are also obligations for workers to cooperate with the employer in their own health and safety, plus obligations applying to all traditional safety matters (guarding, electrical, fall prevention, etc) as well as the more difficult matters of occupational health and occupational hygiene (AIOH 2007).

All health and safety laws and regulations, codes of practice and industry standards are effectively forms of administrative control. The way in which administrative controls are put in place will depend on the particular workplace. Company health and safety policy and health and safety procedures and government regulations all have a place and role to play.

### **9.3 REDUCING PERIODS OF EXPOSURE**

Reducing periods of exposure by worker rotation or job placement reduces an individual's exposure by sharing the work amongst several workers. For instance during the internal welding process in pipeline construction it can be both hot together with excessive amounts of welding fume. This could be performed by a team of welders. Multi-skilling of workers spray painting furniture means that time exposed to organic solvents or two pack paints is reduced by swapping to an alternative task such as timber preparation or product despatch.

Job placement incorporates a number of issues in relation to a person's fitness for work and a person's ability to perform the alternate duties.

Where employees have been over exposed to hazardous substances as indicated by results of biological monitoring it will be necessary to remove them from that situation.

For example, in the lead industry, workers may be removed from the lead processing area if their blood lead levels exceed a certain criteria. They are not permitted to return to that task until their levels return to an acceptable level. The same principle is applied to workers exposed to other agents including mercury and pesticides.

In the nuclear industry, workers are permitted a maximum radiation dose in an allocated period of time before they are removed from further exposure.

## 9.4 SCHEDULING OF WORK

It may be possible to reschedule high risk work where the least number of workers are likely to be present. Is it possible to:

- Spray isocyanate based paints, which can cause respiratory sensitisation, on the afternoon shift rather than day shift.
- Remove asbestos lagging material on the weekend rather than during the week.
- Pour molten metal into organic resin foundry moulds on afternoon or night shift.
- Fumigate the building or offices with pesticides on the weekend not during the week.
- Undertake the maintenance on the dust removal system (eg: replace the heavily contaminated bag house dust filters) when the usual production staff are not present.

It should also be noted that on back shifts and over weekends when the dayshift supervisory staff are not present, that “shortcuts and not following the required procedures” can result in unnecessary exposures and incomplete use of existing control procedures.

## 9.5 MAINTENANCE AND HOUSEKEEPING

Insufficient maintenance can result in either a catastrophic releases from a ruptured ductwork system or fugitive releases from slowing increasing rates of leaks from flanges, joint and access doors. Poor maintenance practices may result in the release and escape of material when emission control plant is being repaired or serviced eg: replacement of exhaust ducting and seals, changing of filters etc.

Maintenance itself can cause the generation and release and of excessive amounts of accumulated dust from building support structures such as ledges, columns from the top of ducting etc. PPE is often required to worn in such circumstances. Compressed air must not be used to blow down and clean dusty surfaces.

Maintenance of air cleaning systems, eg: change of filters in baghouses, presents particular issues re the handling of large quantities of concentrated, contaminated and toxic materials.

Dust that has escaped from the process will settle and become a source of secondary exposure when for example the wind blows or traffic disturbs it and it becomes airborne and spreads further away from the initial point of release. Dust is always found underneath conveyor systems and at conveyor transfer points. Where dust accumulates it must be cleaned up regularly. While vacuuming is the preferred method sometimes it cannot be used and sweeping, preferably wet sweeping should be carried out.

Liquid spills must also be cleaned up promptly before evaporation occurs and solvent laden rags and absorbent etc should be placed in sealed bins and disposed of in accordance with local requirements.

The importance of maintaining high standards of housekeeping cannot be over emphasised. Dirty and untidy workplaces not only increase the likelihood of secondary exposures (eg: dust raised by draughts and wind, or inadvertent skin contact on dirty surfaces and equipment) but may also send a message to personnel that poor work habits are acceptable.

## **9.6 ROLE OF EATING, SMOKING AND DRINKING**

Eating, smoking and drinking in the workplace are aspects of personal hygiene that may impact upon potential exposure by inhalation. The classic example is that of a lead worker who is a smoker. In this situation, if the worker's hands are contaminated with lead dust, the dust is transferred to the cigarette and as it is volatilised by the burning cigarette it is inhaled. The same principle applies to other hazardous chemicals including pesticides.

Accidental ingestion of chemicals can also occur by eating food without first washing the hands or drinking from a contaminated source such as drink fountain located in the middle of the work area.

## 9.7 CHANGING FACILITIES AND CLOTHING STORAGE AND LAUNDERING

Change facilities in the coal mining industry have traditionally had a “clean” and a “dirty” side (Figures 9.1 and 9.2).



(Source: D Moore – reproduced with permission)

**Figure 9.1 – Clean Side of Coal Mine Change Room**

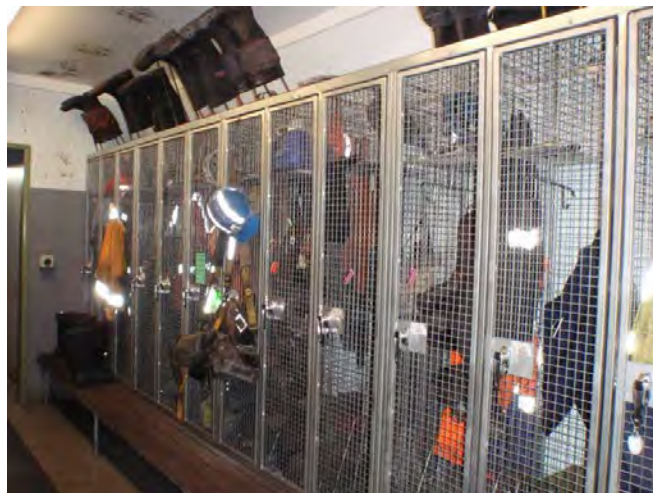

(Source: D Moore – reproduced with permission)

**Figure 9.2 – Dirty Side of Coal Mine Change Room**

When the miners arrived at work they would remove and store their clean street clothes in lockers on the clean side of the facility and pass through a shower area to the dirty side where they would dress in their often already dirty work clothes and proceed underground.

On return from underground, they would remove their dirty clothes leave them in the dirty side lockers, shower in the middle section and proceed through to the clean side where they would put on their street clothes and leave work.

At some time, the dirty clothes required laundering. This was done by either taking the clothes home for washing or was undertaken by the employer.

The same procedures are typically adopted in the lead and nuclear industries to prevent the spread of contamination from the workplace. In these industries it is common practice that the contaminated or potentially contaminated clothing is laundered either on site or taken offsite and laundered under special and controlled circumstances.

It must be noted that shaking out of dusty clothes after removal is a common practice and causes a completely unnecessary secondary exposure to the contaminant. There are well documented cases of housewives who have contracted asbestos related lung diseases with no known exposure to asbestos except from the laundering of asbestos contaminated work clothes brought home for washing.

## **9.8 SHOWERS AND WASH HAND BASINS AND THEIR ROLE IN PREVENTING EXPOSURE**

Personal hygiene of workers is an important issue in regard to controlling accidental exposures. As indicated earlier employees hands may become contaminated and result in secondary exposures to the material by inhalation if they are a smoker or by ingestion if they eat in the work place without first thoroughly washing their hands to remove the potential sources of exposure.

Workers whose hands become soiled during the course of their duties must be encouraged to wash their hands frequently to prevent this exposure from occurring.

Similarly after work it should be a requirement that such employees shower effectively to remove contaminants from their body and paying particular attention to the washing of the hair.

Adequate wash basins and suitable shower facilities need to be provided and satisfactorily maintained by the employer.

## **9.9 USE OF CREAMS AND LOTIONS**

There are a number of creams and lotions on the market as an alternative to the use of gloves. These are typically intended for materials with irritant or low dermal toxicity. There is a range of products which typically fall into types:

- Water repellent barrier creams for protection against either water or water soluble agents
- Solvent resistant barrier creams for protection against oils and solvents

Both of these two types require regular and periodic reapplication. It is not recommended that barrier creams be used on damaged skin.

Barrier creams, for example, have been used in an endeavour to prevent erythema or reddening or burning of the skin on exposure to UV light after contact with coal tar pitch based products. As with the use of all barrier creams it is imperative that they are applied evenly over the entire exposed skin surface. Areas missed during the application will be affected.

Australian Standard AS/NZS 2161.1 advises that caution should be exercised when using barrier creams and protective films as a number of studies indicate that they may cause an increase in the rate of absorption of some organic solvents. Even where barrier creams and protective films have been shown in some laboratory or market trials to give protection against a range of chemicals, caution should be exercised in their use. Problems of inadequate coating through either poor application or wear in use are issues of real concern, as well as lack of data about all possible conditions of use.



If a barrier cream is chosen consult with the manufacturer to ensure its suitability for the type of chemical being used.

It is generally considered that barrier creams and lotions are not an effective replacement for correctly selected and properly worn gloves.

#### **9.10 CONTROL OF ACCESS TO HAZARDOUS AREAS**

Where hazardous areas have been defined procedures need to be in place to exclude non essential personnel from entering the area and measures could include:

- Sign posting
- Entry log book
- Swipe or access card system
- Security personnel

#### **9.11 THE ROLE OF ASSESSMENT, MEASUREMENT, MONITORING AND HEALTH SURVEILLANCE IN INITIATING CONTROL MEASURES**

Before control measures can be properly implemented a thorough knowledge of the hazard is required and;

- How the hazardous situation arises
- What the exposed people are doing when they are exposed
- Why they are doing the task
- What are the intended outcomes of the control programme or task
- What the impacts on other people nearby are and, importantly
- What the consequences are if the controls are not adequate or fail to protect the worker. (AIOH 2007)

These are all elements of an effective Occupational Hygiene Programme. For each work area, process or occupation a workplace assessment is carried out. This identifies potential chemical, physical and biological hazards that may impact the health of the worker.

The workplace exposure monitoring results should contain information describing the conditions in the workplace that relate to the intensity, duration and likely exposure routes (inhalation, ingestion and skin absorption or contact) of these exposures.

This information is evaluated and appropriate recommendations made that may require further workplace monitoring, biological monitoring or initiation of health surveillance programmes or need for the introduction of control measures.

#### **9.12 ROLE OF WRITTEN OPERATING PROCEDURES, PERMITS TO WORK ETC**

Look at ways and examples of instituting exposure reducing work practices in written operating procedures, job method statements and as topics for safety meetings and tool box talks held just prior to the start of the shift.

If the requirements are written down it is then clear for all personnel the hazards associated with particular tasks and what controls need to be used for the work to be done safely.

Safe working practices are administrative requirements and procedures to ensure that employees work in a safe manner. Safe working procedures become an integral part of the process. Examples of safe working practices may include:

- Good housekeeping programme to ensure regular decontamination of walls and floors
- Good personnel hygiene requirements by prohibiting eating, drinking and smoking in contaminated areas, or by providing shower and washing facilities for personal decontamination
- Reducing the number of exposed employees and restricting access to non essential workers to the contaminated areas
- Providing for the safe storage and disposal of hazardous substances

- Establishing effective emergency procedures and test these procedures regularly through planned exercises
- Investigating every incident, accident or near miss and rectifying the cause to ensure it does not happen again
- Establishing an adequate induction and training programme to ensure employees are aware or can identify the hazards and are fully conversant with the proper use of control equipment and procedures involved
- Enforcing safe work practices recommended by the suppliers or developed in the workplace
- Establishing a programme for reducing stored chemicals
- Establishing a programme for waste minimisation

### **9.13 ROLE OF OCCUPATIONAL HYGIENE PROGRAMMES IN CONTINUING CONTROL**

Once workplace control measures have been introduced they need to be maintained or they will become ineffective.

- Exhaust ventilation systems and other engineering controls must be routinely inspected to measure their effectiveness by, for example, measuring the face velocities, or verify the operation and maintenance of the exhaust fans
- Are routine occupational hygiene monitoring or biological monitoring programmes or medical surveillance programmes required?
- Where respiratory protective equipment is used, check the maintenance of SCBA units, establish and audit cleaning procedures and respirator filter change schedules or perform fit testing
- Where chemical protective clothing and gloves are used ensure their use and adequacy for the task

It is important to document the maintenance and audit practices undertaken to demonstrate that the controls are indeed satisfactory.

#### **9.14 IMPORTANCE OF EDUCATION, INSTRUCTION AND TRAINING**

To be able to use administrative elements effectively workers need to be adequately trained.

They need to know:

- Why the control is needed
- How the control is to be achieved
- The limitations of such procedures
- The consequences of not adhering to the controls

To achieve this effectively, it is critical that the workers, including their supervisors, actively participate in the development, implementation and training related to the use of administrative control measures.

#### **9.15 EMERGENCY PROCEDURES AND FIRST AID IN HIGH RISK AREAS**

PPE is important in dealing with emergencies and in providing first aid in high risk areas. Mine explosions, industrial fires, gas leaks and response to terrorism type activities are all situations where the preferred engineering control measures of ventilation cannot be used and as such sole reliance is placed on PPE.

In some circumstances it may be the same PPE that is used in the particular work environment where the incident has occurred, but often, where the contaminants themselves are unknown, where their levels are also unknown, possibly occurring in confined spaces or where fires are burning it will be necessary to wear more specialised equipment such as SCBA, fully encapsulating chemical suits or fire resistant clothing.

The PPE for dealing with such situations must be stored where it is immediately ready for such events, but be in such a place that it is both accessible and not damaged by the event or accident causing the emergency. This requires careful and thorough emergency management planning prior to the anticipated events that might give rise to such a situation.

When items are stored they can and do deteriorate over time, they are “borrowed” for use with a view to replacing them immediately, but how often are they replaced? Materials have use by dates, shelf lives, may have particular storage requirements of keep refrigerated, or in a cool dry place; items can and do deteriorate over time, batteries for example go flat. It is important to establish and carry out an inspection and testing schedule for all the listed inventory items.

Much of the required equipment eg: SCBA is complex and requires specialised training in its use. An untrained person attempting the rescue of a person in a toxic environment is likely to become a casualty.

Personnel need to undertake regular refresher training in response to anticipated emergencies involving the use of the PPE and all other equipment likely to be used in the emergency. Personnel move away or retire; equipment changes so an effective emergency management plan incorporating the use of PPE must be in place.

## **9.16 TRAINING**

To be able to use administrative elements properly workers have to be adequately trained so they know:

- Why the administrative element of control is being used
- The exact procedures and guidelines to be followed
- The limitations of such administrative controls
- The consequences of ignoring the administrative elements

Involvement of workers in the recognition, design and implementation of controls is useful in several ways:

- It promotes consultation between employers, supervisors and workers
- Workers feel a sense of ownership and empowerment of decisions that they have been involved with

- Job satisfaction may increase in the realisation that workers' opinions are valued and sought after
- Workers have intimate knowledge of the workings of a process or system, and whether the controls are practicable and useful
- Cultural and any language issues need to be addressed as required, depending on the particular circumstances

So in summary, worker involvement, participation, training and education are critical in the success of administrative elements for the control of hazardous chemicals in the workplace.

## **10. PRACTICAL APPLICATIONS OF CONTROL STRATEGIES**

### **10.1 INTRODUCTION**

The aim of this section is to bring together the information of the previous sections in the form of a series of case studies. All are real situations and highlight various aspects of control strategies.

It is important to understand that no overall encompassing control strategy exists (except for the total elimination of the hazardous substance) and that each workplace needs to be evaluated and an appropriate control approach designed and implemented. Once implemented, the strategy needs to be maintained.

### **10.2 ADDITION OF HYDRATED LIME TO CYANIDE TANKS**

At a carbon-pulp gold processing plant in Equatorial Africa, the need arose to make routine additions of hydrated lime ( $\text{Ca}(\text{OH})_2$ ) to the cyanide extraction tanks in order to control pH. To do this the mill decided to use bulk hydrated lime delivered to the site in 1000 kg bulk bags so as to minimise transportation costs.

The pH in the tanks was monitored and when required a 1000 kg bag was lifted by crane above a chute which had an internal spear to pierce the bag and release the hydrated lime to the cyanide mixing tanks below.

As can be seen in Figure 10.1 this process generated significant levels of dust which was inadvertently blown over the operator by variable equatorial winds. Reference to the product MSDS indicated that the material was corrosive by inhalation, ingestion, skin and eyes. Moreover inhalation would result in severe mucous membrane irritation of the nose and throat and prolonged and repeated contact with the skin would result in a severe skin rash, dermatitis and possible chemical ulceration.



(Source: University of Wollongong)

***Figure 10.1 – Loading Hydrated Lime into Chute above Cyanide Mixing Tanks***

When the process initially commenced, operators experienced respiratory irritation and due to the hot humid equatorial climate, severe skin irritation and in one case, ulceration.

The response of the mill manager (an expatriate from North America) was to supply respiratory protection and impervious raincoats so that the product didn't contact the skin. This was a practice that had previously been used during an emergency at a mill in a cold North American location.

Almost immediately that these procedures were introduced the number of heat stress cases presenting to the onsite clinic increased. Upon investigation it was realised that the combination of impervious raincoats and a hot equatorial climate had resulted in the operators' core body temperature increasing to the point of heat stress onset. This had not occurred in the North American location when the same approach was previously used, due to the cold climate.



Management response was to temporarily cease the addition of the hydrated lime in bulk bags until a series of fine water sprays could be installed inside the delivery chute. Once the spray system was activated the fine dust arising from the opening of the bags was contained, eliminating the need for any personal protective equipment.

The key learning in this situation was that solving one problem can create another and what may work in one situation can be dangerous in another.

### **10.3 RESPIRABLE SILICA EXPOSURE DURING SAND BLASTING**

Sand blasting (or more correctly, grit blasting) is a common practice in industry to prepare steelwork for painting, welding or further processing.

The term “sand blasting” is derived from the period when river or beach sand was forced at high pressure through a nozzle so as to clean surfaces. The high velocities involved resulted in the sand particles fracturing, thus reducing the particle size to the point that it could be respired by the operator. Many operators of such systems who were not adequately protected suffered silicosis and in some cases, death.

To overcome this problem, statutory authorities in many countries banned the use of sand, and low silica products such as garnet, ilmenite and copper slag were substituted.

Figure 10.2 highlights a situation where a contract company failed to observe the statutory requirements and in addition did not consider all potential exposures.



(Source: University of Wollongong)

**Figure 10.2 – Sand Blasting Steel Pipes**

Regarding the situation indicated in Figure 10.2, an occupational hygienist was visiting a construction site and observed significant dust clouds arising from a grit blasting operation. Upon closer investigation it was found that the material being used in the process was a fine dust containing 35% w/w crystalline silica as it was a cheap source of blasting material. The airline respirator being used by the operator was found to be in poor condition and the air compressor being used for the blasting process was also the air supply for the air supplied respirator. No air quality monitoring results from the supplied air could be found. Discussions with the operator's assistant indicated that it was not uncommon for the dust cloud from the blasting operation to drift over the position where he was shovelling the silica material into a supply hopper. No respiratory protection had been supplied to this person.

As a result of these observations the occupational hygienist consulted with the site management and the process was immediately stopped.

Discussions with the contractor resulted in the high silica blasting material being replaced with a more appropriate product, the supply of an independent air source for the airline respirator along with regular air quality monitoring, construction of a wind barrier between the blasting area and the supplier hopper to minimise wind drift and an educational programme being introduced for all involved.

While this may well have been an isolated event it does serve to highlight a number of key points. These include:

- The need to understand the nature of products being used in a process and the effect the process may have in increasing the risk of a health hazard.
- Consideration needs to be given to all potentially exposed workers not just those in the near area.
- Maintenance of PPE is a priority if the expected level of protection is to be achieved.

#### **10.4 VENTILATION IN A LABORATORY SAMPLE ROOM**

Following complaints from laboratory technicians working in a sample preparation room regarding high levels of noise and dust, an inspection was undertaken by an occupational hygienist.

Upon attendance, the occupational hygienist found the ventilation system to be somewhat of a “jigsaw puzzle” in that there were numerous branches off a main duct leading to grinding mills and furnaces all connected to the one fan (Figure 10.3).



(Source: University of Wollongong)

**Figure 10.3 – Laboratory Ventilation System Ducts**

Closer examination indicated some unusual design features (Figure 10.4 & 10.5).



(Source: University of Wollongong)

**Figure 10.4 – Ductwork for Extraction System**



(Source: University of Wollongong)

**Figure 10.5 – Close-up of “T” Joint in Ductwork**

As can be observed, this design is not consistent with good practice and would create significant turbulence and thus noise.

Examination of the ductwork leading from the grinding mill booth and furnaces (Figure 10.6) indicated a complex duct design with no balancing of the system apparently having been undertaken. This was confirmed via the use of a smoke tube and anemometer, which indicated that the majority of the air was traversing the duct closest to the fan and little airflow was present in the other branches. This accounted for the high dust levels present when crushing samples in some mills.

The fan was found to be in poor condition and not matched to system requirements.



(Source: University of Wollongong)

**Figure 10.6 – Complex Ductwork**

No records could be found as to the origins of the system, however the design suggested it had been installed by someone who had little knowledge of ventilation. Maintenance and system performance records could not be found. It was also apparent that as the laboratory had expanded, the ventilation system had been extended without due consideration of the size of the fan, duct design or the extensive duct branching.

Unfortunately, the situation above is not uncommon and serves to highlight that any ventilation system should be fit for purpose and simply adding another branch can upset the whole system.

The key learnings from this exercise are:

- Ventilation systems need to be designed to meet the individual process needs

- Implementation of a ventilation system is not the end of the exercise. Good maintenance practices need to be observed
- System performance needs to be regularly monitored

## 10.5 MERCURY EXPOSURE IN A GOLD ROOM

The final stage of extracting gold from ore using the carbon-in-pulp method is to smelt the recovered elemental gold so as to remove impurities. The smelting process involves heating the raw gold in a natural gas furnace and creating a slag on the surface of the molten gold using various minerals. Many impurities transfer from the gold to the slag under controlled metallurgical conditions but others (eg: mercury) are released to the atmosphere as a vapour.

At the appropriate time the gold is poured (Figure 10.7), cooled, identified and sent to a specialist refinery for further processing.



(Source: University of Wollongong)

**Figure 10.7 – Processing Gold**

From the photograph it is possible to see that the furnace is located under a canopy type hood which is linked to an extraction fan outside the building. The purpose of an extraction system is threefold.

- To remove any combustion gases during the heating of the gold matter by natural gas
- To remove any contaminants from the gold during smelting
- To remove hot air within the secure gold room so as to make the environment more pleasant for workers overseeing the six hour daily smelting process

Following complaints from workers an examination of the gold room was undertaken. Initial findings were that there were elevated levels of mercury present in the atmosphere (albeit below the exposure standard), capture velocities of the canopy hood were low and that there was minimal air movement within the gold room.

Examination of the fan established that the belts between the drive motor and the fan impeller shaft were continually “slipping”, thus decreasing the degree of extraction. Closer examination of the outer fan housing and ductwork found significant openings due to corrosion (the fan was not protected in the harsh equatorial climate) again reducing the efficiency of the system.

Repairs were made to the system with a resultant improvement in capture velocities. Mercury levels were no longer detected, and while the airflow in the gold room increased it was not at a level that was expected. Inspection of air intake vents for the air supply system established that many were blocked, thus limiting the amount of make-up air entering the gold room. Once these were cleared, air movement within the gold room increased.

The key learning from the above situation is that most control strategies require maintenance and ventilation systems are all prone to failure if adequate maintenance is not maintained.



A simple routine check of the face velocity of the hood would have highlighted the drop off in efficiency as the belts “slipped” but unfortunately no routine testing was in place.

## **10.6 MANUFACTURE OF PHTHALIC ANHYDRIDE**

Phthalic anhydride is an important bulk chemical and is used in the manufacture of phthalate ester plasticisers, polyester formulations for boat hulls, glass reinforced plastic applications and in alkyd resins for paints.

Over 85% of commercial phthalic anhydride is produced from o-xylene by gas phase oxidation using vanadium pentoxide as a catalyst. The final product is sold in bulk bags of 500 kg or 1,000 kg capacity, road tanker and 25 kg bags as a flaked solid. The product is also sold in the molten form and transported in insulated road tankers. Phthalic anhydride has the following physical properties:

- White solid at room temperature
- Melting point of 131°C
- Saturated vapour pressure of 1 mm Hg @ 96.5°C

Phthalic anhydride is a known respiratory sensitiser with established workplace exposure limits.

In this case study, concern was raised as to the potential exposure of workers during the filling of bulk bags with phthalic anhydride immediately after manufacture.

An initial survey by an occupational hygienist found the following:

- The production process operated 24 hours with the section producing flaked solid being the main area for potential exposure of workers
- Some process problems in product quality of flaked solid resulted in solidification in bulk bags, thus requiring reprocessing (and subsequent rehandling)

- The local exhaust ventilation system for dust control was very limited and subject to regular failure. In addition the system was not designed in relation to the capture and transport of phthalic anhydride dust and fume
- Bulk bag system was designed for 1,000 kg bags; however changes in customer demand resulted in an increased use of the system for 500 kg bags with increased handling and thus potential for increased exposure. Employee exposure arose due to the requirement for manual intervention in the process to connect, disconnect and tie-off bags
- All workers were observed to be complying with the personal protective equipment standards of the site. These included eye protection, overalls and respiratory protection. The area was also a designated hard-hat area

As part of the initial survey some preliminary monitoring for phthalic anhydride was undertaken. This monitoring indicated that long term exposures ranged up to a maximum of 4.1 mg/m<sup>3</sup> during bag filling operations. As the statutory exposure limit was 4.0 mg/m<sup>3</sup> appropriate action was required to reduce employee exposures.

The approach to establish what exposures needed to be controlled and how they could be controlled was systematic, scientific and involved stakeholders. Some key actions were:

- Detailed task observation and measurement to identify the main exposure sources and routes within the bag system. Figure 10.8 shows the tie-off process of a filled bag with the potential for exposure during this process



*(Reproduced with permission)*

**Figure 10.8 – Tie-off Process of Filled Bags**

- The use of simple techniques such as the dust lamp (Tyndall beam) to identify phthalic anhydride fume loss from bags (Figure 10.9). Targeted workplace monitoring was also undertaken to confirm these observations.



*(Reproduced with permission)*

**Figure 10.9 – Dust Lamp used to Highlight Fume Loss from Bags**

- In association with the bag supplier the following improvements were made:
  - Redesign of bags to include double seams
  - Lined bags
  - The repositioning of the tie point to avoid the need to lean under the extraction system to tie-off filled bags
- Modifications were made to the flaking process to produce solid sheets of solidified phthalic anhydride which were then turned into flake using a mechanical nibber. This overcame the problem of solidification in the bulk bag and subsequent rehandling
- Introduction of a new local exhaust ventilation system designed for the requirements of the process (Figures 10.10 & 10.11). An improved level of automated bag filling was also introduced which removed a significant number of practical and manual handling issues



*(Reproduced with permission)*

**Figure 10.10 – Effective Ventilation System**



*(Reproduced with permission)*

**Figure 10.11 – Local Exhaust Ventilation During Bag Filling**

Resampling, following the above improvements, saw personal exposures to phthalic anhydride drop to 0.2 – 0.4 mg/m<sup>3</sup>. Examination of bags using both visual and the Tyndall beam showed little dust or fume leakage from the bag seams.

As part of an ongoing control assurance process, annual workplace monitoring was undertaken and a health surveillance scheme introduced for plant operators. Pre-employment screening of new workers for this plant was also introduced.

The key learnings from this case study include:

- Visual observation and simple techniques can highlight potential employee exposures
- A systematic approach to developing suitable control strategies is very effective

- The involvement of stakeholders (including suppliers) can lead to significant improvements and lower exposures
- Process modifications may be necessary in order to control exposures

## 10.7 CONTROL OF POWDERS IN THE PHARMACEUTICAL INDUSTRY

In the pharmaceutical industry there is a constant need to transfer powders from one form of container to mixing or reaction vessels. This case study details two situations where problems arose in the process of manually handling powders.

### Situation A

In this situation an operator is removing pre-weighed bags (about 5 kg) of powder from a cardboard container before lifting and tipping the material into a chute connected to a mixing vessel (Figure 10.12). The operator is wearing a Tyvek suit with a separate hood. The hood is fed with breathing air, taken from the local area by a battery operated pump and filtered.



*(Reproduced with permission)*

**Figure 10.12 – Manual Handling of Pharmaceutical Powder**

The problems with this situation were identified as:

- The work area is open allowing dust from the powder to travel and collect on ledges, machinery, etc
- Persons working in the area or walking through the area during the loading operation are at risk of exposure to the airborne material if they are not also wearing appropriate respiratory protection
- Some powders, when airborne, are easy to ignite and may generate a lot of energy causing injury and damage. Local electrical systems (agitator motor) may have sufficient energy to ignite a dust cloud or dust layer dependent on the characteristics of the powder and the design safety category of the electrical equipment
- Dust layers can be disturbed and inhaled by others later who are not wearing protective equipment for supposed “safe” activities such as equipment checks (maintenance). They may react with moisture or other materials in the air to change their character sufficiently to pose additional risks (chemical burns). They may fall onto exposed skin or into eyes or may be transferred by hand to the mouth or other surfaces such as door handles and light switches

Following an exhaustive evaluation of the above problems the following strategy was implemented.

The powder was pre-weighed into containers which could “dock” with the vessel thus enabling a controlled transfer. Easy flowing powders can be weighed into rigid containers and those which do not flow so well into flexible containers (Figures 10.13 & 10.14); both being fitted with connectors which allow connection to fixed docking ports on the vessel (Figure 10.15).

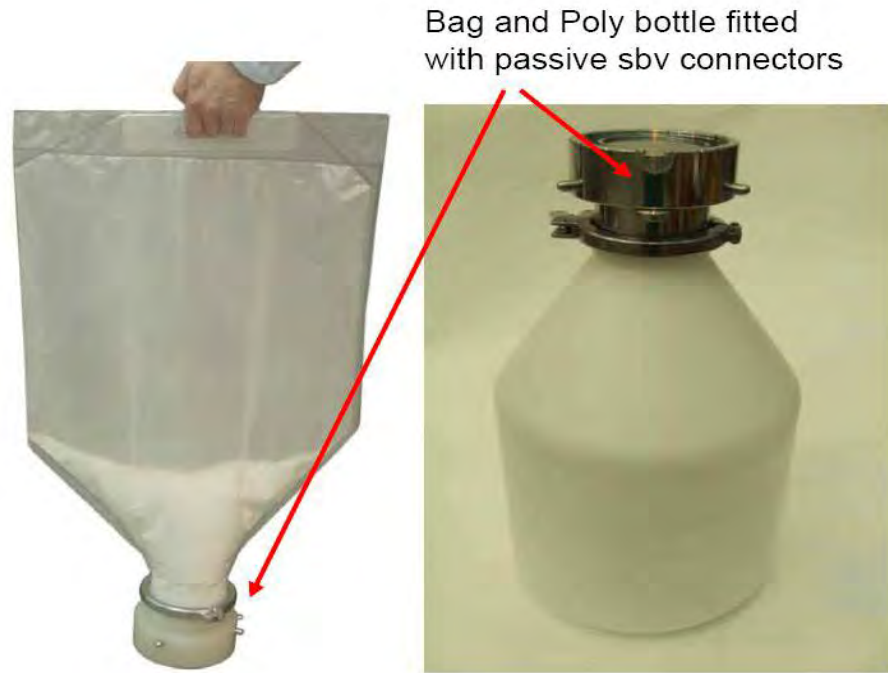

*(Reproduced with permission)*

**Figure 10.13 – Pre-weighed Containers**



*(Reproduced with permission)*

**Figure 10.14 – Pre-weighed Container in Discharge Position**





*(Reproduced with permission)*

**Figure 10.15 – Fixed Docking Port on Mixing Vessel**

While this solution does involve some capital cost, the docking bags and containers are reusable and have a reasonable life.

There is a risk of some material being released when the two halves of the device are undocked. Suppliers of such devices can provide a range of valves and add-ons to tackle this, ranging from local air extraction to gas, or liquid washing between the faces of the docking device before undocking. These can give very low releases (<1 microgram/m<sup>3</sup>). “Home made” systems using two valves and washing between them before disconnecting can also be used.

### **Situation B**

This situation is much the same as the previous one, however there is requirement to load significantly larger quantities (up to 25 kg) into a dissolving vessel (Figure 10.16).



*(Reproduced with permission)*

**Figure 10.16 – Loading Material into a Dissolving Vessel**

In this case there is no chute around the man way which is used for loading but some local exhaust ventilation has been provided nearby. The personal protective equipment is similar to that used by the worker in Situation A and the operating area is an open area of the workplace.

If the approach adopted in Situation A was applied here, the greater volumes of material involved would mean repeated small loading operations, giving rise to potentially increased exposure (in the absence of other controls). If the other extreme was considered (ie: one large pre-weighed bag or container) it would be difficult to handle and give rise to substantial ergonomic issues.

The solution adopted was to install a drum lifter with an enclosure around the area above the discharge points (Figure 10.17).



*(Reproduced with permission)*

**Figure 10.17 – Drum Lifter with Discharge Enclosure**

Glove ports were also installed to provide access for the operator to remove the drum lid, open any liner, direct or assist the flow of material, clean the isolator, replace the drum lid and clean any contaminated external parts of the drum inside the isolator.

Before settling on the final design of the isolator a mock-up was made (wood and cardboard) to ensure all ergonomic factors were considered. Factors such as individual operator size, left-handed or right-handed, etc must be considered.

In this case, although the capital cost of the equipment was higher, there was a saving in time for the operator in not having to put on, clean and take off protective clothing and also a saving in the cost of the protective clothing and its cleaning, maintenance and storage.

The key learnings from these two situations include:

- Containment is an effective means of controlling employee exposures

- Implementation of any control strategy that involves the direct involvement of operators needs to take account of individual human factors if they are to be used by all personnel

## **10.8 DIESEL PARTICULATE IN UNDERGROUND COAL MINES**

Diesel engines have been used in the underground mining industry for many years and have been a key factor in the increased productivity of such operations. While the health effects of gaseous emissions were well understood from their initial introduction, little or no attention was paid to the control of the particulate fraction.

This case study details how one industry researched, evaluated and ultimately initiated strategies for the control of diesel particulate in underground coal mines.

As with the control of any contaminant, it is important to have a clear understanding of the physical and chemical properties of the substance plus knowledge as to the potential health effects.

Diesel particulate has been the source of considerable scientific investigation and debate over the past 20 years but it is appropriate to summarise the properties of diesel particulate as follows:

- Generated along with gaseous emissions in the exhaust of every diesel engine
- Small particles (15-130 nm) called spherules
- Agglomerate to form larger particles (<1 µm in diameter)
- Absorb significant quantities of hydrocarbons and other organic compounds
- Have traces of inorganic compounds
- Respirable by humans
- Has a central core of elemental carbon

These properties can be demonstrated schematically or via electron microscopy as per Figures 10.18 & 10.19.

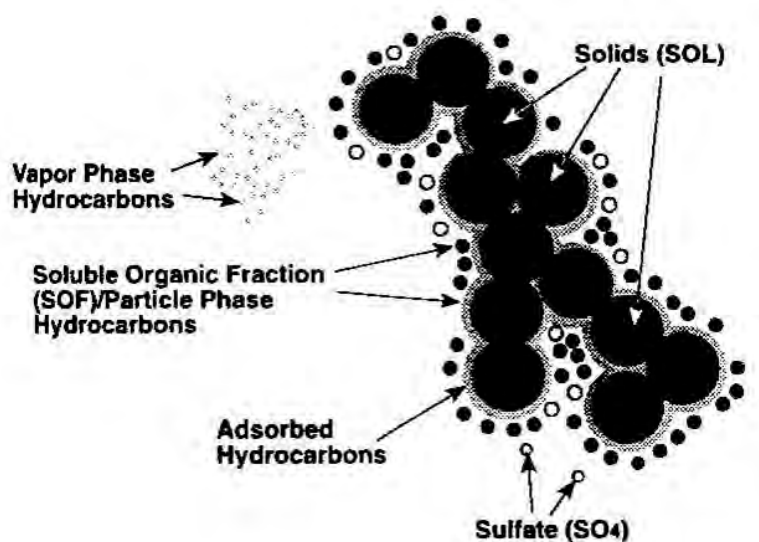

*(Reproduced with permission)*

**Figure 10.18 – Schematic of Diesel Particulate**

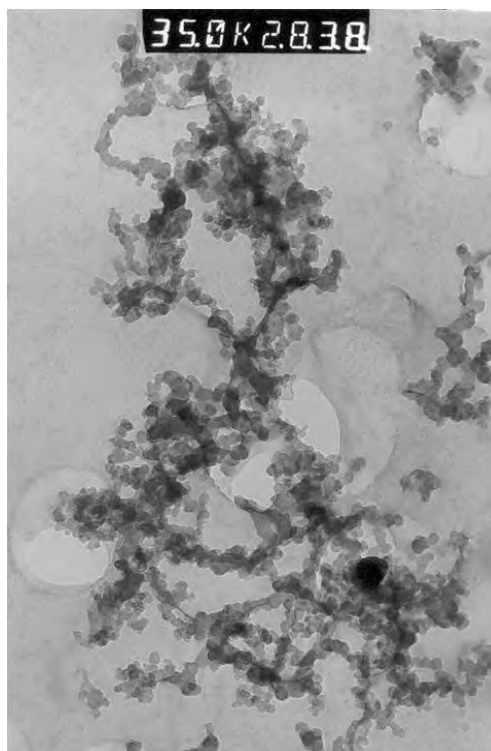

*(Reproduced with permission)*

**Figure 10.19 – Electromicrogram Showing Agglomeration of Small Diesel Particles**

The health effects of diesel particulate are complex and still subject to debate, however the following can be stated:

- Classified as carcinogenic by many authorities throughout the world
- Potency not well defined but significant
- Small particle size of diesel particulate has resulted in it being linked to non malignant health effects similar to PM<sub>2.5</sub>
- Irritant (eyes, nasal and bronchial)

As a result of understanding the properties and health effects of diesel particulate, appropriate control strategies were researched (Davies 2004), developed and implemented. This approach has shown that no single simple solution to control particulate levels in underground coal mines exists and that while a range of control options exist, one or more configurations may be needed to obtain effective control of exposures.

What was also discovered was that individual operations using similar equipment could have significantly different levels of exposure due to differences in ventilation patterns, work practices and most importantly, maintenance.

Notwithstanding the above, the range of potential control options identified includes:

- Low emission diesel fuel
- Ventilation at levels commensurate with the size of the engine. In cases where ventilation is restricted (eg: mines) it may be appropriate to limit the number of diesel engines operating in an area
- Exhaust treatment devices such as catalytic converters, wet scrubber systems, regenerative ceramic filters, disposable exhaust filters, exhaust dilution-dispersal systems
- New generation low emission engines
- Maintenance programmes targeted at minimising exhaust emissions

- Well-sealed and filtered air-conditioned operators' cabins
- Employee education
- Personal protective equipment

While combinations of the above have been found to be effective, one strategy has the potential to deliver higher productivity with reduced employee exposures. The introduction of an emissions-based maintenance programme has been shown by various researchers (McGinn 2000, Davies 2004) to result in improved fleet availability, increased power and thus productivity and lower exhaust emissions.

While this seems apparent, it is based on the premise that individual engines can be tested during maintenance procedures. To do this, raw exhaust measurements for various gases and diesel particulate must be conducted. The measurement of raw exhaust gas levels (carbon dioxide, carbon monoxide and oxides of nitrogen) in diesel engines used in underground coal mines was well established but the measurement of diesel particulate presented complex issues.

One researcher (Davies 2004) developed a mobile laboratory which included a laboratory instrument to measure diesel particulate (Figures 10.20 & 10.21).



(Source: B Davies – reproduced with permission)

**Figure 10.20**



(Source: B Davies – reproduced with permission)

**Figure 10.21**

This proved very effective and in a trial of 66 engines, seven were found to be abnormal. Simple maintenance (Table 10.1) resulted in significant reductions in diesel particulate (measured as elemental carbon).

**Table 10.1 – Examples of the Effect of Maintenance on Raw Exhaust Levels**

Vehicle	Pre Maintenance EC mg/m <sup>3</sup>	Post Maintenance EC mg/m <sup>3</sup>	Maintenance Performed
1	139	46	New fuel pump and cleaned scrubber tank.
2	131	40	New scrubber tank, new injectors, adjusted fuel.
3	159	71	Replaced injectors.
4	102	61	Replaced injectors, cleaned scrubber tank and intake air system.

Once this concept was proved by various researchers, more practical instrumentation has been developed based on laser technology (Figure 10.22) and more recently backpressure on an exposed filter (Figure 10.23).





(Source: AQT Pty Ltd – reproduced with permission)

**Figure 10.22 – Raw Exhaust Diesel Particulate Analyser**



(Source: J Hines – reproduced with permission)

**Figure 10.23 – Portable Raw Exhaust Analyser**

The development of these devices has made the control of diesel particulate at the source (engine) a possibility in underground coal mines.

The key lessons from this case study include:

- No one simple solution exists. Each operation needs to evaluate which control technologies work best for their circumstances.
- Control of diesel particulate requires a major commitment by all involved.
- Emissions-based maintenance programmes offer potential for major gains in emissions and through increased productivity. For this strategy to be effective, this requires the development of a different approach to monitoring the contaminant at its source.
- Attention to detail is necessary to sustain control technologies. Control technologies can degrade quickly in the harsh mining environment thus requiring constant attention to ensure they remain effective.

## 11. REFERENCES

ACGIH® (2009): Threshold limit values for chemical substances and physical agents and biological exposure indices. ACGIH®, 2009

ACGIH® (2007): Industrial Ventilation, A Manual of Recommended Practice 26<sup>th</sup> Edition; ACGIH® 2009

AIHA (2003): The Occupational Environment; its Evaluation, Control and Management. AIHA Press 2003

AIOH (2007): Principles of Occupational Health & Hygiene, Ed. C. Tillman, Australian Institute of Occupational Hygienists, 2007

Ansell (2007): "Do your gloves pass the acid test?" Ansell Chemsafe Brochure, 2007

AS/NZS 1715:2009 Selection Use and Maintenance of Respiratory Protective Devices

AS/NZS 1716:2003 Respiratory Protective Devices

AS/NZS 2161.1:2000, Occupational protective gloves, Part 1: Selection use and maintenance

AS/NZS 2161.10.1:2005 Occupational protective gloves. Part 10 Protective gloves against chemicals and micro-organisms, Parts 1, 2 and 3

ASTM F739-07. Standard Test Method for Permeation of Liquids and Gases through Protective Clothing Materials under Conditions of Continuous Contact

ASTM Standard Guide F1001 – 86 Chemicals – "Selection of Chemicals to Evaluate Protective Clothing Materials

Charney, W. (1991): Hidden toxicities of glutaraldehyde. In: Charney W, Schirmer J, eds. Essentials of modern hospital safety. Chelsea, MI: Lewis Publishers, Inc., pp. 71-81

COSHH Regulations (2002): The control of substances hazardous to health regulations 2002 (as amended)

Davies, B. (2004): The Control of Diesel Particulates in Underground Coal Mines. Doctoral Thesis, Victoria University, Australia 2004

EN 166:2002. Personal eye protection, Specifications

EN 374-1:2003. Protective gloves against chemicals and micro-organisms. Terminology and performance requirements

EN 374-3:2003. Protective gloves against chemicals and micro-organisms. Determination of resistance to permeation by chemicals

EN 420:2003. Protective gloves, General requirements and test methods

EN 529:2005, Respiratory protective devices – Recommendations for selection, use, care and maintenance – Guidance document

European Chemical Agency - Guidance for intermediates, February 2008

Gardiner, K. & Harrington, M.J. (2005): Occupational Hygiene, 3<sup>rd</sup> Edition. Blackwell Publishing 2005

Goede, Henk; Tielemans, Erik; van der Schaaf, Doeke; Schinkel Jody; le Feber, Maaïke; van Hemmen, Joop, J. (2006): Development of an Exposure Control Efficiency Library (ECEL). Journal of Epidemiology, 17(6)

Hirst N., Brocklebank M., Ryder M. 2002, Containment Systems – A Design Guide. ISBN 07-7506-7612-4

HSE (2004/2005) COSHH: A brief guide to the Regulations. INDG136(rev 3) 04/05. Health and Safety Executive

HSE (2008) COSHH Essentials: Easy steps to control chemicals. Health and Safety Executive 2008 [www.coshh-essentials.org.uk](http://www.coshh-essentials.org.uk) (accessed August 2008)

HSE (2008): Controlling Airborne Contaminants at Work. Health & Safety Executive, HSG 258, 2008

HSE: HSG53 - Respiratory protective equipment at work – a practical guide, 2005.

HSE (2004) HSG54 – Maintenance, examination and testing of local exhaust ventilation, 2004

IARC (2008): Monographs on the Evaluation of Carcinogenic Risks to Humans <http://monographs.iarc.fr> (accessed August 2008)

ILO (2008) ILO Chemical Control Toolkit, International Labour Organisation. [http://www.ilo.org/public/english/protection/safework/ctrl\\_banding/toolkit/icct/index.htm](http://www.ilo.org/public/english/protection/safework/ctrl_banding/toolkit/icct/index.htm) (accessed August 2008)

ISO 13688:1998. Protective clothing – General requirements. ISO 1998

ISO 16602:2007. Protective clothing for protection against chemicals – Classification, labelling and performance requirements. ISO 2007

ISO 6529:2001. Protective clothing – Protection against chemicals - Determination of resistance of protective clothing materials to permeation by liquids and gases. ISO 2001

JIS T8150:2006 – Guidance for selection, use and maintenance of respiratory protective devices

KS P1101:2004 - Guidance for selection, use and maintenance of respiratory protective devices

McGinn, S.: The relationship between diesel engine maintenance and exhaust emissions – Final Report: DEEP Project

Nauman B.D., Sargent E.V., Starkman B.S., Fraser W. J., Becker G.T., and Kirk G.D., 1996, Performance-based Exposure Control Limits for Pharmaceutical Active Ingredients, Am. Ind. Hyg. Assoc. J., 57, 33-42

NIOSH (2004): NIOSH respirator selection logic. Cincinnati, OH: US Department of Health and Human Services, Public Health Service, Centers for Disease Control, National Institute for Occupational Safety and Health, DHHS (NIOSH). Publication No. 2005-100

OHSAS 18001:2007: Occupational Health & Safety Management System – Requirements

Opel, R., Kalberlah, F., Evans, P.G. & Van Hemmem, J.J. (2003): A Toolkit for Dermal Risk Assessment and Management: An Overview. Ann. Occup. Hyg. Vol.47, No.8, 629-640, 2003

OSHA Regulations (Standards - 29 CFR) 1910.134 Respiratory Protection

OSHA Regulations (Standards 29 CFR 1910.120 Hazardous waste operations and emergency response

OSHA Regulations (Standards 29 CFR 1910.132 General requirements

OSHA Regulations (Standards 29 CFR 1910.133 Eye and Face Protection

OSHA Regulations (Standards 29 CFR 1910.138 Hand Protection

Popendorf, W. (2006): Industrial Hygiene Control of Airborne Chemical Hazards. Taylor & Francis, 2006

Regulation (EC) No 1907/2006: REACH Regulation. European Community 2006 [www.ec.europa.eu](http://www.ec.europa.eu) accessed on 20 July 2008

SANS 10220:2003: The selection, use and maintenance of respiratory protective equipment.

Zalk, David M. and Nelson, Deborah Imel (2008) 'History and Evolution of Control Banding: A Review', Journal of Occupational and Environmental Hygiene, 5:5, 330 — 346.

<http://oeh.informaworld.com/soeh/content~content=a791578562~db=all~order=page>

Accessed 7 Sept 2008