

# **Next Generation Sampler for Personal Monitoring**

Dr John H Dennis, University of Calgary

Dr Mahmoud Abdel-Salam, University of Alexandria

Dr Ayman Arfaj, Saudi Aramco

# Successful innovations

- Easier
- Cheaper
- Better

# Traditional aerosol sampling train with double diaphragm pump

- Noise
- Bulk
- Challenging to wear
- Battery life
- Aerosol Vs gas/vapour
- Expense



# All brands have similar design limitations ...



## ...design limitations revolve around filters

# Why not use a lower resistance filter?



3M Filtrete electrostatic media

5.0kV X350

50µm 000002

If low resistance filters proved suitable in OHS for Collection & Analysis

Then there use offers potential innovation in sampling system

Use a fan to pull air



routinely rely on low resistance filters



OHS confident 3M Filtrete collects aerosol effectively

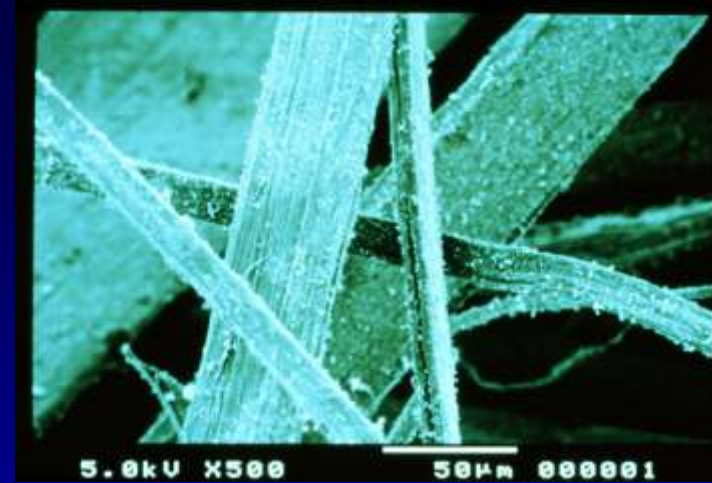

Mahmoud has shown it also allows analysis of collected aerosol



Ayman has shown 3M charcoal filters allow analysis of collected vapours



# Advantages of existing low resistance media

- Low resistance
- High loading
- Stable
- Collect industrial pollutants of interest
- Filtrete filter and charcoal filter in series allows concurrent sampling of aerosols & vapours using same sampler



# Development of Sampling system

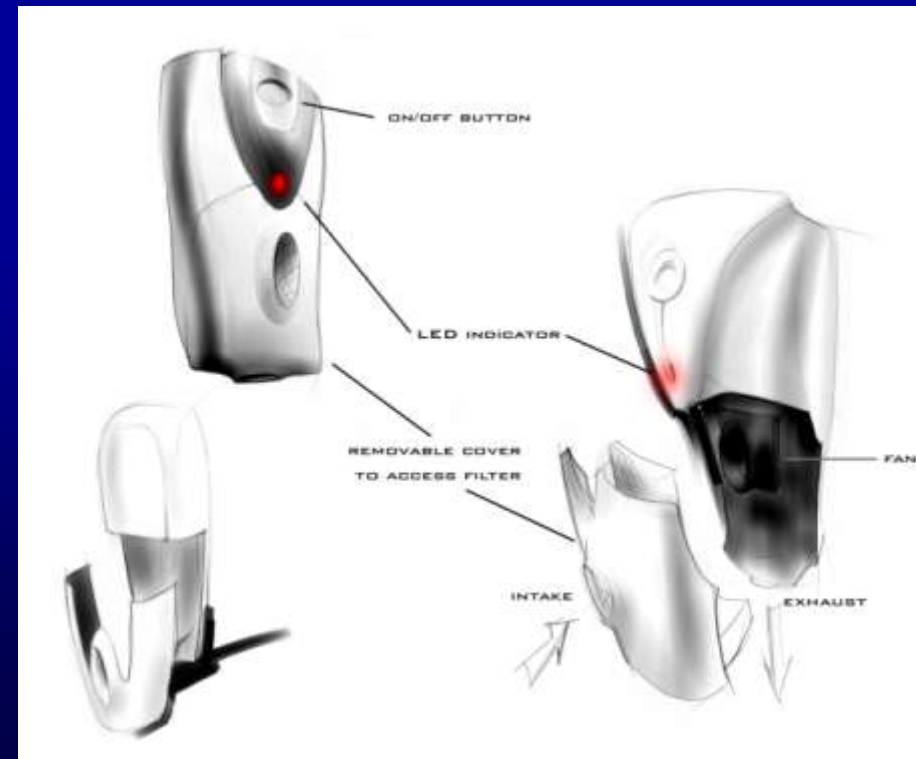
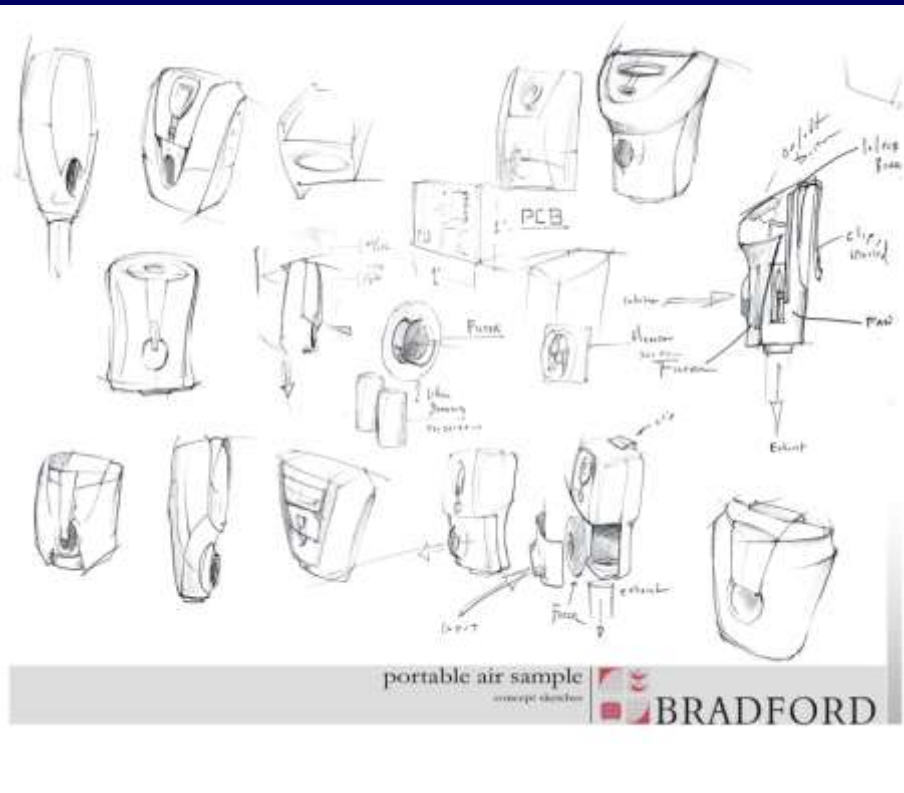



2003



2005



2008

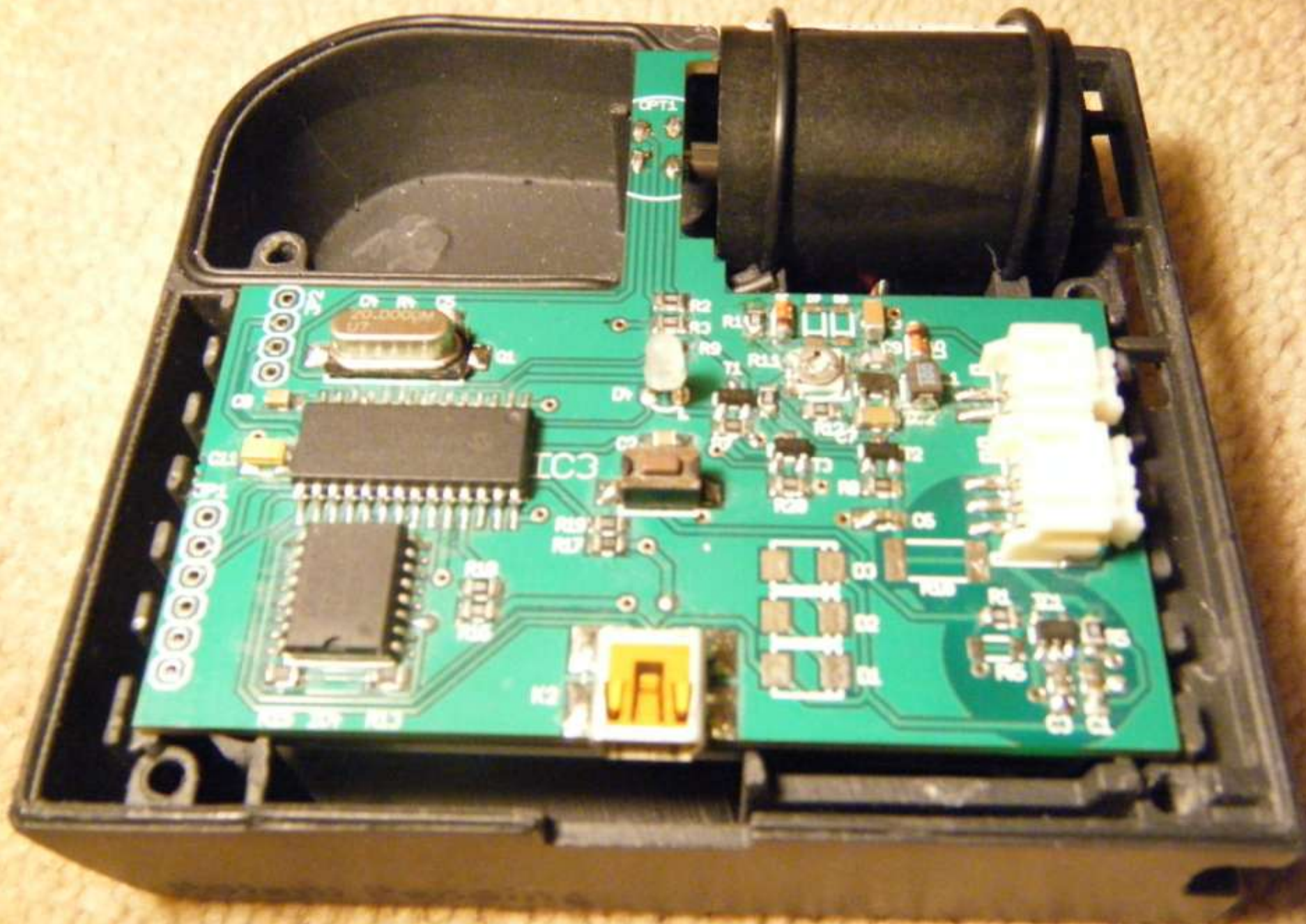

## Final design pending

- Input on manufacture of small sealed charcoal filters
- Allow efficient insertion of 3 filter combination
- Simple electronic controls
- Business development plan

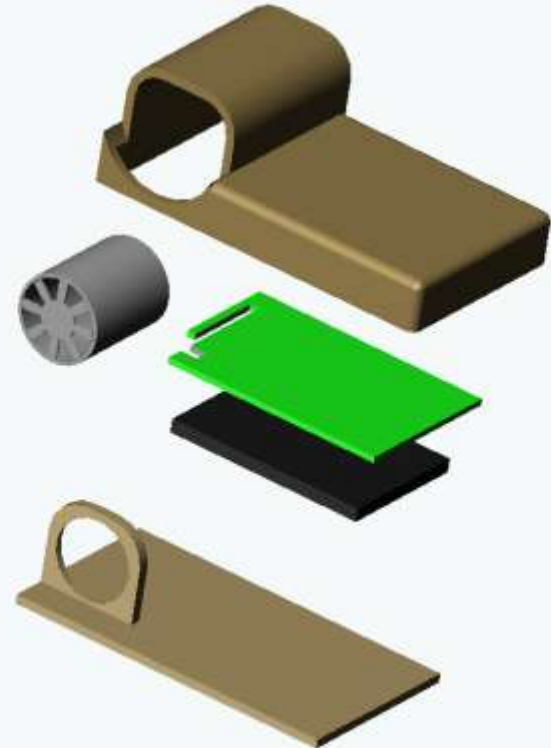
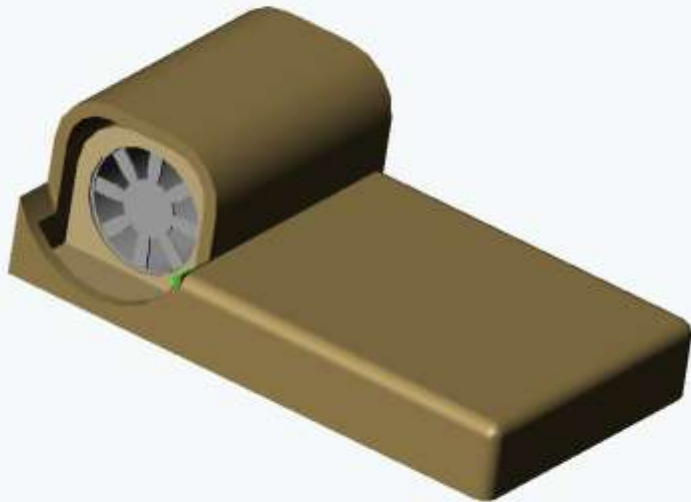

## Advantages

- smaller
- lighter
- Near silent
- Long battery life
- 3M Filters offer as good or better loading, sensitivity & stability

*Less invasive = better quality sample?*

## Disadvantages

- New application for filters
- OHS naturally conservative
- Lab analysis procedures
- Product development demanding on time & resources
- Not applicable to asbestos

# Sampler development

Original idea in 2001

Patents filed

PhD research

- 3M Filtrete

- 3M Charcoal

UofB Business Innovation

Next Generation Sampler is 95% ready

Currently being transitioned from development to production and marketing

1% inspiration & 99% perspiration

Thomas Alva Edison

*'I never did anything worth doing by accident, nor did any of my inventions come by accident. They came by work'*

Sorry sampler has taken so long

Much appreciation to students

Many thanks

[jhdennis@ucalgary.ca](mailto:jhdennis@ucalgary.ca)